

**FANS  
FOR RAILWAY TECHNOLOGY**



**Rosenberg Ventilatoren GmbH**

Maybachstr. 1/9  
D-74653 Künzelsau-Gaisbach  
Fon +49 (0)7940 / 142-0  
Fax +49 (0)7940 / 142-125

[www.rosenberg-gmbh.com](http://www.rosenberg-gmbh.com)  
[info@rosenberg-gmbh.com](mailto:info@rosenberg-gmbh.com)

# Your powerful business partner

... in the matter of railway technology



Air is our element – moving it **intelligently and efficiently** is our passion. Since 1981 we have been developing and producing adjustable external rotor motors, fans and air handling units.

**German Engineering skill** is the basis of our development work and drives our innovation. As a worldwide company we are represented where our customers need us. With production sites and sales offices in more than 45 countries **we are present worldwide** – a strong and reliable partner always within reach of our customers.

Numerous manufactures and suppliers of the railway industry trust in our fans. **Permanent and logical products as well as quality improvements come first with us.** The continuous exchange of information between customers and factory engineers enables us to develop flexible and reliable system solutions quickly.

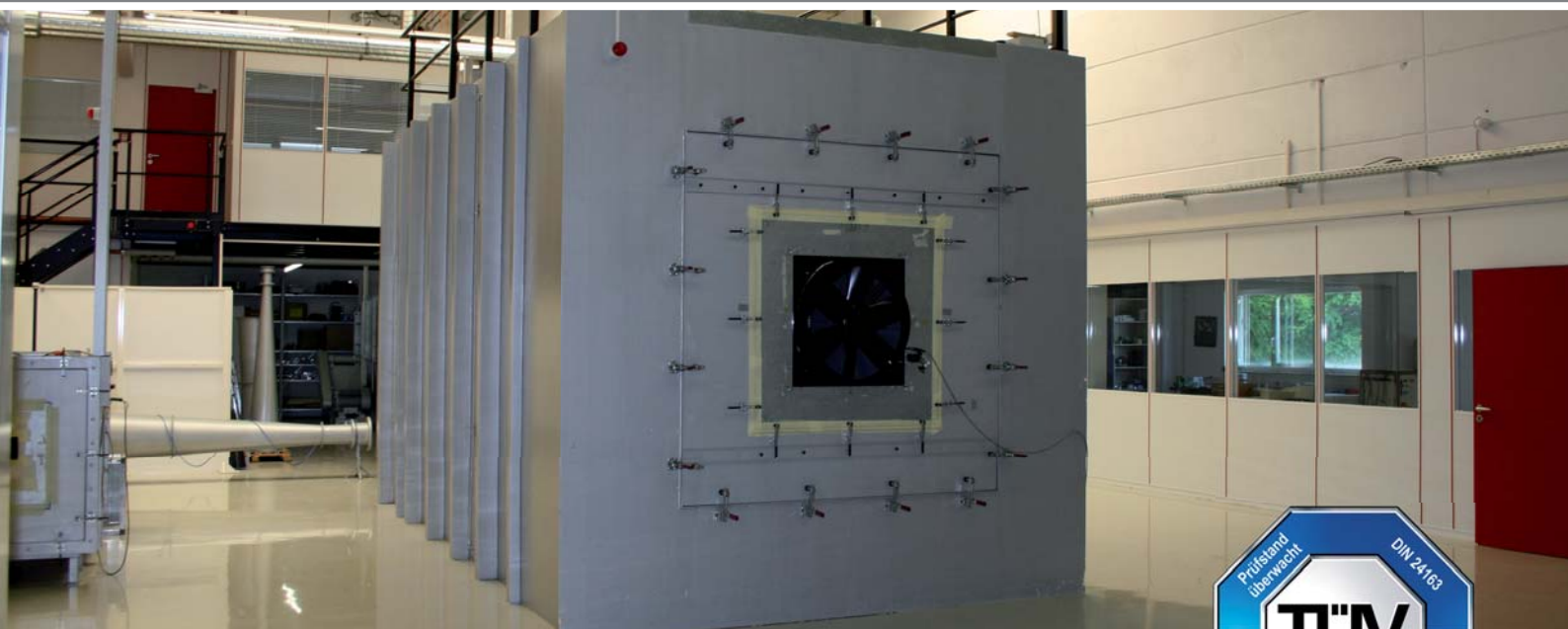

**Customer specific developments enable a smooth operation also at:**

- voltage peaks
- high shock stress
- vibrations
- varying weather conditions and thermal stresses

**... and offer flexible solutions for:**

- optimal airflow
- various operation voltages (at 50/60 Hz)
- maximum efficiencies at variable speeds
- minimum maintenance

## Our versatily business activities



### Air conditioning of the driver's cab

The workplace of the train driver places high technical demands on heating, ventilation and air-conditioning. Whether on-roof systems, integrated roof systems or under floor installations – for the required air movement our free-running-impellers from the DKHR/M series (EC-variant GKHR/M) are ideally suited. Also centrifugal fans of the type ERA, axial fans from the series AKF/AKS as well as fans from the ECOFIT series REE and VRE are eminently suitable for this application.



### Cooling of components of the propulsion and braking system

The traction system of a rail vehicle consists of different elements like tractions motors or traction inverters. To avoid harmful overheating the heat has to be dissipated. The same is true for components of the braking system of trains. Free-running impellers from the DKHR/M series (EC-variant GKHR/M), centrifugal fans of the type ERA/DRA, as well as centrifugal fans from the ECOFIT series GDF are best suitable for this field of application.

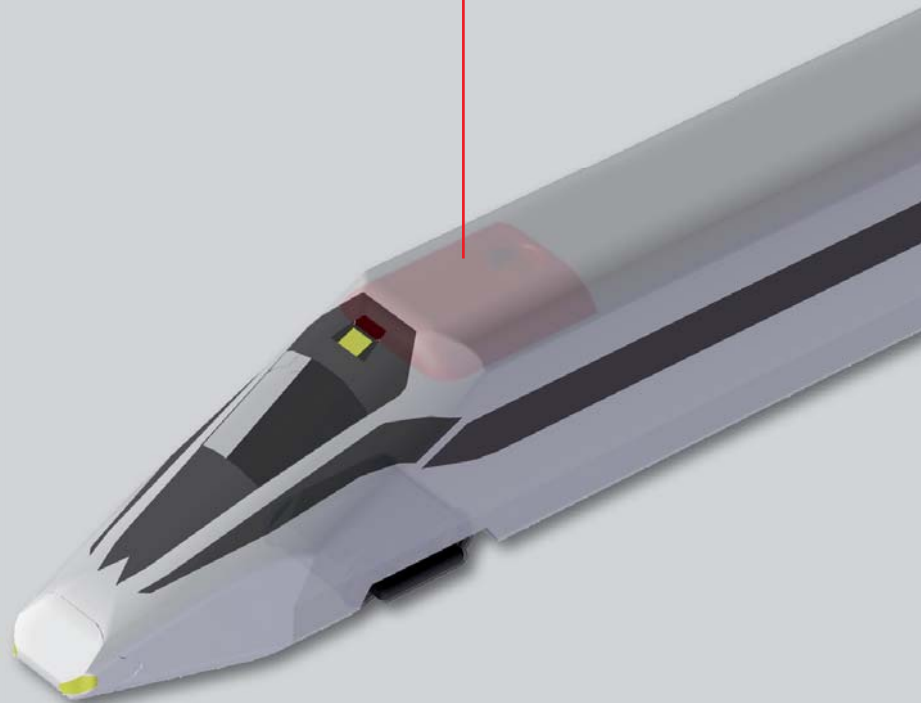



### Air conditioning of the passenger cabin

Comfort for passengers is a top priority in railway technology. Fans of the Rosenberg group are the right choice for a pleasant climate in the cars. They reach the required operating point within integrated system solutions reliably at minimum space requirements. Such characteristics have for example our free-running impellers from the DKHR/M (EC-variant GKHR/M), centrifugal fans of the type DRA, centrifugal fans from the ECOFIT series GDF, as well as AKF/AKS axial fans.

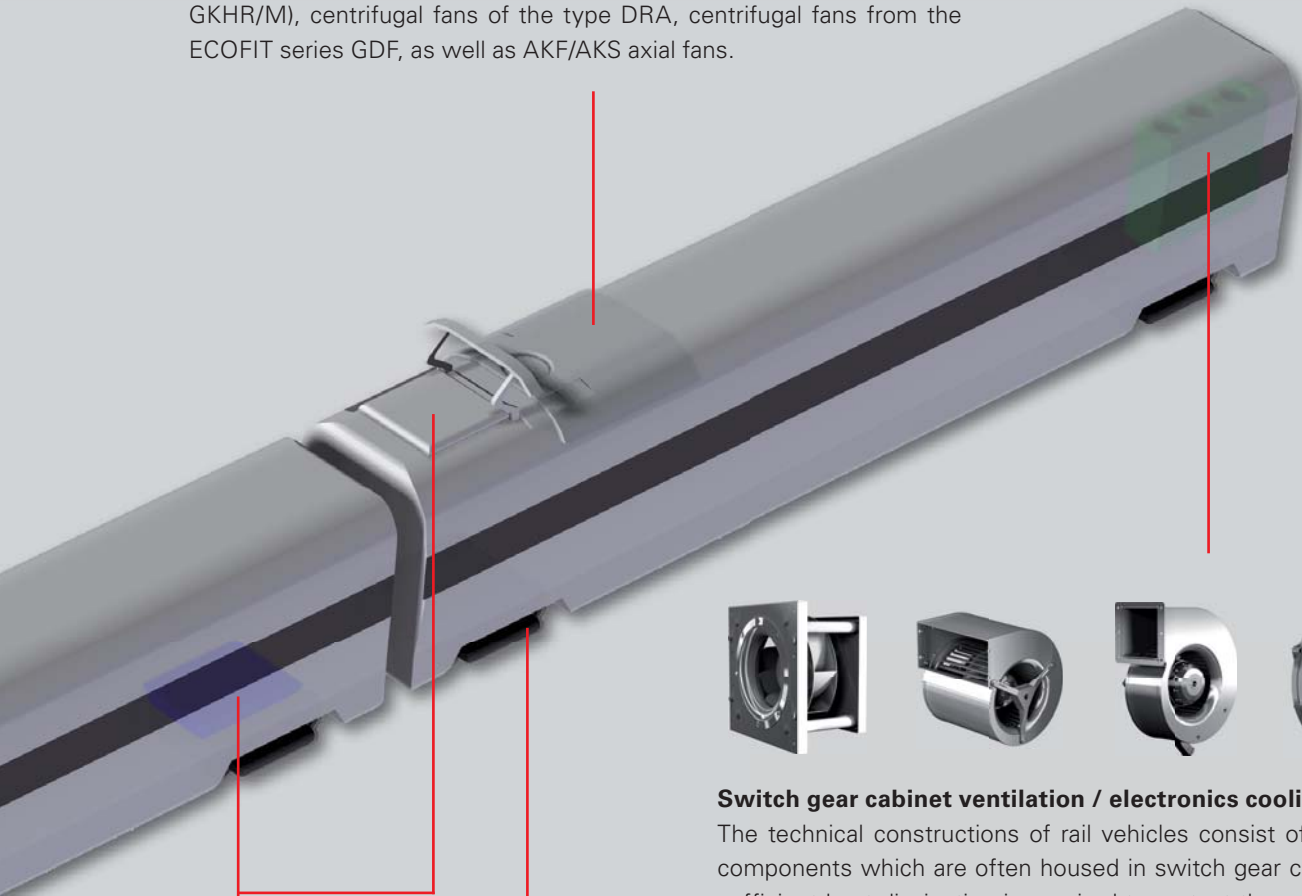

### Switch gear cabinet ventilation / electronics cooling

The technical constructions of rail vehicles consist of many electronic components which are often housed in switch gear cabinets. Here too sufficient heat dissipation is required to protect the sensitive electronic components. Our free-running impellers from the DKHR/M series (EC variant GKHR/M), centrifugal fans of the type ERA or fans from the ECOFIT series REE and GDF were especially designed for this application.



### Cooling of components of the onboard power system

High precision power supply within the onboard power system of rail vehicles is state-of-the-art today. Comparable with the propulsion system of trains, here system components which have to be cooled are used as well. For these cooling applications, our free-running impellers from the DKHR/M series (EC variant GKHR/M), centrifugal fans of the type ERA/DRA, as well as fans from the ECOFIT series REE and GDF are used.

# Product choice for railway applications

## Fans for highest standards



### Free running impellers Type: DKHM / DKHR

- with AC external rotor motor
- impeller with backward curved blades
- single impeller (DKHR) or as module ready-to-install (DKHM)
- because of its space saving design ideally suited for small installation space
- air volumes up to 15.000 m<sup>3</sup>/h (8.800 cfm)
- total pressure increase up to 1.400 Pa (5.6 "WG)

### Fields of application:

Air conditioning of the passenger cabin, driver's cab, switch gear cabinet ventilation, electronics cooling, cooling of components



### Free running impellers Type: GKHM / GKHR

- with EC motor
- impeller with backward curved blades
- single impeller (GKHR) or as module ready-to-install (GKHM)
- because of its space saving design ideally suited for small installation space
- air volumes up to 15.000 m<sup>3</sup>/h (8.800 cfm)
- total pressure increase up to 1.400 Pa (5.6 "WG)

### Fields of application:

Air conditioning of the passenger cabin, driver's cab, switch gear cabinet ventilation, electronics cooling, cooling of components



### Centrifugal fans Type: ERA

- single inlet centrifugal fan with forward curved centrifugal impellers
- variable mounting positions possible
- air volumes up to 8.000 m<sup>3</sup>/h (4.700 cfm)
- total pressure increase up to 1.000 Pa (4.0" WG)

### Fields of application:

Air conditioning of the driver's cab, electronics cooling, cooling of components (braking system, motors)



**Centrifugal fans Type: DRA**

- double inlet centrifugal fan with forward curved centrifugal impeller
- variable mounting positions possible
- air volumes up to 15.000 m<sup>3</sup>/h (8,800 cfm)
- total pressure increase up to 1.100 Pa (4.4 "WG)

**Fields of application:**

Air conditioning of the passenger cabin, cooling of components, transformer cooling



**Axial fans Type: AKF / AKS**

- 3 blade settings for achieving the required operation point
- because of its flat design ideally suited for small installation space
- air volumes up to 20.000 m<sup>3</sup>/h (11,700 cfm)
- total pressure increase up to 200 Pa (0.8 "WG)

**Fields of application:**

Air conditioning of the passenger cabin, air conditioning of the driver's cab (for example capacitor cooling)



**Axial fans (ECOFIT + ETRI) Type: 200 DW**

- reliable operation also at high air humidity
- excellent isolation by means of encapsulated stator and electronic with resin
- extremely compact design (200 mm impeller diameter)
- air volumes up to 1.000 m<sup>3</sup>/h (580 cfm)
- total pressure increase up to 950 Pa (3.8 "WG)

**Fields of application:**

Electronics cooling

# Product choice for railway applications

## Fans for highest standards



### Free running impellers (ECOFIT) Type: REE

- impeller with backward curved blades
- because of its space saving design ideally suited for small installation space
- easy to mount / very easy to maintain
- air volumes up to 1.700 m<sup>3</sup>/h (1,000 cfm)
- total pressure increase up to 775 Pa (3.1 ''WG)

### Fields of application:

Air conditioning of the driver's cab, electronics cooling



### Axial fans (ECOFIT) Type: VRE

- because of its flat design ideally suited for small installation space
- air volumes up to 3.300 m<sup>3</sup>/h (1,900 cfm)
- total pressure increase up to 300 Pa (1.2 ''WG)

### Fields of application:

Air conditioning of the driver's cab



### Centrifugal fans (ECOFIT) Type: GDF

- double inlet centrifugal fan with forward curved centrifugal impeller
- variable mounting positions possible
- air volumes up to 1.475 m<sup>3</sup>/h (870 cfm)
- total pressure increase up to 650 Pa (2.6 ''WG)

### Fields of application:

Air conditioning of the passenger cabin, electronics cooling, cooling of components



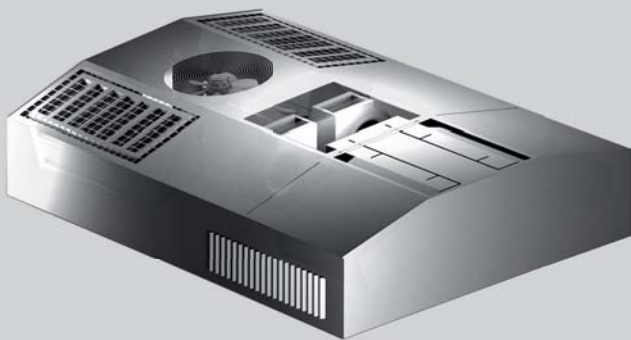

**Application: Railway roof air handling unit**

The Rosenberg group supplies fans for railway technology since 1981. Very often, these fans are integrated in air handling units, which are installed directly in the roof of the trains.

Because of the compact dimensions of the units, which are connected with the supply air channel of the roof, the fans have to be designed space-saving and still powerful. At the same time maintenance openings have to be considered, to guarantee an easy access for maintenance.

**In cooperation with our customers, we work out the ideal solution for the respective requirements.**

# References

regional railways / High-speed trains



## Regional trains, city trains, metros and trams

- Bombardier/Alstom: **TER2N**
- Stadler: **Flirt, GTW**
- Siemens/Bombardier: **ET 425/426**
- Alstom: **Citadis, Coradia LIREX**
- Bombardier: **TALENT 2, SPACIUM, FLEXITY, VT 612**
- Siemens: **Desiro (Classic, MainLine, Double Deck), Combino**



## Long distance traffic / High-speed trains

- Talgo: **Trenhotel**
- AnsaldoBreda: **V250, ETR500**
- Bombardier: **CRH1, Voyager, ZEFIRO 250**
- Siemens: **CRH3, Velaro-Rus, Velaro-D, Railjet**
- Alstom: **New Pendolino, Pendolino, CRH5, AGV, RGV**
- Alstom/Bombardier/ **ICE-T**
- Siemens:

Your sales representative: