

nuvohla

Breathe Better



Catalogue
Air and surfaces purification

INDEX



TECHNOLOGY 4

Introduction
Effectiveness



APPLICATIONS 8



PRODUCTS 12

NuvoHla Room
NuvoHla Lift



GALLERY 22

Introduction



Airtècnics has developed a disruptive and innovative patented technology that responds to the current and future global need for environmental hygiene.

The new range of Nuvohla purifying Open Air Factor OAF emulator devices efficiently generate and expand neutral hydroxyl radicals (OH·) to inactivate up to 99.99% of pathogens and pollutants in the air and on surfaces. This technology is called **Active** because it expands its properties throughout the environment and not only acts on the air passing through the device.

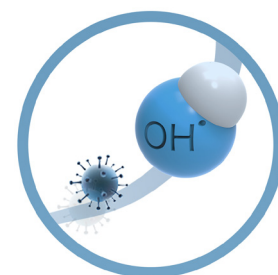

It satisfies the exposure limits for chemical agents adopted by the National Institute for Health and Safety (INSS). These parameters include ozone emissions (<0.05ppm) and hydrogen peroxide emissions (<1ppm or <0.1 mg/m3). Open Air Factor OAF emulator technology has been tested in independent laboratories and more than complies with both limits.



The oxidising agent OH·, qualified as a “natural detergent” due to its capacity to clean the atmosphere, neutralises (mineralize) more than 2,500 different compounds such as carbon dioxide and methane, the main causes of the greenhouse effect. Hydroxyl radicals are produced in nature as an Open Air Factor by the Photocatalytic combination of the oxygen, sun’s ultraviolet rays with ozone together the humidity in the atmosphere, and also by reactions caused by the ozone present in the environment on plant oils (terpenes)

By means of Advanced Oxidation Processes (AOP) produced by hydroxyl radicals (OH·) it is achieved:

- Inactivate up to 99.99% of pathogenic microorganisms (viruses and bacteria).
- Improve air quality by reducing Volatile Organic Compounds (VOCs) and suspended particles (PM).
- Eliminate odours.

Oxidising Agent	Electrochemical Oxidation Potential (EOP)	EOP relative to Chlorine
Fluor	3,06	2,25
Hydroxil Radical	2,80	2,05
Ozone	2,08	1,52
Hydrogen Peroxide	1,78	1,30
Chlorine	1,36	1,00

Source: University of South California

Its great oxidising power is complemented by the chain effect it produces, and releases more Reactive Oxygen Species (ROS), thus generating a wave of purifying and disinfecting agents that spreads through the atmosphere.

Introduction

Harmful Agents Inhibited by Open Air Factor "OAF" emulator Technology



Odours



Chemicals

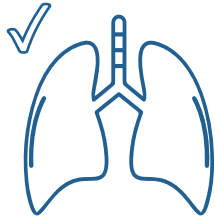

Asthma and allergens



Pollen and
dust mite

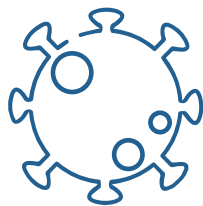

Viruses

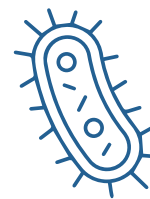

Bacteria



PM particles



Fungi and spores

Efectiveness

The purifying and disinfecting power of Open Air Factor OAF emulator technology has been tested in several studies on viruses, bacteria, volatile organic compounds, odours and other suspended particles.

Viruses

Viruses are the most transmissible pathogen in the environment due to their microscopic size and high volatility. In all surface tests that have been conducted, hydroxyl radicals have inactivated 92-99% of enveloped and non-enveloped viruses in both wet and dry environments. In air, the results are expected to be better because the hydroxyl radical can affect the pathogen across its entire surface.

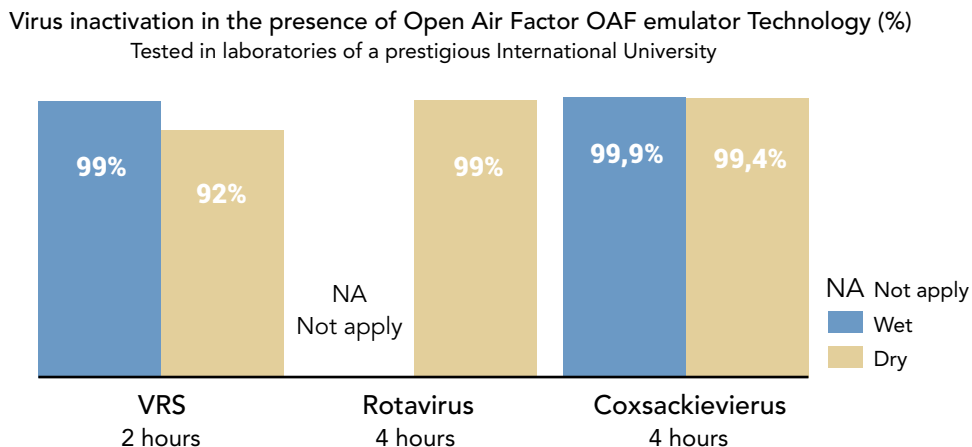

The efficacy on untested viruses will be similar to that of tested viruses because their morphological structure is similar. Therefore, the results for Covid-19, whose morphological structure is similar to that of the Respiratory Syncytial Virus (RSV), would show an efficacy between 92 and 99%.

Bacteria

In the case of bacteria, the oxidation from OAF reacts with fatty acid chains and proteins, modifying their morphological structure and potentially affecting their genetic information.

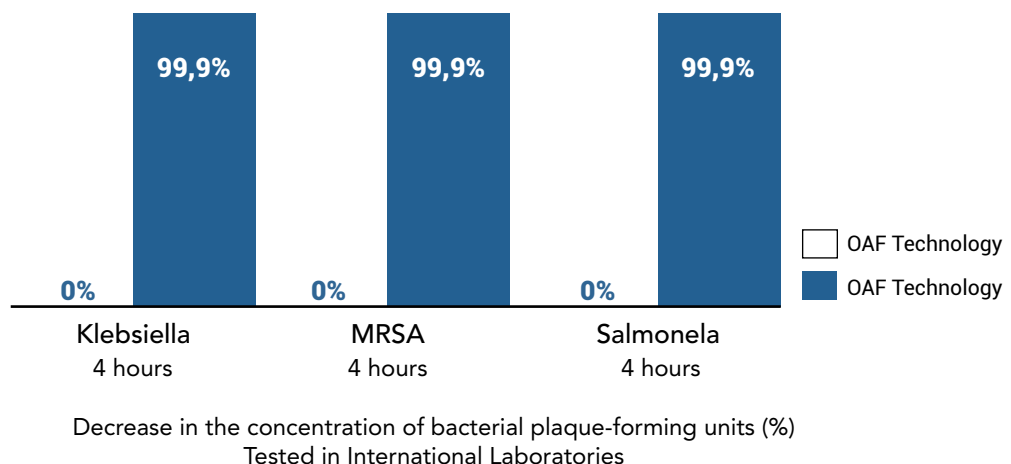

In addition to these tests, other tests were carried out on bacteria bacillus subtilis, Staphylococcus Aureus, Pseudomonas Aeruginosa and Escherichia Coli in which a similar efficacy was demonstrated. Several field tests have even been carried out in Hospitals and Schools showing that it inactivate and prevents the appearance of mould caused by excess humidity.

Efectiveness

Air quality

Air quality is mainly determined by the concentration of Volatile Organic Compounds (VOCs) and particle matter (PM). In one hand, VOCs are carbon-based chemical compounds that may contain fluorine, chlorine, bromine or sulphur, all of which are harmful to health. PM, on the other hand, can cause serious damage to the respiratory system.

OAF mineralise VOCs and transform them into compounds that are entirely harmless to humans and nature. PM are also affected by these radicals by converting them into heavier compounds that fall to the ground, thus reducing air pollution.

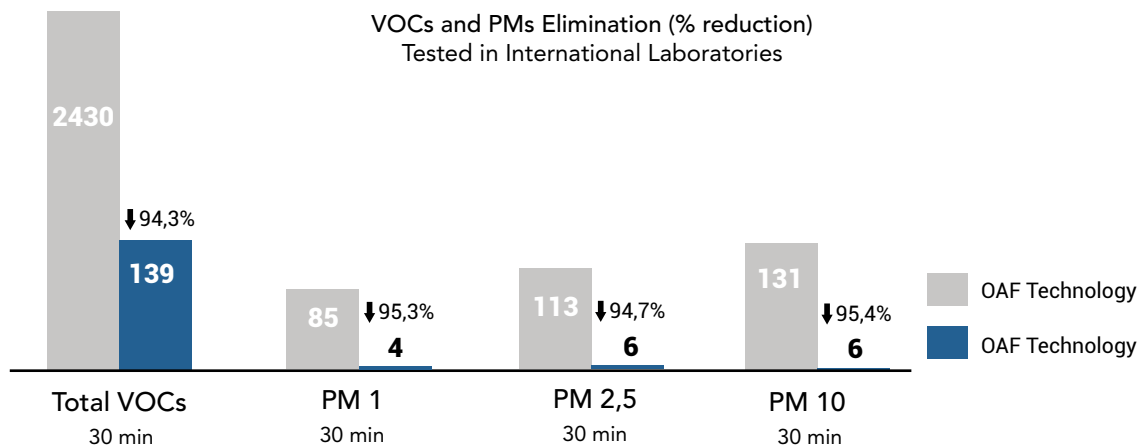

Odours

A pleasant environment must smell good or be odourless. Thanks to the degradation produced by OAF Technology large part of these odors are eliminated within a few hours of exposure to Nuvohla.

The results obtained against the 3 main indicators for odor removal guarantee that the oxidizing technology is perfect for deodorization.

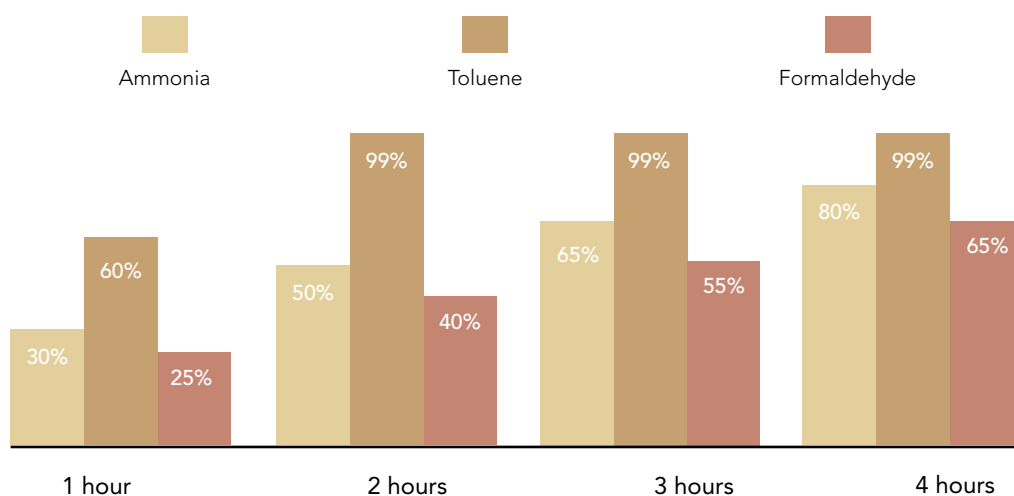

Deodorisation test during the first 4 hours of exposure to OAF Technology (%)
Tested in International Laboratories

APPLICATIONS



Healthcare Sector



Laboratories

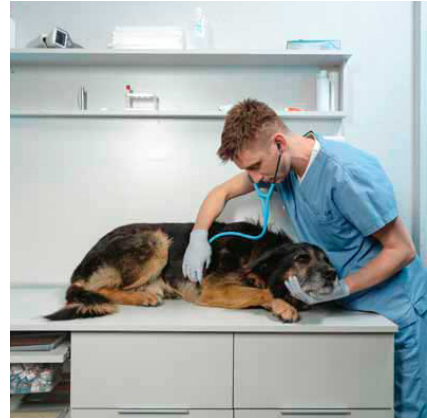

Veterinary Clinics



Educational centers
and nurseries

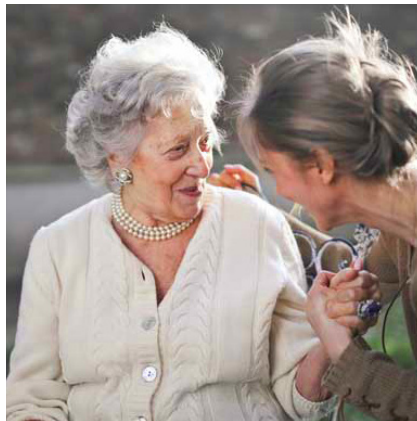

Nursing homes



Private sector



Shops



Home



Hotels and tourism



Sport centers



Public restrooms and locker rooms



Supermarkets



Lifts



Transport



Bars and restaurants



Cinemas and theaters



Clubs and nightlife



Food industry

PRODUCTS

Nuvohla Room

Nuvohla Lift



nuvohla
Room



nuvohla
Lift

purify your home

Nuvohla Room

Nuvohla Room device cleans and purifies the indoor air and surfaces in your home, providing a healthy and safe environment for your family.



Technical Features

- Inhibits allergens, mold, odors and volatile organic compounds (VOCs) and suspended particles (PMs) until 99.9%, according to studies carried out at universities and independent laboratories.

- Does not use filters for air purification.

- Touch control panel integrated in the side of the equipment with power and night mode buttons, as well as cartridge change and alarm warning indicators.

- Works with cartridges filled with a hydrogen peroxide solution. Each consumable has a durability of 3 months.

- Very low electrical consumption. It only requires a 12VDC power supply.

- Low noise level.

- The night mode turns off the LED indicator and reduces the noise of the device, making it easier to sleep.



Range

150 m³ (50 m² x 3 m)



Consumption (1h)

4,2 Wh



Noise level

39 dBA



Weight

0,5 Kg



Color

RAL 9016



Automatic Operation

Automatically purifies contaminants in the air and on surfaces



Night Mode

Quiet operation. Low brightness for a comfortable sleep



Cartridge Alarm

Lets you know in advance the time to replace the cartridge



Alert

Notifies in case of empty cartridge or when incorrect insertion causes a stop in function

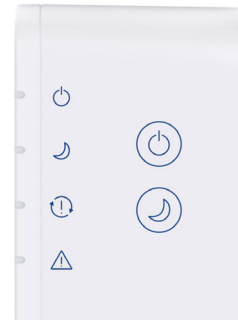
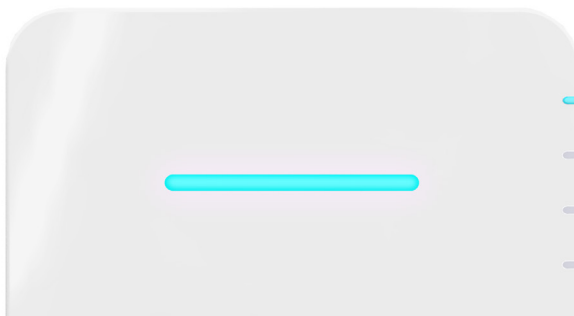

Real-time LED indicator of the state of air and surface contamination in the operating area. Depending on the amount of Volatile Organic Compounds the air quality may be:

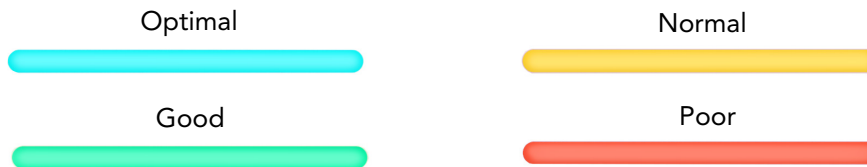

Dimensions

The device has a nice compact design with overall dimensions of 212 x 147 x 100 (mm). It is ideal for disinfecting small spaces and its timeless design and low volume and weight make it easily transportable between different rooms and perfectly integrated into its surroundings.

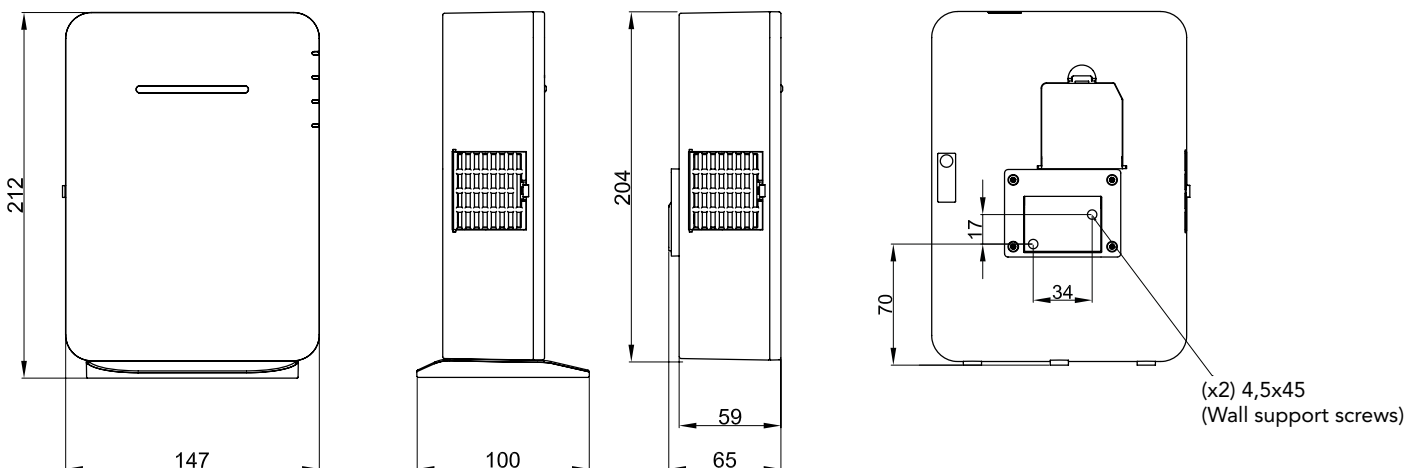

Maintenance

It is advisable to maintain the filter when replacing the consumable by washing it with water and replacing it so that it traps any particles that may damage the fan.



Nuvohla Room works with interchangeable cartridges, which must be replaced every 3 months by accessing from the cartridge service door behind the equipment.

Cartridge of hydrogen peroxide 17,5%.

Accessories

Nuvohla Room has a standing foot support or can be anchored to the wall.

For wall installation, it has a two-piece set. The first, made of plastic, supports the equipment and enters inside the second piece of metal sheet, which acts as a hanger and is fixed to the wall.

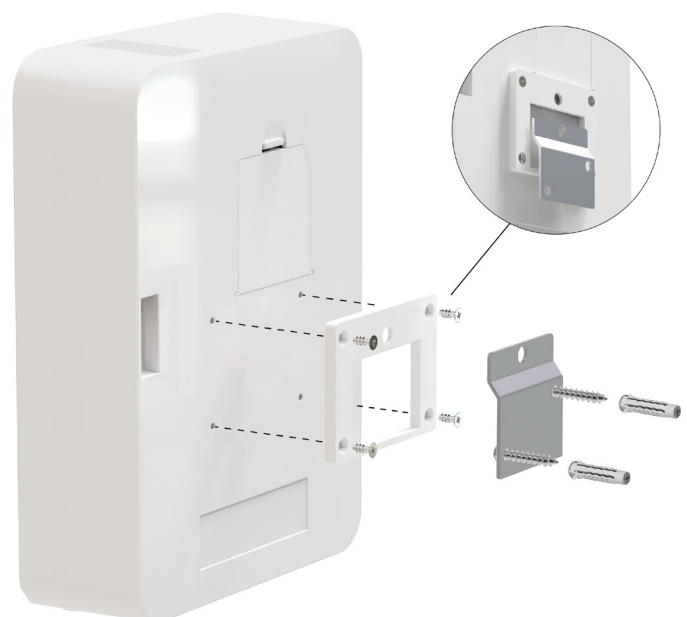

quality air in your **co**mpany

Nuvohla Lift

The Nuvohla Lift device cleans and purifies indoor air and surfaces, contributing to the sanitization and deodorization of the environment in your business.



Technical Features

- Inhibits allergens, mold, odors and volatile organic compounds (VOCs) and suspended particles (PMs) until 99.9%, according to studies carried out at universities and independent laboratories.
- Works with cartridges filled with a hydrogen peroxide solution. Each consumable has a durability of 3 months.
- Does not use filters for air purification.
- Uninterrupted operation 24h/7 days.
- Very low electrical consumption. It only requires a 12VDC power supply.
- It has an alarm signal to connect to the elevator regulator equipment.
- Possibility of wall or ceiling installation.
- Low noise level.



Consumption (1h)

4,2 Wh



Noise level

39 dBA



Weight

0,5 Kg



Color

RAL 9016

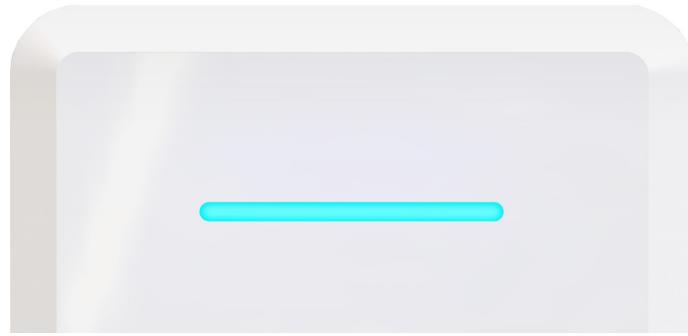

The front LED can indicate two states of the device depending on its colour. It will light up blue continuously when the unit is in operation, and will flash red when the disinfectant cartridge is empty.



Dimensions

The unit has a nice compact design with overall dimensions of 204 x 147 x 65 (mm). It is ideal for disinfecting small spaces, specially lifts. Its timeless design and its low volume and weight make it perfectly integrated with its surroundings.

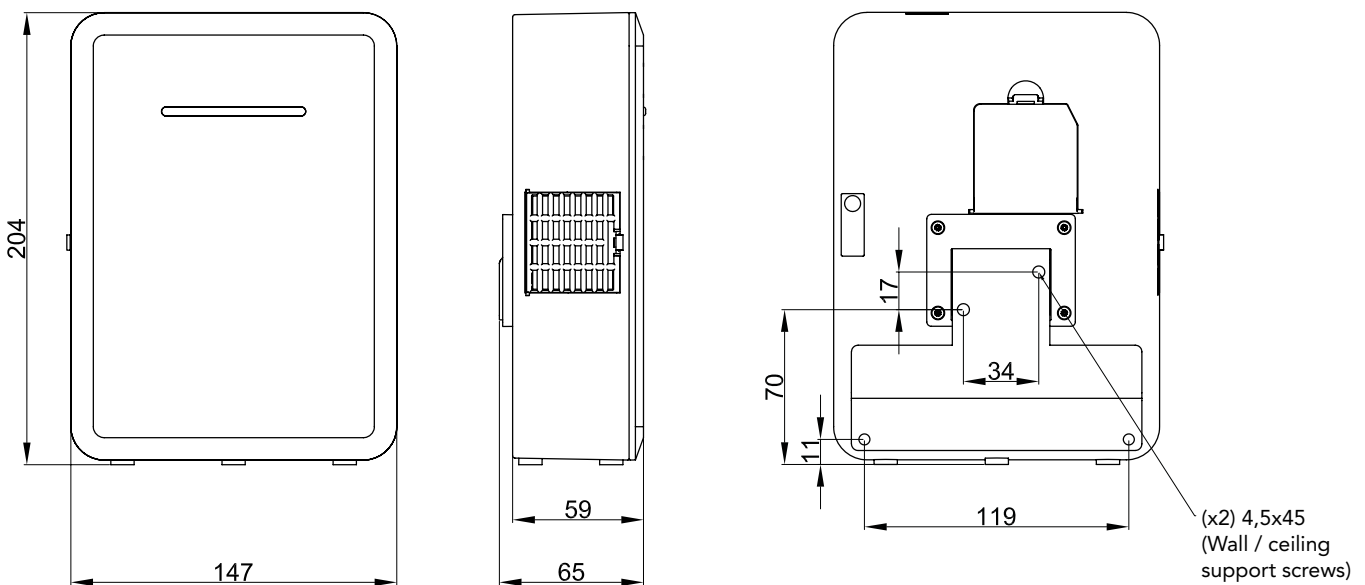

Maintenance

It is advisable to maintain the filter when replacing the consumable, by washing it with water and replacing it repositioning it so that it traps any particles that may damage the fan.



Nuvohla Lift works with interchangeable cartridges, which must be replaced every 3 months. Replacement can be done through the front cartridge service door by removing the main cover of the device to access, or through the rear cartridge service door behind the equipment.

Cartridge of hydrogen peroxide 4,95%.

Accessories

Nuvohla Lift can be anchored to the wall or ceiling thanks to its two-piece support.

The first is a plastic piece that holds the equipment, and that fits inside the second metal piece, which acts as a hanger and is fixed to the wall or ceiling at four points.

In case of wall fixing, two optional security screws can be installed, coinciding with the two lower holes of the metal support, and previously disassembling the front cover. In case of installation on the ceiling, these screws are mandatory, to ensure that the equipment is well fixed.



Disassembly of the front cover of the device (to access the cartridge from the front and to the security screws).

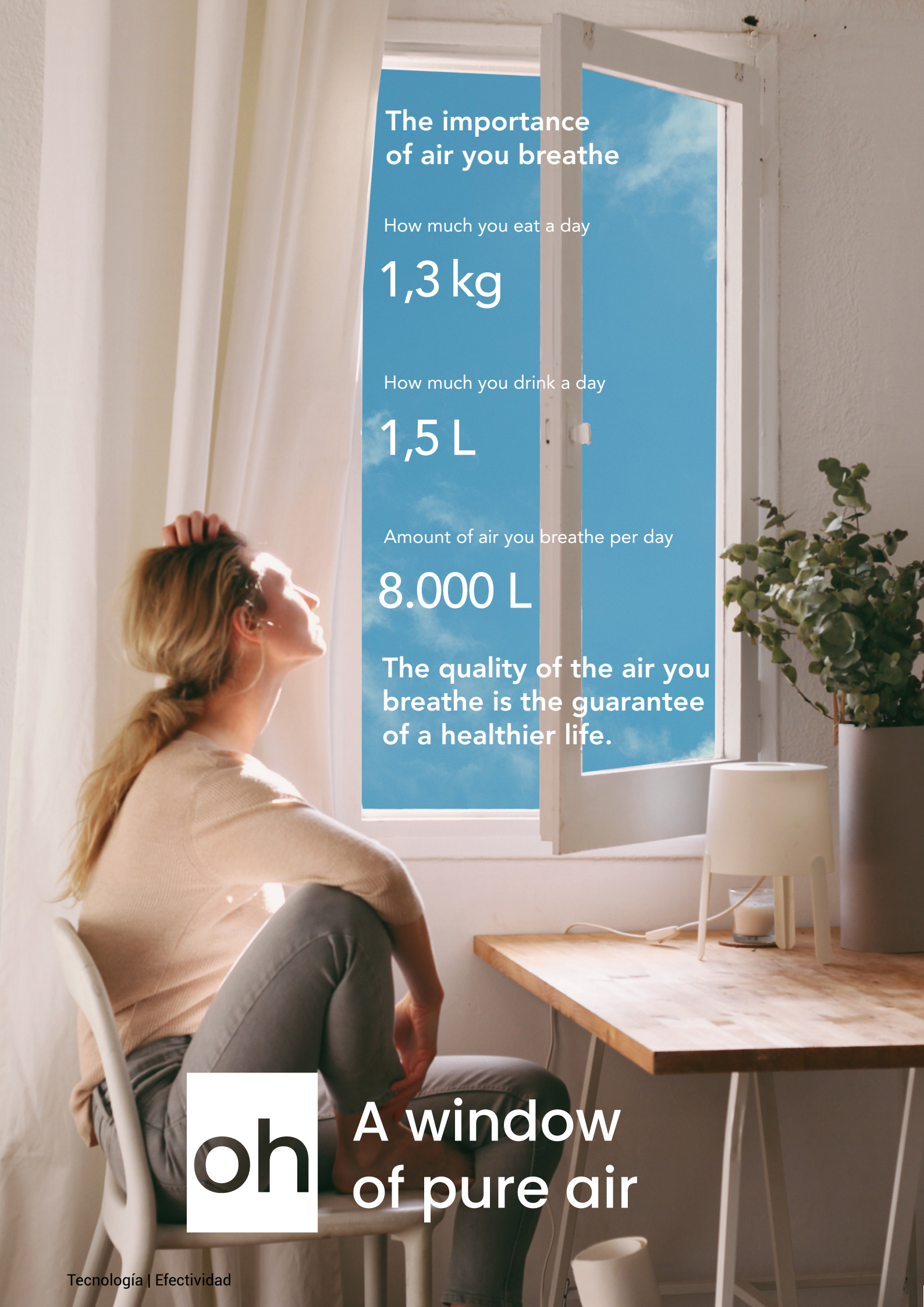

The importance
of air you breathe

How much you eat a day

1,3 kg

How much you drink a day

1,5 L

Amount of air you breathe per day

8.000 L

The quality of the air you
breathe is the guarantee
of a healthier life.

oh

A window
of pure air

Nuvohla Room provides continuous and active cleaning 24 hours a day



Natural detergent

Sanitization
and deodorization

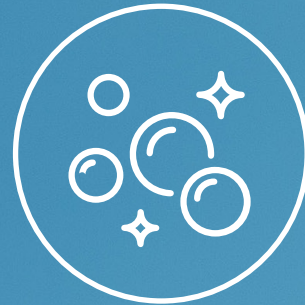

24/7

Safe continuous
purification

Without filters

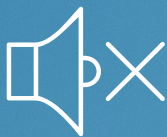

Silent

Low
consumption



GALLERY



Nuvohla Room
Medical Centre



Nuvohla Room
Office



Nuvohla Room
Domestic Use



Nuvohla Room
Domestic Use



Nuvohla Room
Domestic Use



Nuvohla Lift
Office



Nuvohla Lift
Elevator



Nuvohla Lift
Public Restrooms



Nuvohla Lift
Gym

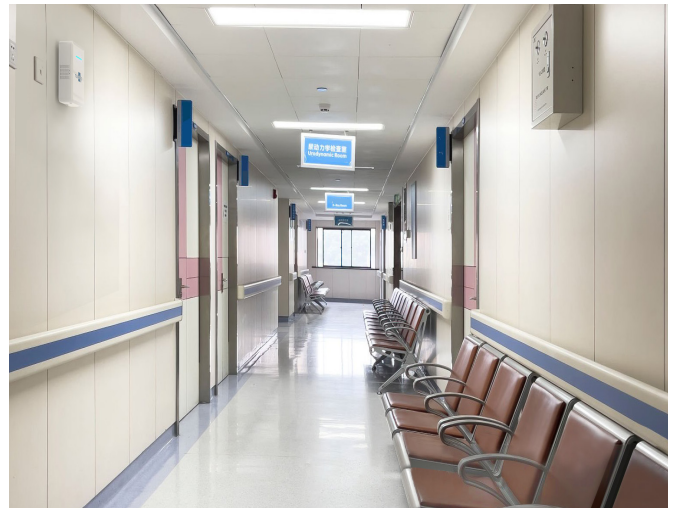

Nuvohla Lift
Waiting Room



Nuvohla Lift
Restaurant



Nuvohla Lift
Public Transport

Conca de Barberà, 5 - Pol. Ind. Pla de la Bruguera
E-08211 Castellar del Vallès (Barcelona) España
+ 34 93 715 99 88
airtecnicos@airtecnicos.com

www.airtecnicos.com



NOFCAT05621 2022R5 (11/11)
We reserve the right to modify design and
specifications without prior notice.

