

## Air curtain: TOP



### INSTALLATION, OPERATION AND MAINTENANCE MANUAL



*Please, read these instructions carefully before attempting installation  
Deliver this manual to the final user.*

#### SECURITY ADVISE SYMBOLS



*Attention, Danger, Safety Advice!*



*Danger from electric current or high voltage!*



*Injuries risk!*



*Danger! Do not stay underneath: Heavy load.*



*Important information.*

## INDEX

INSTALLATION .....	3
TRANSPORTATION AND STORAGE .....	9
OPERATING INSTRUCTIONS.....	9
ELECTRICAL SQUEMES .....	13
DATA SHEET .....	24
MAINTENANCE INSTRUCTIONS .....	26
REPAIRS AND REPLACEMENTS .....	30
TROUBLESHOOTING .....	35
ACCESSORIES.....	36
DECLARATION OF CONFORMITY.....	37
IDENTIFICATOR .....	39
GUARANTEE .....	39

# INSTALLATION

## Tips and recommendations for a good installation

### LENGTH

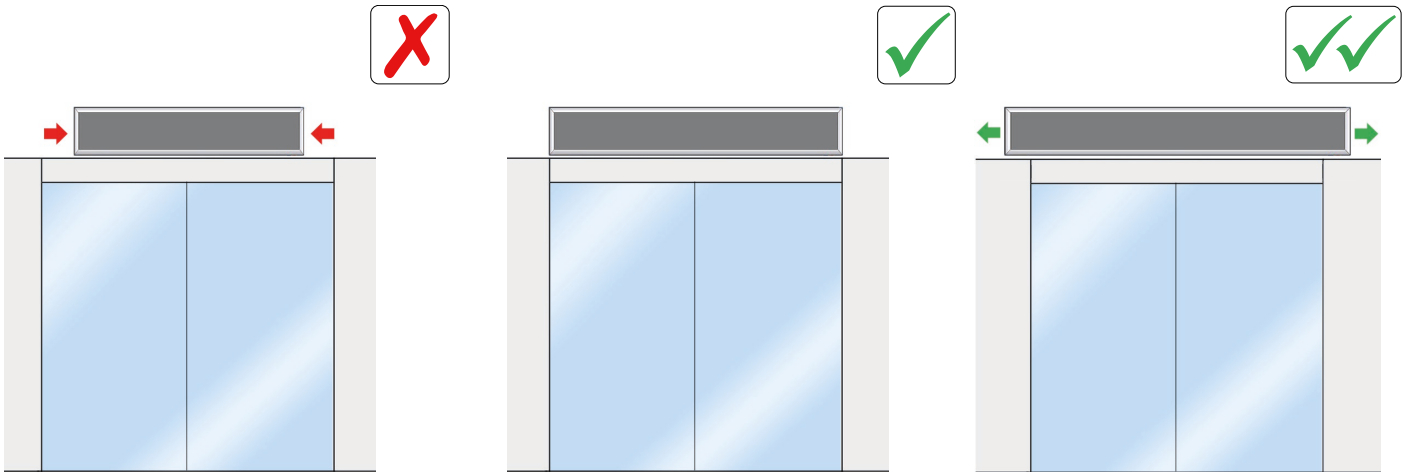

### CENTERED/ HEIGHT

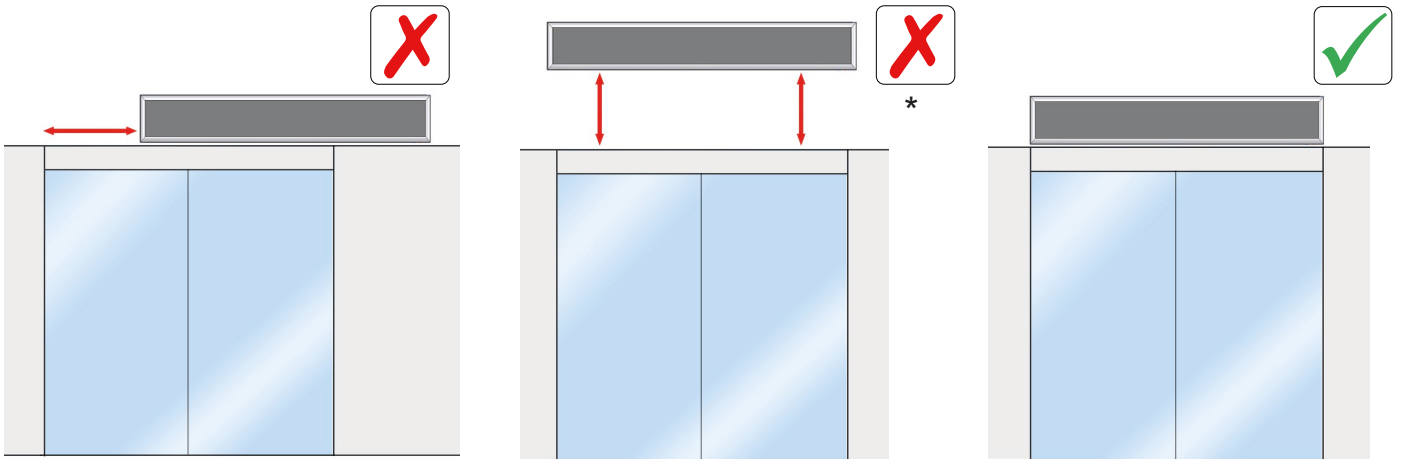

(\*) Unless it has been designed to be installed at that height.

### DOOR DISTANCE

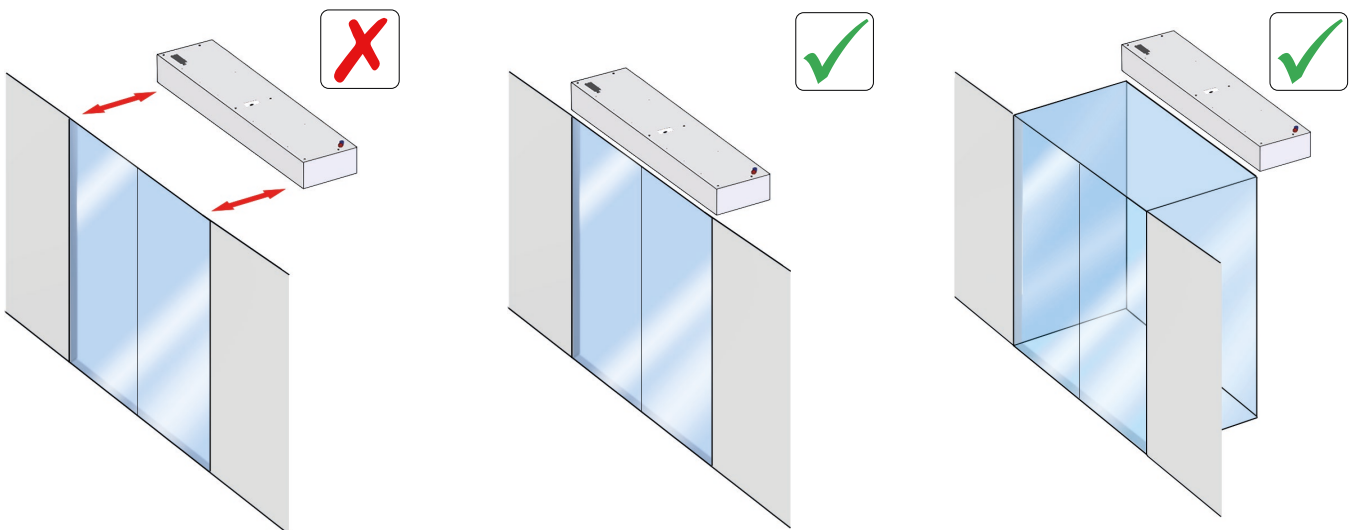

### AIR DISCHARGE

### AIR ASPIRATION

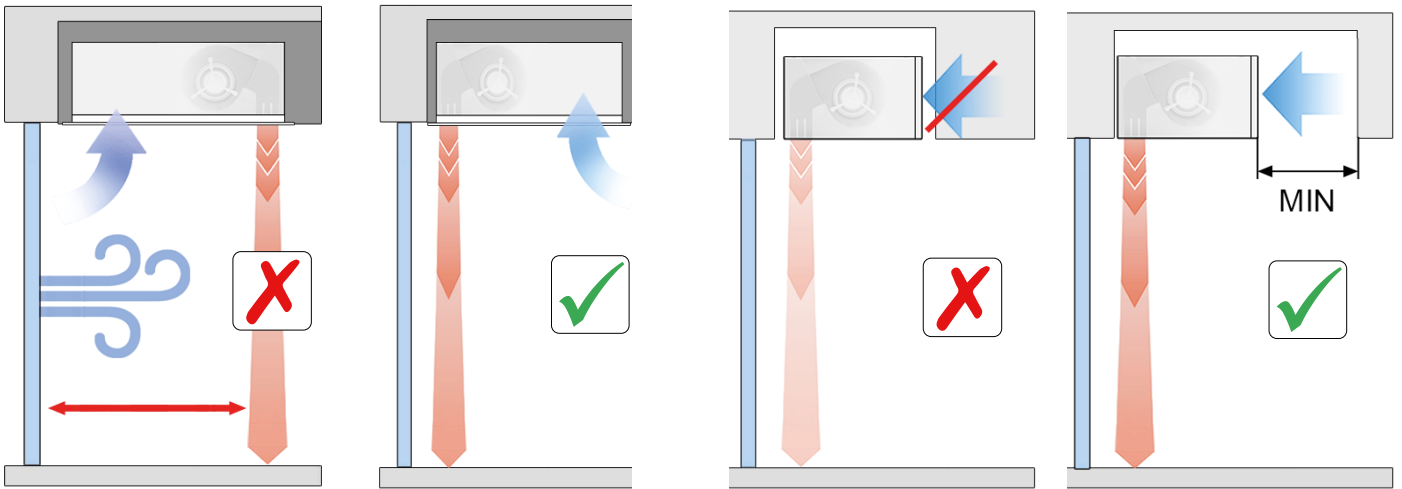

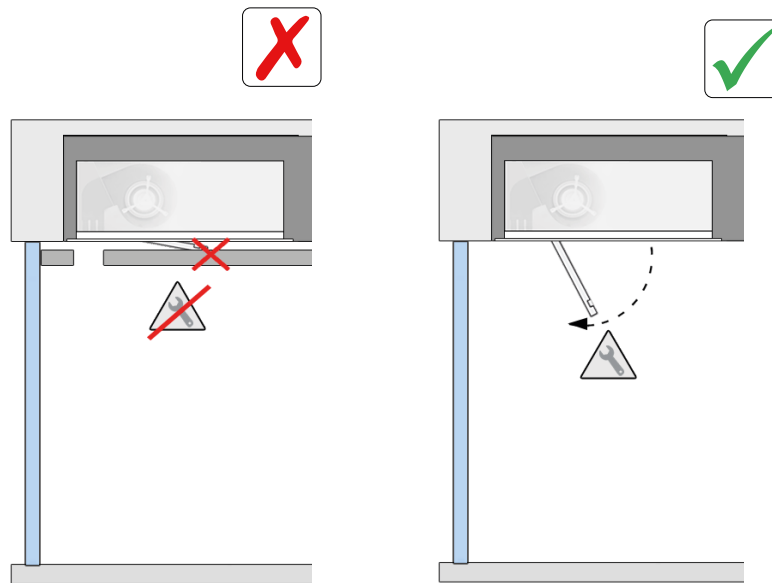

### MAINTENANCE ACCESSIBILITY

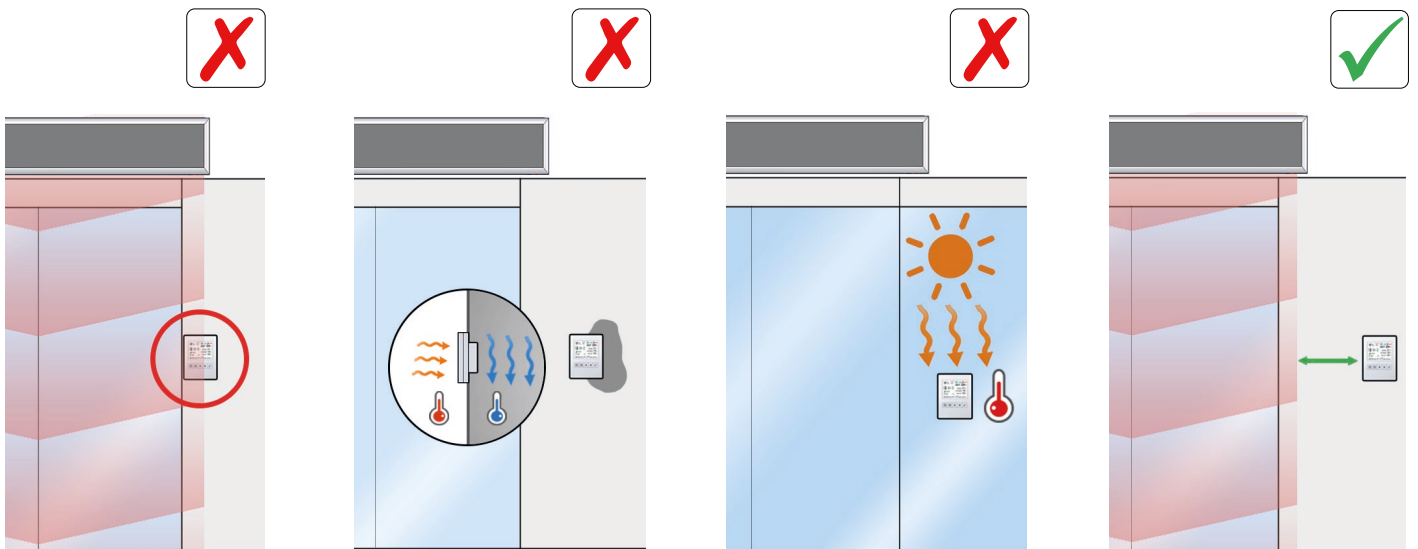

### CONTROL (CLEVER)



## Air curtain model: TOP

	<p>Installation work, connection, disconnection, electrical wiring, mechanical maintenance and service must be done by qualified people observing these instructions and in accordance with all applicable norms and standards. If the unit is operated with additional controller, please consider its specific instructions.</p>
	<p>There is no need to open the service door to connect the air curtain. All connections (power supply, control, water pipes when existing) and fixations are external. They are placed on top or lateral of the units. See how to open service door at repairs section.</p>
	<p>For safety, the air curtains never have to be stopped by disconnecting them from the main supply, always through the controller and waiting 10 minutes at least to disconnect the main supply. In case to not follow these instructions, the internal parts of the air curtain can be damaged.</p>

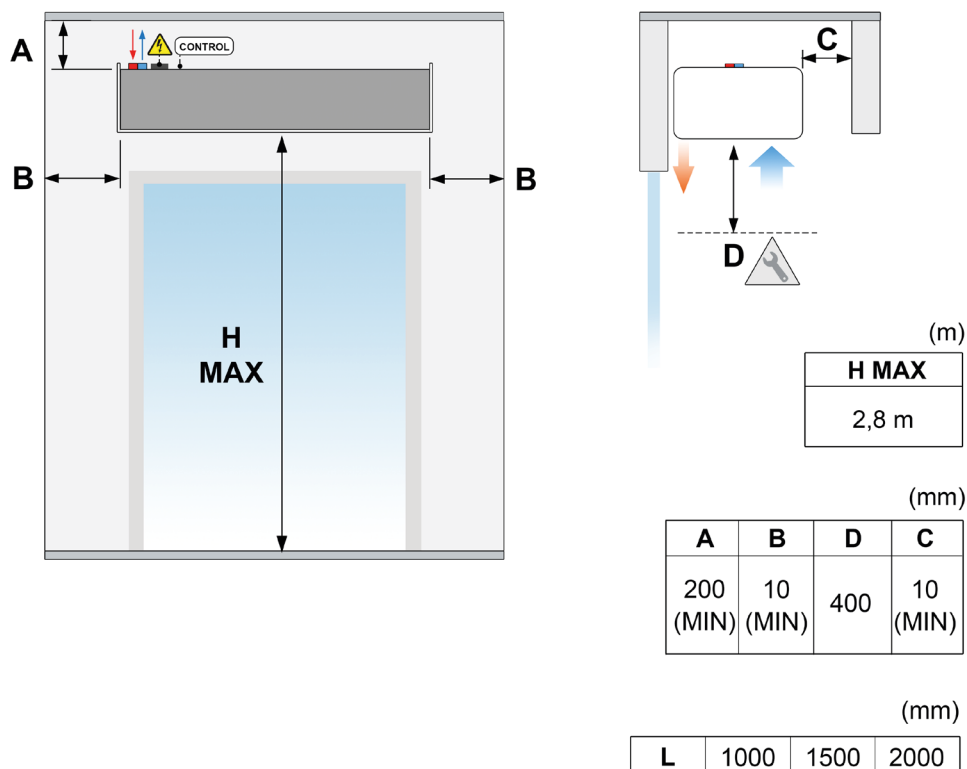

H MAX. Maximum recommended range, MIN. Recommended minimum distance.

The minimum recommended distance between the suction grille and any obstacle is 400 mm (Dimension D)

Dimension D: service opening distance.

# Connexion diagram

## Standard without heating, with water and electric heating 400Vx3 and 230 Vx1

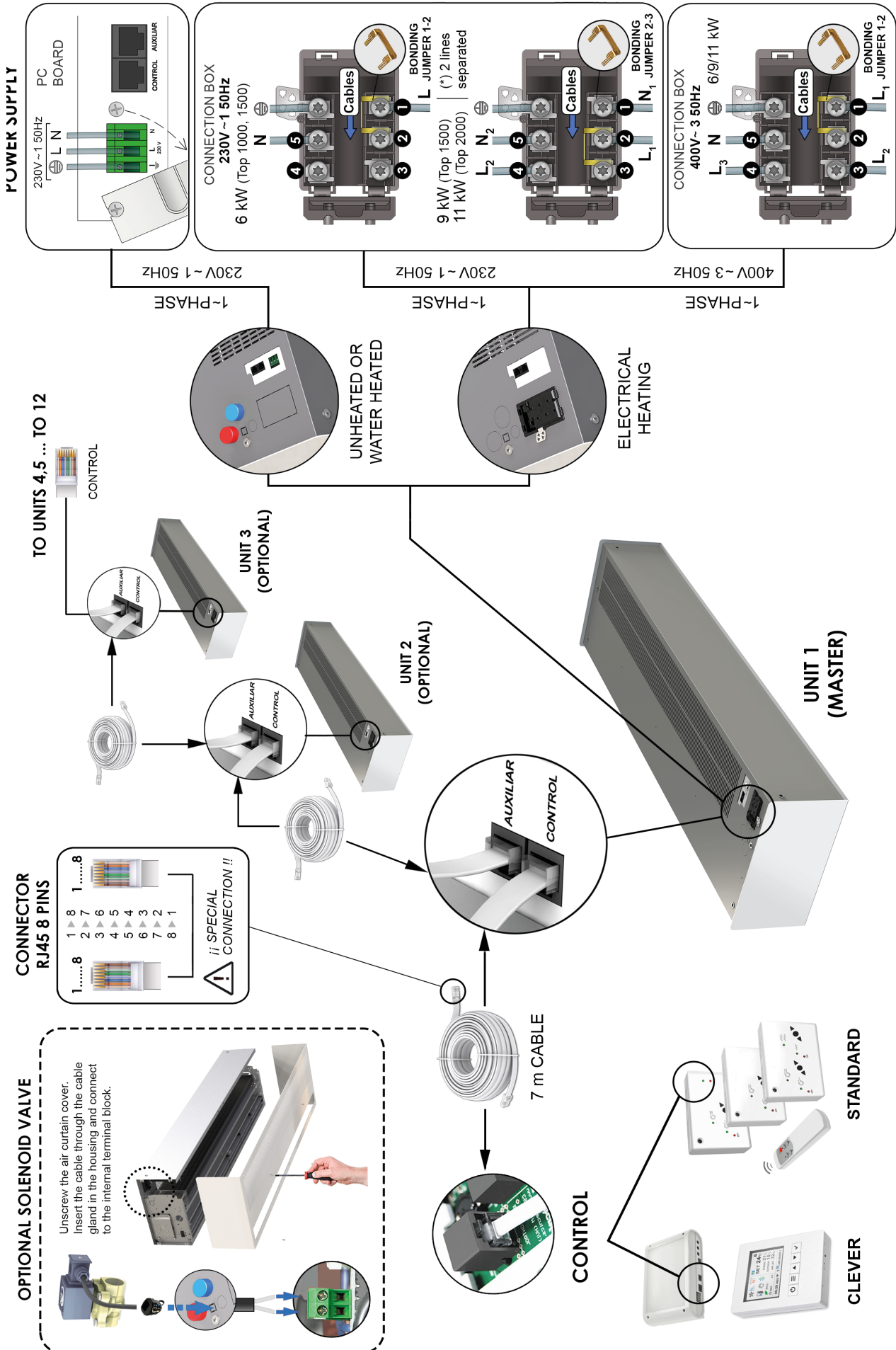

## Power supply

To give current to the device the connection should be done at the top exterior part of the air curtain:



### Water coil models:

For curtains without heating or with water heating, only the curtain must be connected to single-phase current at 230V for the operation of the fans directly to the PCB.

### Electrical heated models:

In the case of a curtain with an electrical heating element, connect a 400Vx3 three-phase power supply or a single-phase 230Vx1 power supply from the electrical heating element. Optionally, the battery power can be 230Vx3 triphasic (special diagram included). The single-phase current is only connected to one phase of the three-phase lines, plus a connection to the neutral (400 V).

Recommended maximum number of curtains connected to the same differential:

Model	Differential 30mA	Differential 300mA
TOP	20 uds.	20 uds.

Each installation must be reviewed by a specialist to ensure that there is no incompatibility with the selected differential and the connected curtains.

## Regulator and board

To connect the controller to the curtain, there is a connector located on the outside top of the air curtain. It is not necessary to open the curtain to connect it, except for internal connections. Use the 7 meter RJ45 cable supplied with the equipment. The communication between the controller and the board is digital and low voltage.



## Fixings

The curtain has several external fastening points depending on the weight and length (see situation in the model characteristics section).

The anchor must be sized according to the weights of each curtain indicated on the technical data page. The installation can be done using threaded rods, tensioners or other supports (see available supports in the accessories section).

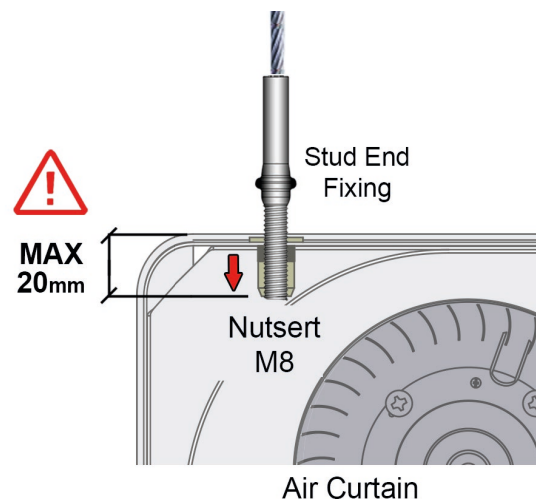

## Water coils

The air curtains with water coil have a 230Vx1 output to optionally connect a solenoid valve (it opens or closes the water inlet to the heat exchanger of the coil). This outlet can also be used for other low amperage electrical appliances (10A).

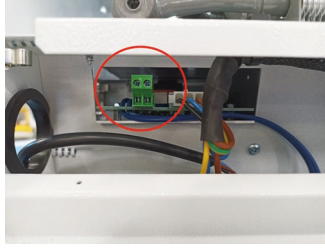

Recomendations:

- Close the hot water circulation (valve) to avoid overheating of the motors while the equipment is off. Optionally, the solution with solenoid valve is also available.
- In the installation of the building, two shut-off valves (outflow and return) should be provided to be able to disassemble the equipment without problems.
- Mount a bleeding valve at the highest point of the heating section.

The ambient temperature must always be higher than +4° C. Otherwise, the equipment must be provided with a frost protection device (antifreeze sensor).

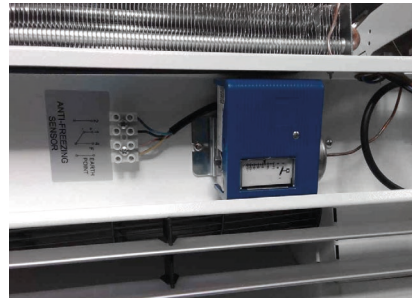

The water coils contain a drain screw in the collector area.

## Electrical heating element

The electrical heating element is made of three or six bar-shaped resistances (depending on the model) that, combined with each other, provide two heating stages. The control is carried out by one or two PRBEO (depending on the model) up to 12kW included.

All the batteries are electrically and electronically protected against overheating (see section “Operating instructions”).

Electric controllers have the option of including an external thermostat to control heating on and off based on temperature.

During the first uses, the electric battery can give off some odor that disappears in a few days.

According to battery power, the regulation is carried out by:



Power (kW)	Regulation type
6 / 9	1 PRBEO
12	2 PRBEO

## TRANSPORTATION AND STORAGE



**Warning! Heavy load.**  
**Do not stand under the suspended load during transportation or assembly.**

Store in a dry place protected from the environment. If the package is opened, cover the curtain to protect it from the dust. Do not step on or place heavy loads on it to avoid damage to the material. Storage temperature between -20 °C and +40 °C.

When transporting the material, you must ensure that it is not damaged by the forklift. (possible penetration of the fork in the packaging). Observe the instructions on the packaging for correct manipulation of the product.



## OPERATING INSTRUCTIONS



**For safety, the air curtains must never be stopped by disconnecting the current, always do it through the controller. If the power is turned off to turn off the shade, or within ten minutes of turning it off with the controller, internal components may be damaged.**

### Characteristics of regulation boards

Depending on the type of fan, the air speed is regulated by:

- External rotor motor: regulated by capacitor connection.

### Common characteristics to all regulators

There are various regulator models depending on the customer's needs: timers, antifreeze detectors, thermostats, etc.

- 2 fan speeds.

- Memory: guarantees that, in the event of a power outage, the selected speed is maintained when service is restored. This function can be activated/deactivated using the ON/OFF switch located inside the regulator.

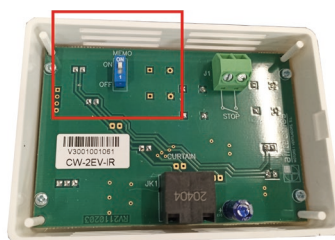

- **RJ45 cable and digital communication:** they have a fast connection with a telephone type cable and digital communication between the regulator and the curtain. This type of communication is reliable even over long distances.

- **External start-stop:** inside the regulator there is the possibility of connecting a normally open contact (1,2) that governs the on/off of the equipment through any external device. The contact is potential free. When the contact is closed, the curtain has a 30-second delay before stopping. It can be used for a timer, temperature sensor, fire alarm, PLC, etc

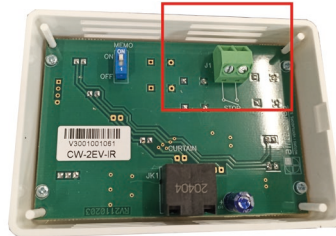

- **Remote control:** all standard dimmers have an IR receiver that allows them to use a remote control.

## Common Features of water coil Curtain Controllers

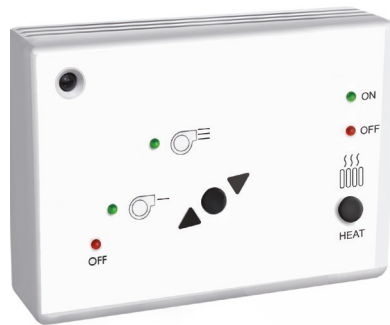

Controller for curtains with water coil

- **Heating ON/OFF:** with the “HEAT” ON/OFF button you manually activate or deactivate the 230Vx1 power supply to the solenoid valve to open or close the passage of water to the coil. This 230x1V output is located in the upper part of the unit, next to the regulator’s RJ45 cable connection.
- **External thermostat (electrovalve control):** If you want to control the water inlet to the coil by means of a thermostat, the thermostat must be installed in series with the solenoid valve. In this way, when the set temperature is reached, the solenoid valve closes the passage of water.
- **Safety thermostat:** in the event that the internal temperature reaches 60°C and is not selected the maximum speed of the curtain, automatically the speed of ventilation increases 1 speed every 2 minutes to evacuate the excess thermal energy from the interior. It will continue at maximum speed until the interior temperature drops below 50°C.

Safety operation is indicated by a flashing LED. If safety is activated usual way you have to find out the cause. Most likely you will need to increase the frequency of cleaning the suction grille.

For example, an obstruction in the suction grille, the motor stopped, a temperature high ambient temperature in an installation without a room thermostat, etc., would cause the curtain to speed up automatically.

It also prevents the air expelled by the curtain from exceeding 60°C (sensing temperature). excessive for people).

## Characteristics common to all controllers for electric battery

System with 2 ventilation speeds and 2 heating stages (C1, C2).

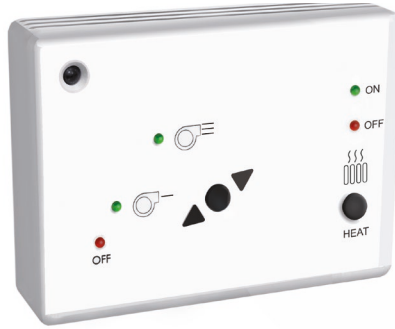

2 heating power:

- 1000 / 1500 air curtain size: C1=2/3 C2 = 3/3 or 1
- 2000 air curtain size: C1= 1/1 C2=2/2 or 1

Limited heating: for safety reasons of the device, the references 1000 of 9kW have the heating power limited by the ventilation speed that we have selected, as follows:

Selected speed	Heating stage
V1	1st heating stage
V2	2nd heating stage

To apply this limitation, the jumper from JP1 of the control is removed at the factory.

In the rest of the references, any air speed can be selected with any heating power.

Furthermore, for equipment safety reasons, the heating does not work if some fan speed is not running.

Warning: If the ambient air temperature is high and we set the curtain to maximum heating and minimum ventilation, the electronic security will be activated repeatedly.

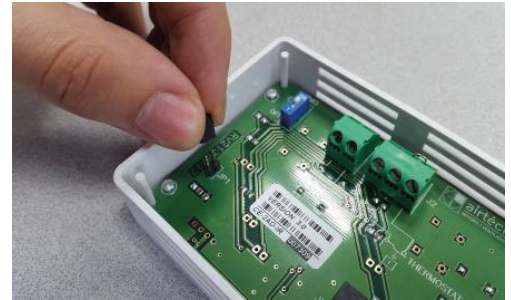

**Delay thermostat:** when the device is stopped with the heating on, there is an increase in temperature inside it that could damage its components due to the thermal inertia of the electrical resistors. To avoid this, the curtain continues to work up to 90 seconds after stopping; and if when stopping the curtain, the temperature rises above 50 °C, the equipment goes to maximum speed and does not stop until the excess thermal energy is evacuated.

**Safety thermostat:** when the curtain works with heating and the internal temperature rises above 60°C, the safety function is activated: it increases 1 air speed every two minutes until reaching the maximum speed. Then, it starts down 1 stage of heating until it stops. If it persists, after two minutes, it blocks the heating. To unlock it you have to remove the current from the curtain. If at any time the internal temperature does not reach the limit of 60 °C and a downward trend begins, this process is interrupted and returns to normal.

A delay in cleaning the suction grille or a high ambient temperature could temporarily activate this function.

**Room thermostat:** the curtain is equipped with the necessary contacts to be able to install, if desired, a room thermostat that stops the heating when the set temperature is reached. It is recommended when the equipment is installed in a closed area of reduced dimensions. If you install the room thermostat, remove the jumper between terminals 4 and 5 of the controller and connect the thermostat there.

The air speed and heating stage are indicated by a continuously lit LED, while the safety speed is indicated by a flashing LED. The heating lockout is indicated by its OFF LED flashing at a faster rate.

## Special regulators

---

If there is a need to be able to control more parameters (intelligent proactive regulation, automatic/manual operation, door delay, time programmer, energy saving mode, multi-device management and BMS Modbus connection, among others) ), there are two controllers that allow much more possibilities than the standard controller, especially the Clever. The following regulators have their own manual:

- Hand Auto
- Clever control

## Remote Control Features

---

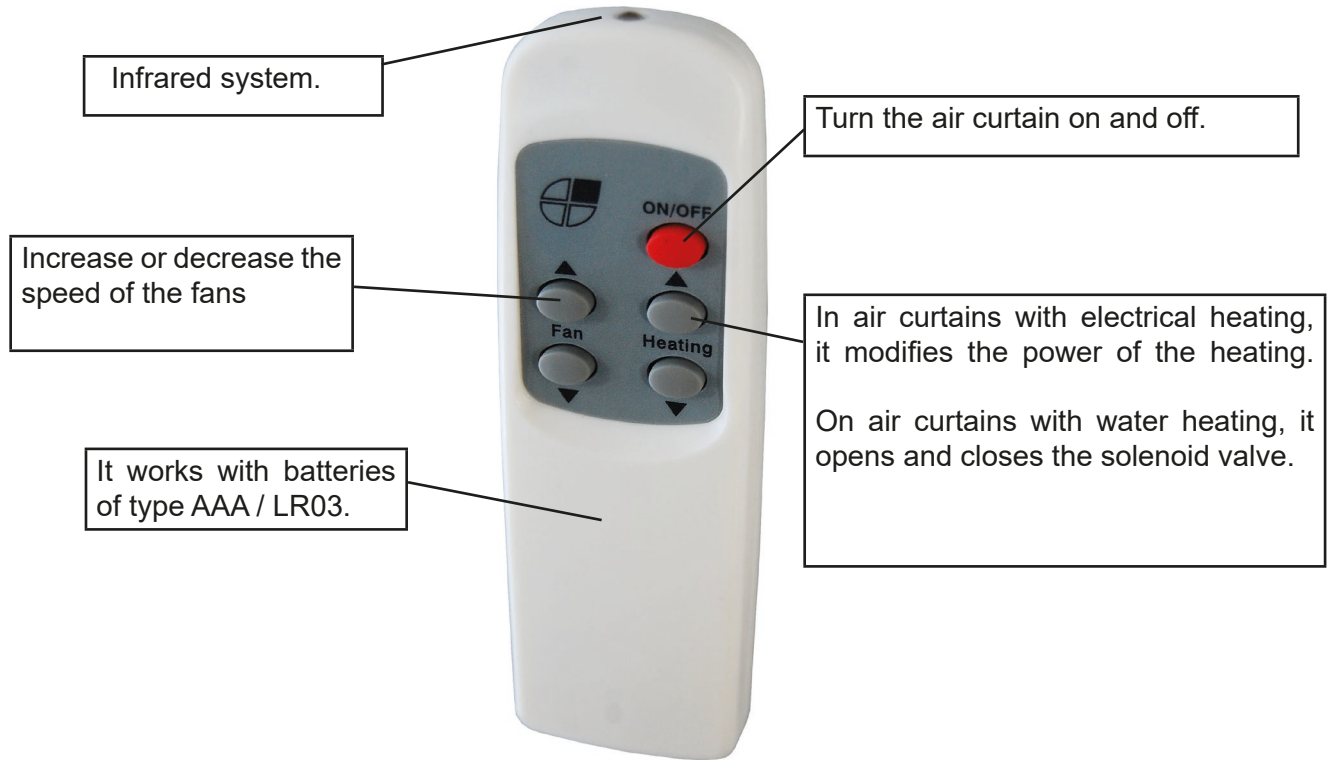

# ELECTRICAL SQUEMES

## Water heated air curtain or non heated with standard control models 1000 and 1500. Scheme AIRDOE07050

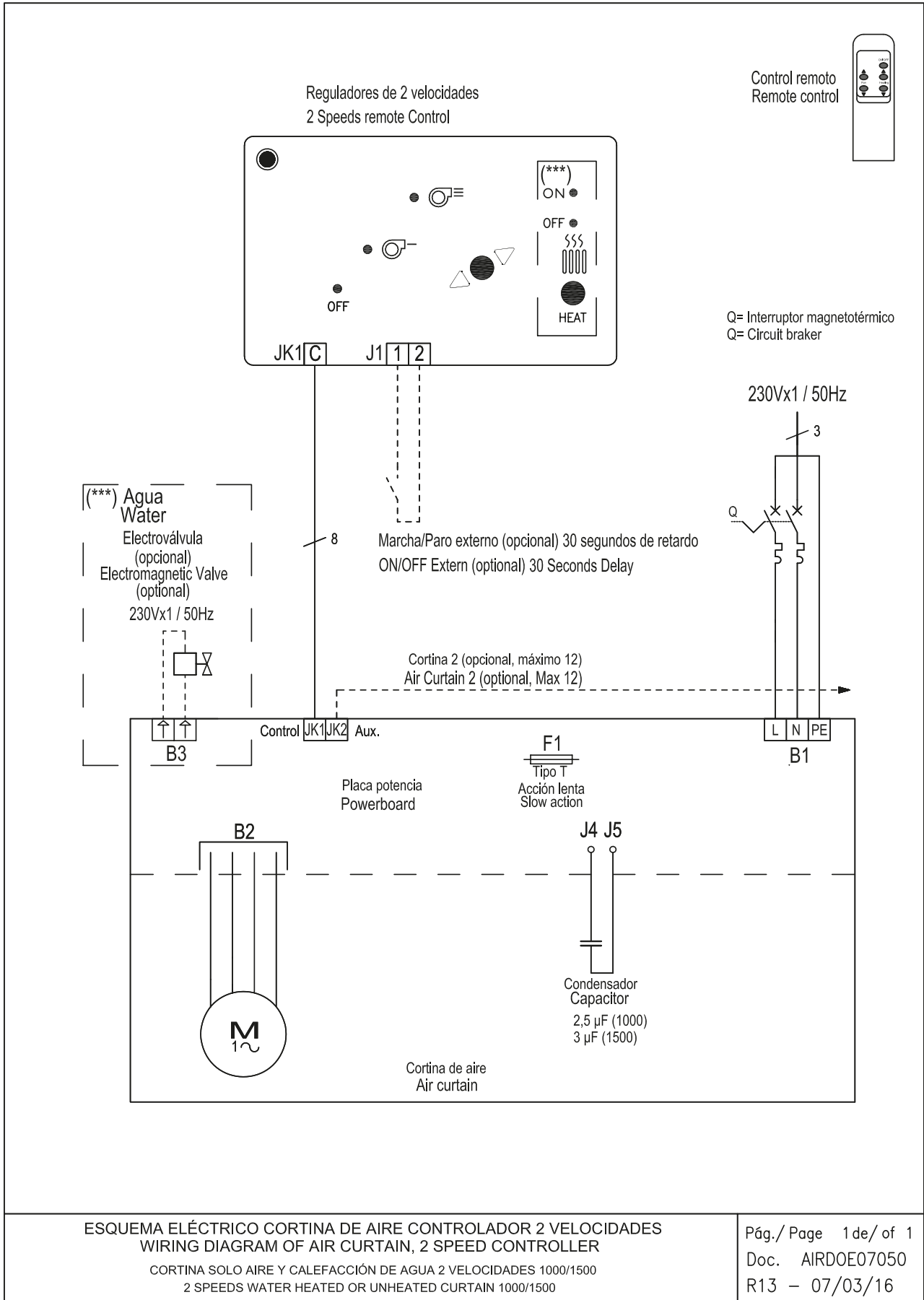

In case there is a need to connect the curtain to a PLC, the corresponding diagram is attached.

**Water heated air curtain or non heated with Hand Auto models 1000 and 1500.  
Scheme AIRDOE07060**

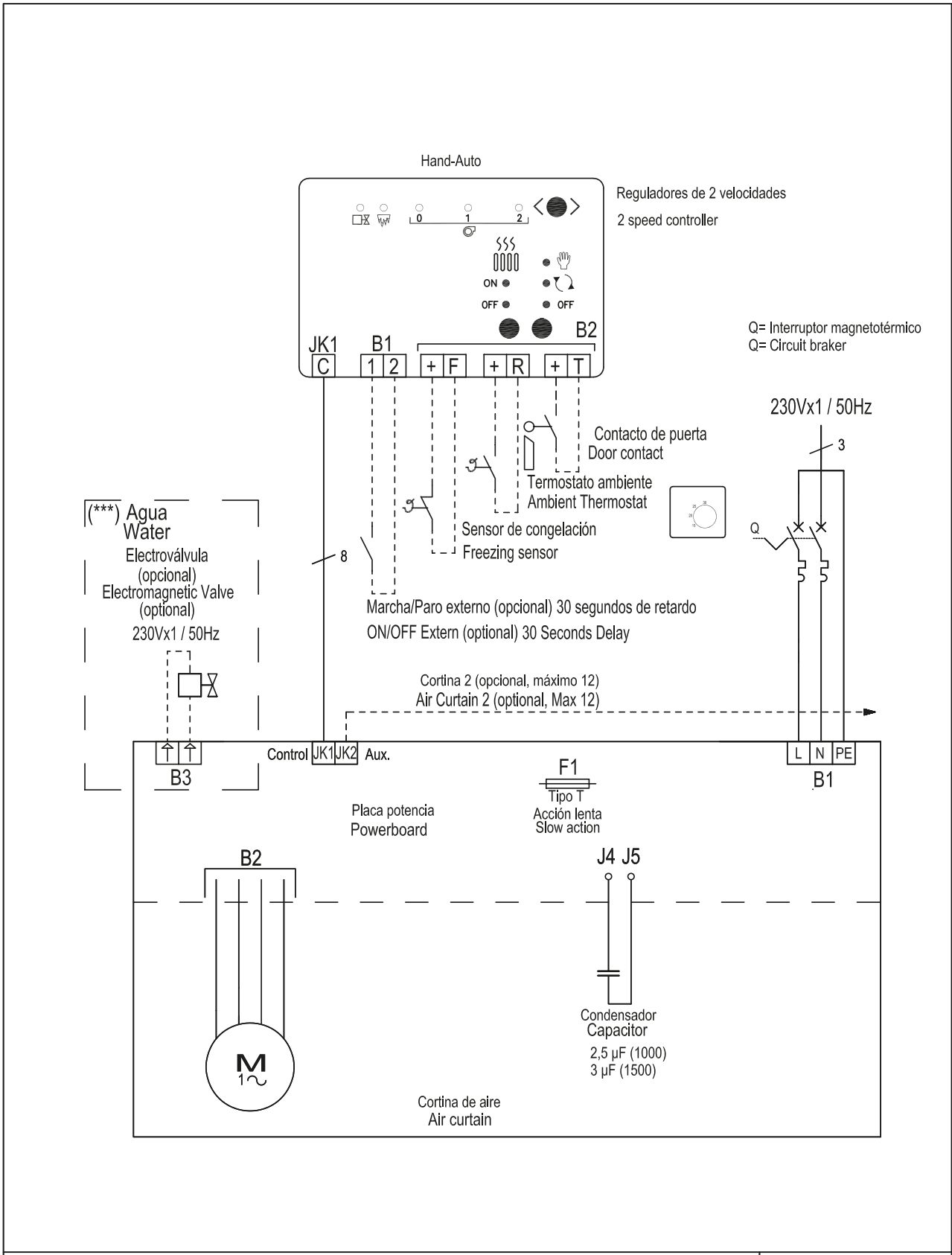

ESQUEMA ELÉCTRICO CORTINA DE AIRE CONTROLADOR 2 VELOCIDADES HANDAUTO  
WIRING DIAGRAM OF AIR CURTAIN, 2 SPEED CONTROLLER HANDAUTO

CORTINA SOLO AIRE Y CALEFACCIÓN DE AGUA 1000/1500  
2 SPEEDS WATER HEATED OR UNHEATED 1000/1500

Pág./ Page 1 de/ of 1  
Doc. AIRDOE07060  
R14 - 01/09/20

In case there is a need to connect the curtain to a PLC, the corresponding diagram is attached.

**Electric curtain 400V~3 with PRBEO and electric control models 1000 6kW and 1500 6 and 9kW.  
Scheme AIRDOE07100**

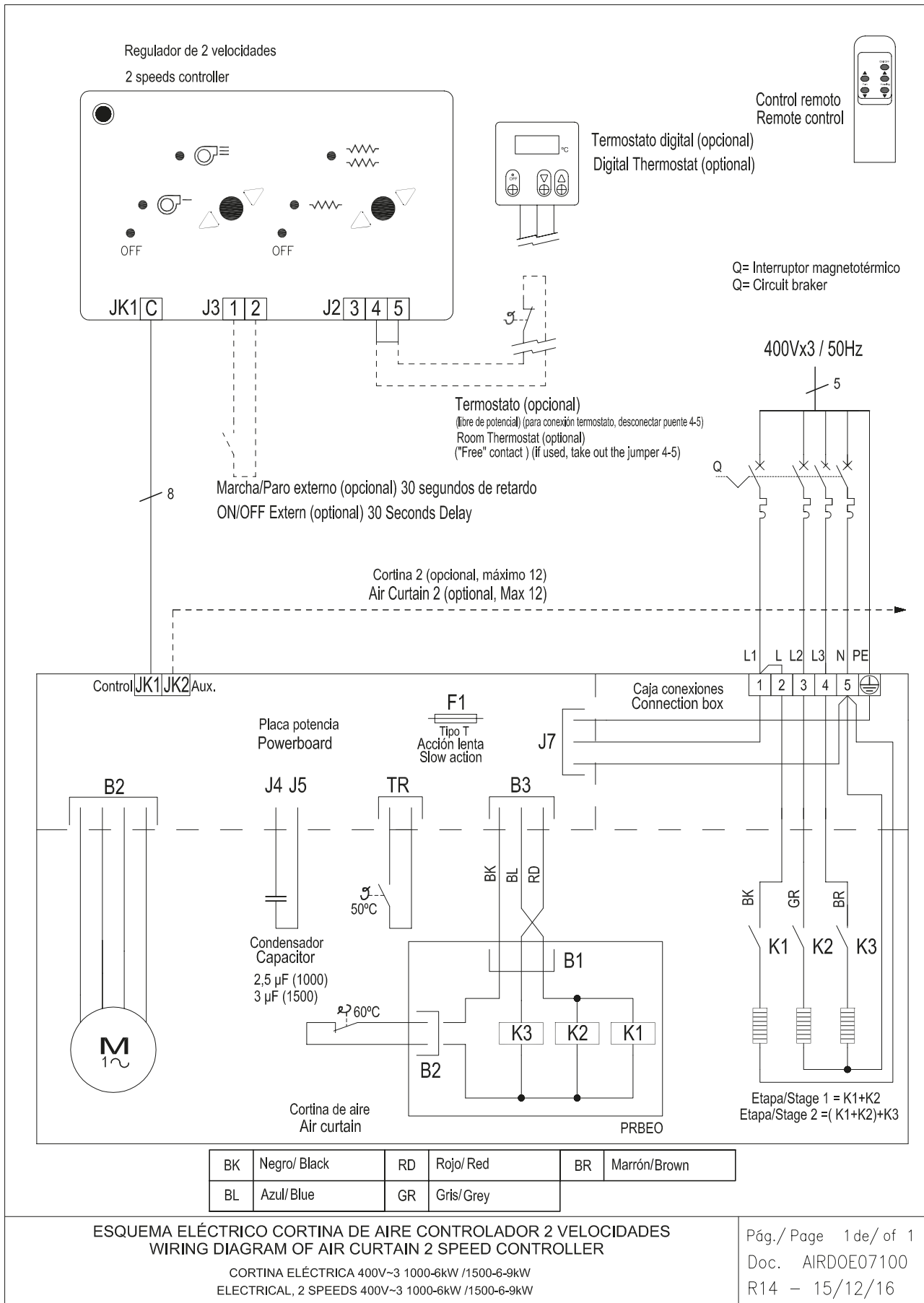

In case there is a need to connect the curtain to a PLC, the corresponding diagram is attached.

# Electric curtain 400V~3 with PRBEO and electric control 1000-9kW. Scheme AIRDOE07200

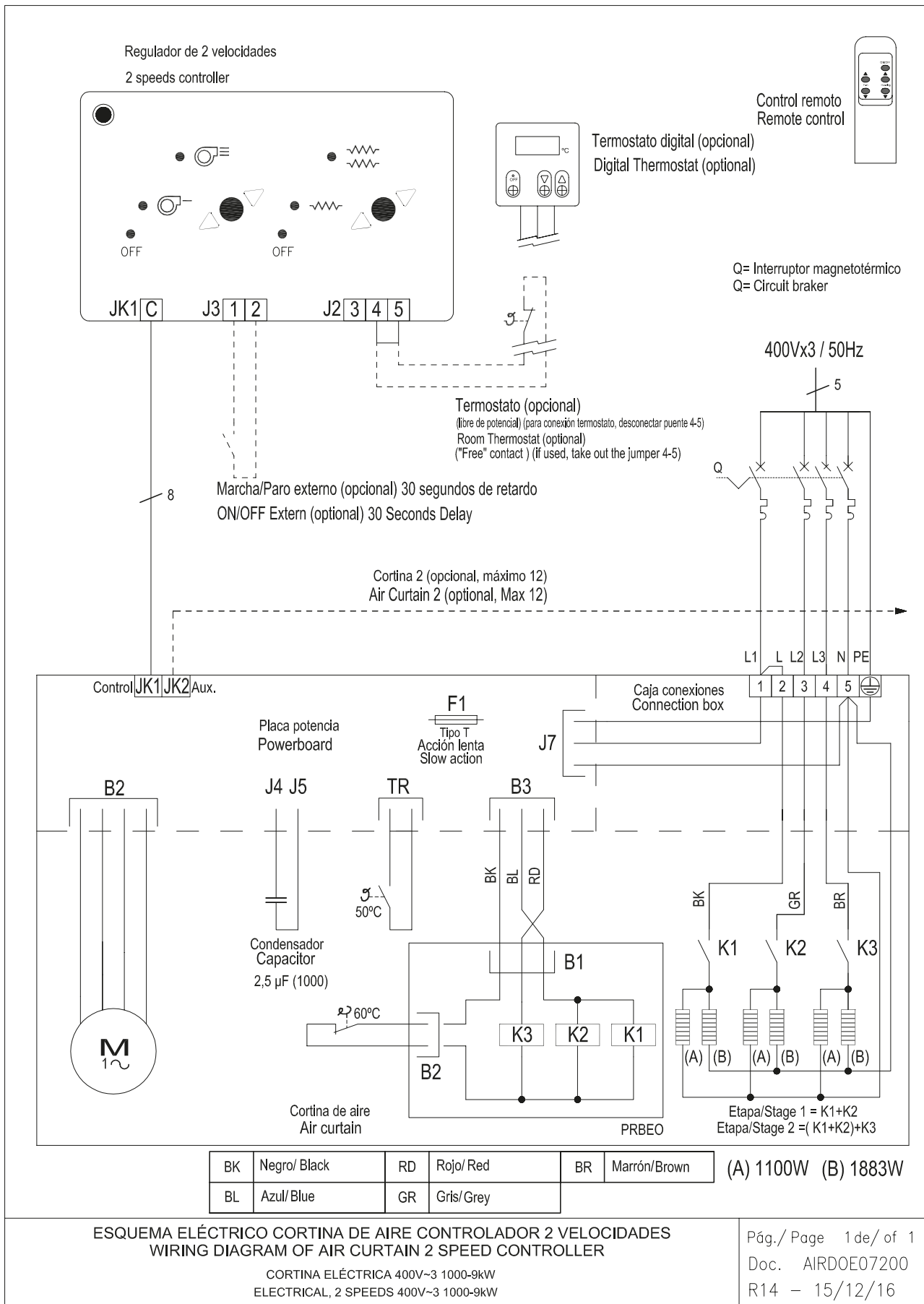

In case there is a need to connect the curtain to a PLC, the corresponding diagram is attached.

**Electric curtain 230V~1 models 1000 and 1500 6 kW and electric control.  
Scheme AIRDOE07190**

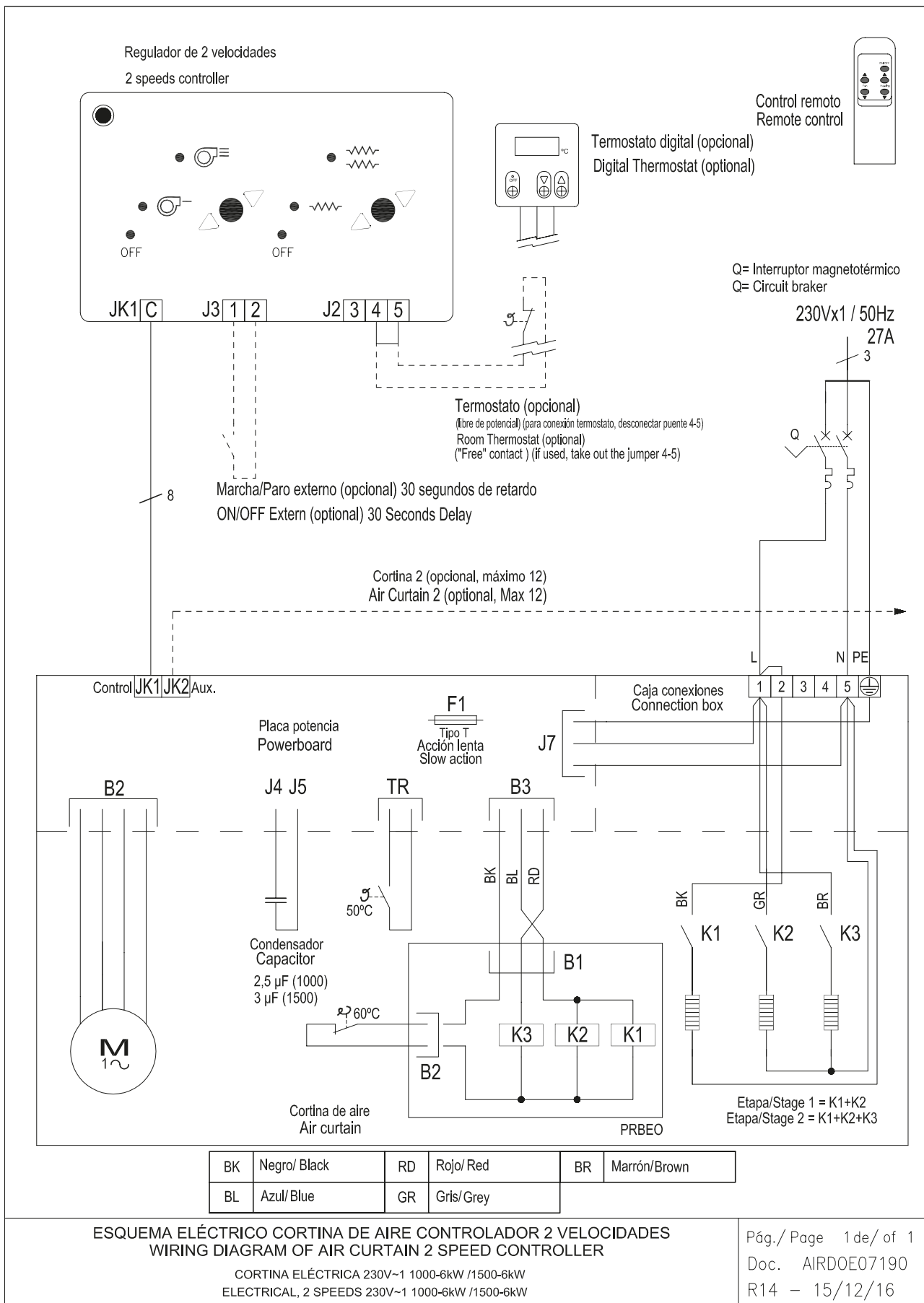

In case there is a need to connect the curtain to a PLC, the corresponding diagram is attached.



# Electric curtain 230V~1 and electric control 1500 E230-9kW. Scheme AIRDOE07195

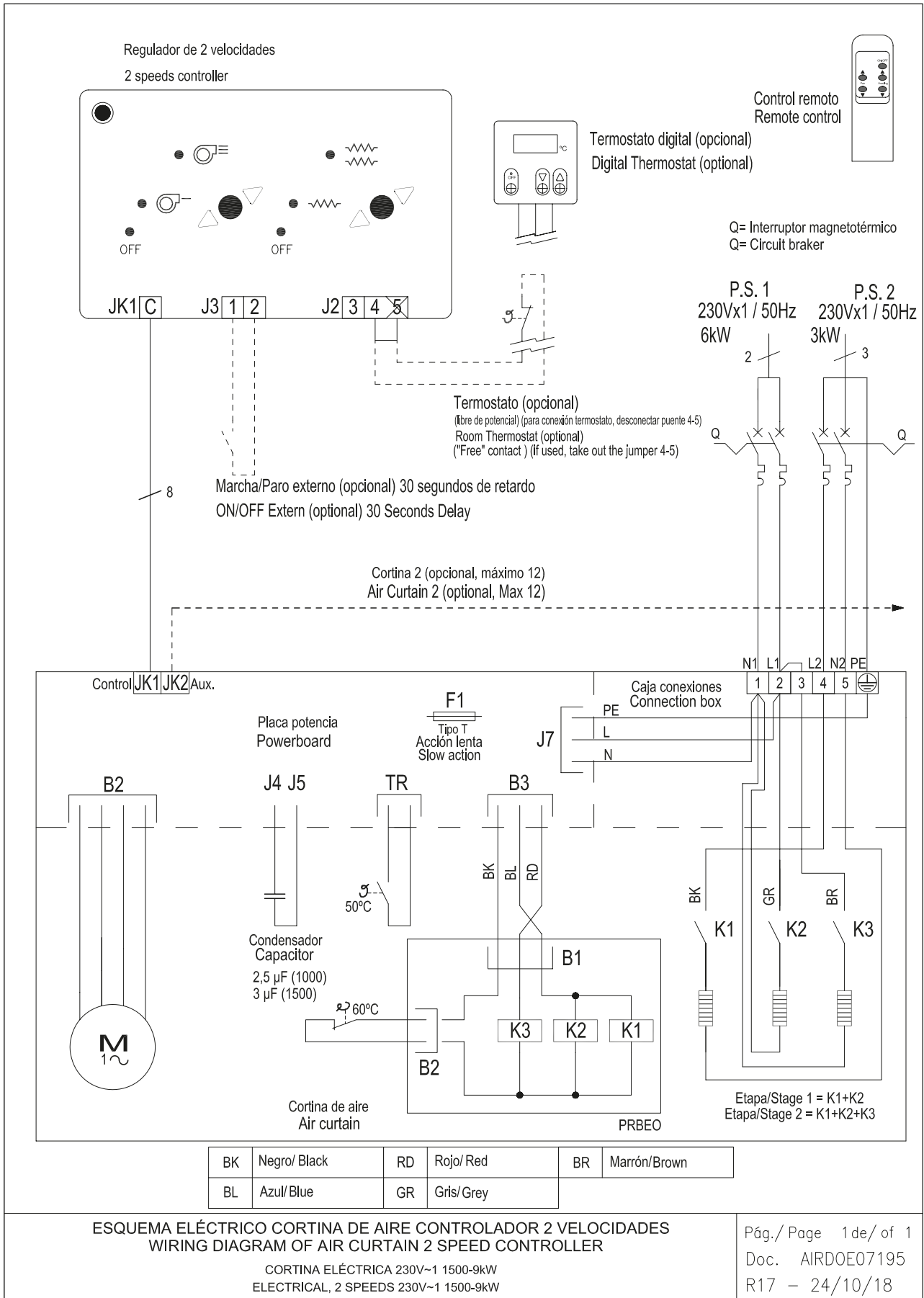

In case there is a need to connect the curtain to a PLC, the corresponding diagram is attached.

**Water heated air curtain or non heated with standard control model 2000.  
Scheme AIRDOE07150**

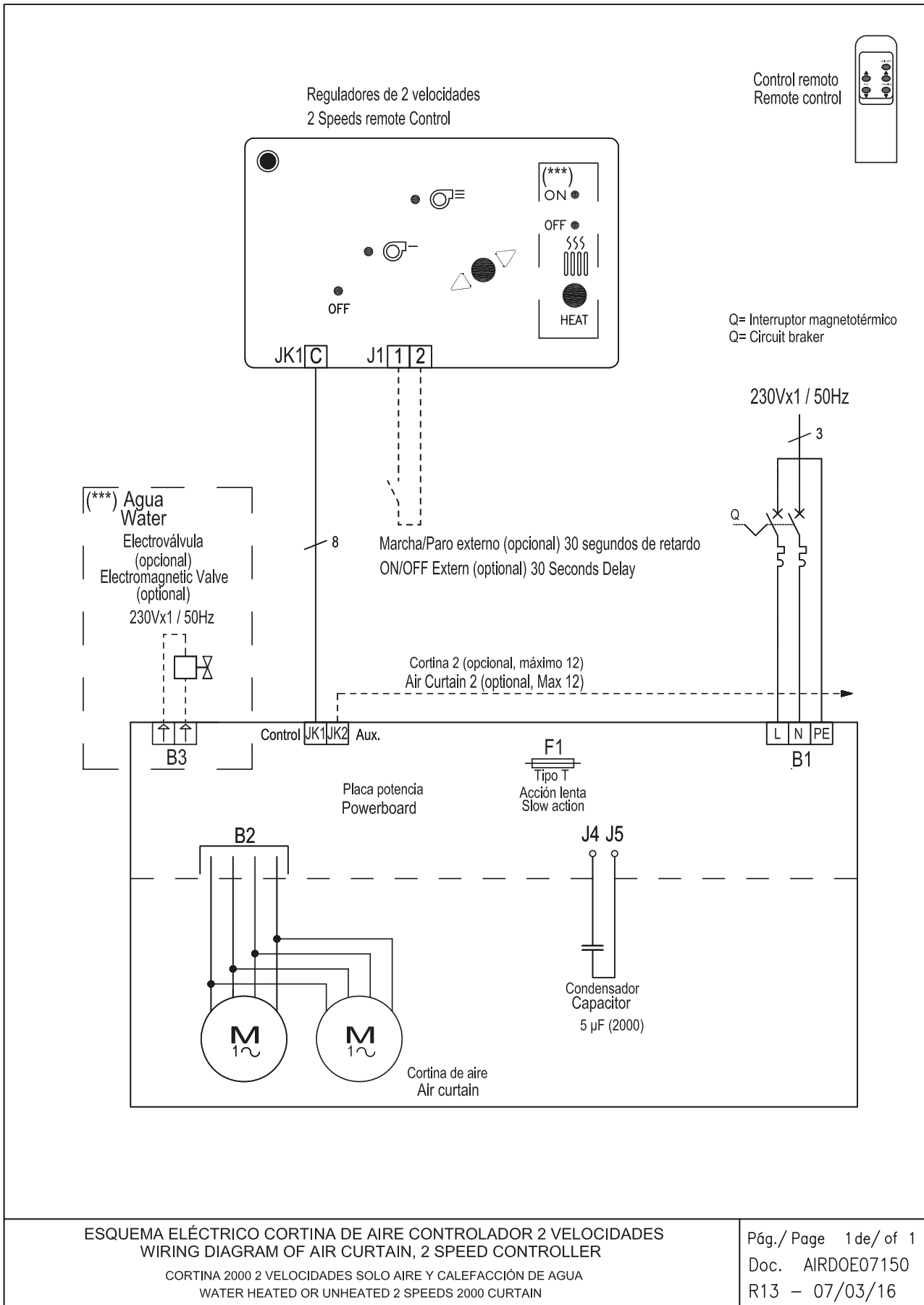

In case there is a need to connect the curtain to a PLC, the corresponding diagram is attached.

**Non-heated air curtain or with water heated model 2000 with Hand Auto.  
Scheme AIRDOE07065**

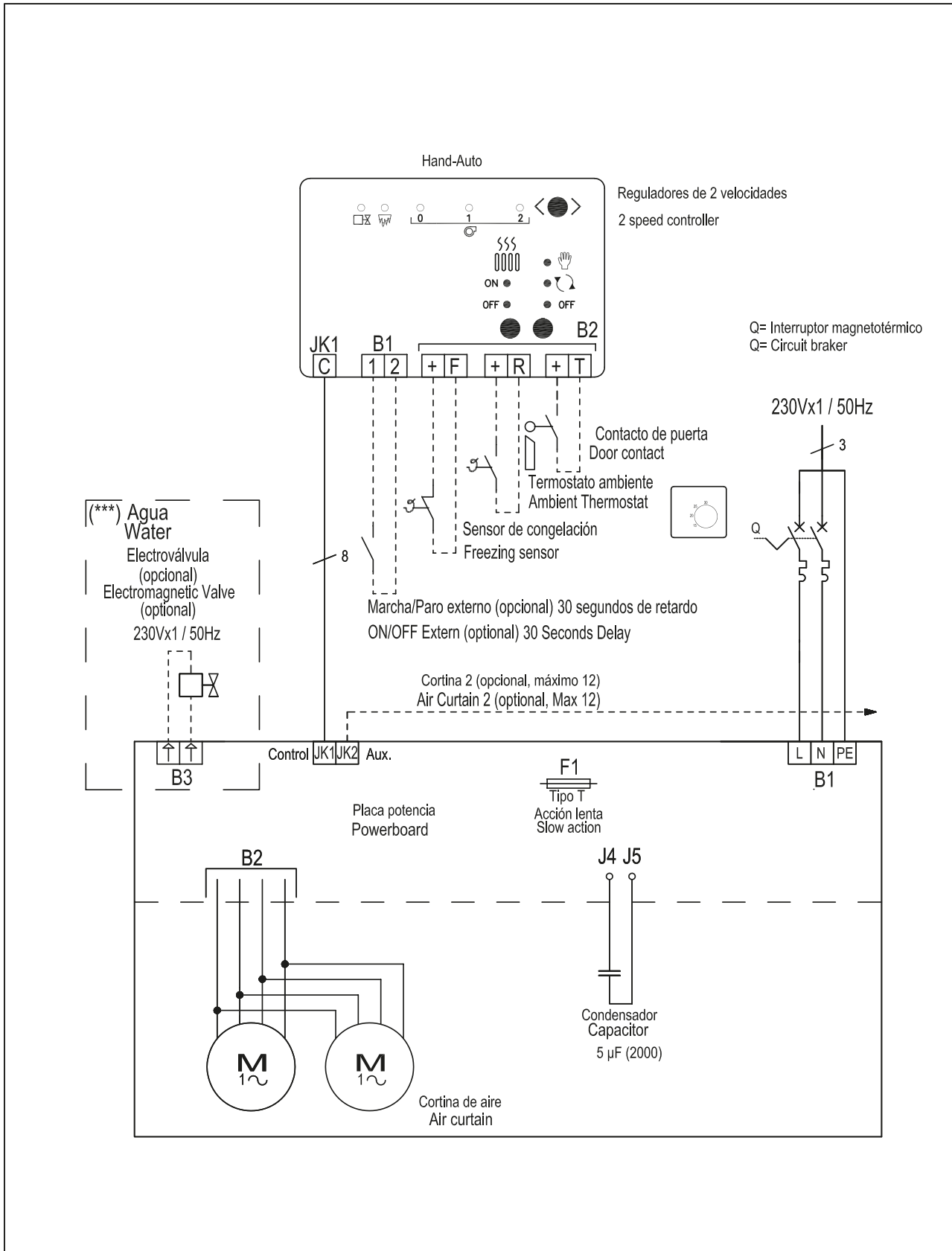

ESQUEMA ELÉCTRICO CORTINA DE AIRE CONTROLADOR 2 VELOCIDADES HANDAUTO  
WIRING DIAGRAM OF AIR CURTAIN, 2 SPEED CONTROLLER HANDAUTO

CORTINA SOLO AIRE Y CALEFACCIÓN DE AGUA 2000  
2 SPEEDS WATER HEATED OR UNHEATED 2000

Pág./ Page 1 de/ of 1  
Doc. AIRDOE07065  
R14 - 01/09/20

In case there is a need to connect the curtain to a PLC, the corresponding diagram is attached.

# Electric curtain 400V~3 model 2000 and electric control. Scheme AIRDOE07160

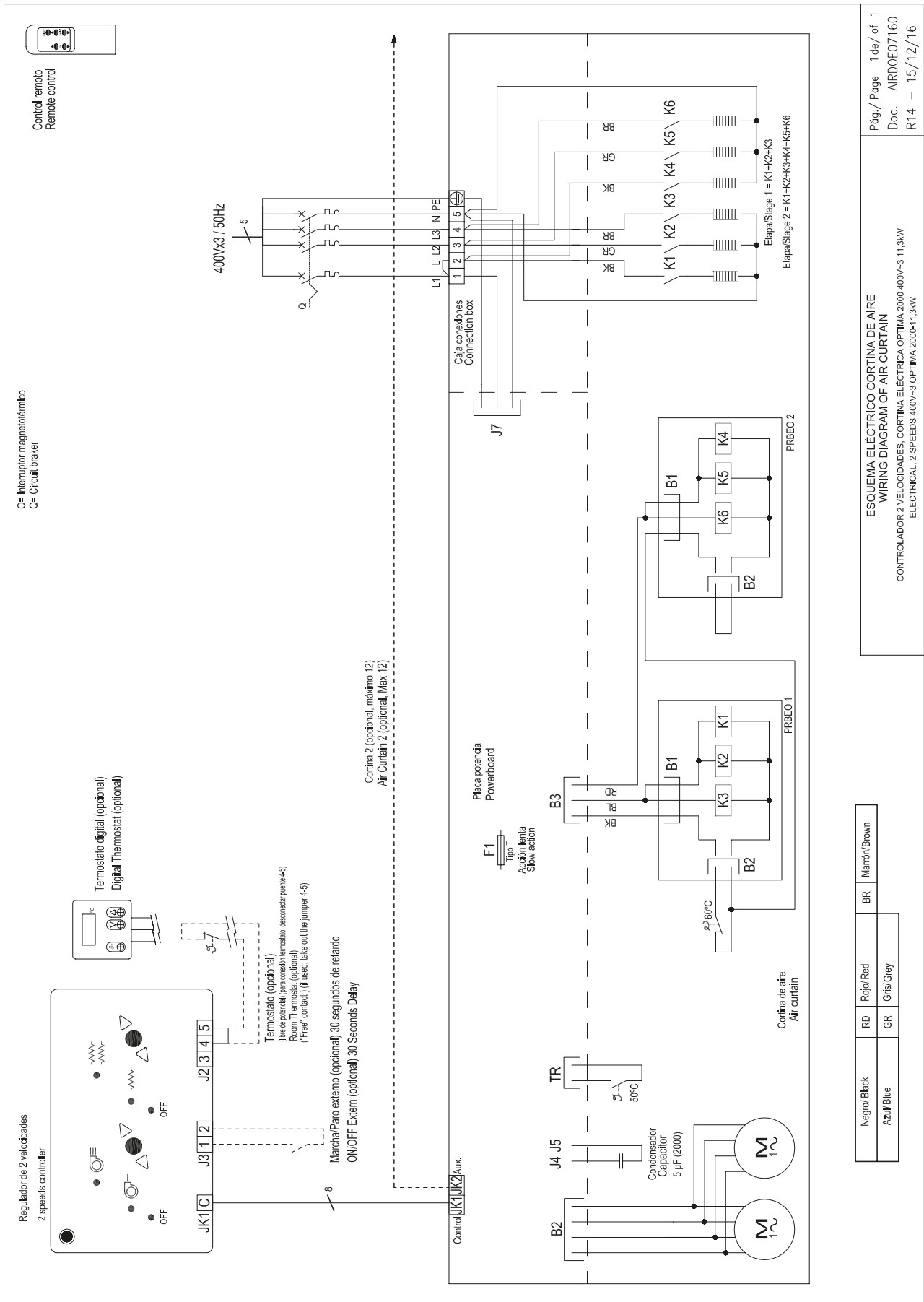

Pág. / Page 1 de / of 1  
Doc. AIRDOE07160  
R14 - 15/12/16

**ESQUEMA ELÉCTRICO CORTINA DE AIRE**  
WIRING DIAGRAM OF AIR CURTAIN  
CONTROLADOR 2 VELOCIDADES, CORTINA ELÉCTRICA OPTIMA 2000 400V~3 11,3kW  
ELECTRICAL 2 SPEEDS 400V~3 OPTIMA 2000-11,3kW

Negro/Black	RD	Rojo/Red	BR	Marrón/Brown
Azul/Blue	GR	Grís/Grey		

In case there is a need to connect the curtain to a PLC, the corresponding diagram is attached.



# DATA SHEET

## Technical Features



Range  
Up to 2,8 m



Airflow / Length  
1700 - 3700 m<sup>3</sup>/h  
1m to 2 m



Fan  
Tangential  
2-speed



Heating type  
E electrical 2 stages  
P water  
A no heating



Heating capacity  
E : 3,8 - 11,3 kW  
P : 10,8- 20,6 kW



Control  
Plug&Play with  
manual regulator and  
remote control



Casing  
Galvanised steel



Inlet grille  
Hexagonal perforated



Outlet lamellas  
Anodised aluminium,  
airfoil type

Standard RAL 9016 / 9006 Stainless steel Other colours on request

The innovative concept of a decorative recessed air curtain for fully visible installation.

It is designed to be integrated into modern premises with contemporary architecture or industrial style. The front panel is ideal for customising with logos, lighting, lettering or signage, according to the customer's requirements.

It incorporates tangential fans with low noise twisted profile turbine, with 2-speed external rotor motor.

Includes a Plug&Play wall-mounted controller with 7m RJ45 cable, plus a remote control. Optionally, it can be regulated with the Clever Advanced Control (programmable, automatic, intelligent, compatible with Modbus RTU for PLC).

### ONLY AIR

Model	Airflow m <sup>3</sup> /h		Ventilation Power 230V W		Ventilation Current 230V A		Noise level (5m) dB	Weight kg
	50Hz	60Hz	50Hz	60Hz	50Hz	60Hz		
	TOP 1000 A	1700	1900	80	109	0,41		
TOP 1500 A	2200	2350	117	145	0,53	0,74	36/51	33
TOP 2000 A	3200	3700	160	218	0,82	1,12	38/53	43,5

### ELECTRICAL HEATING

Model	Airflow m <sup>3</sup> /h		Electrical Heating Power kW	Electrical Heating Voltage	Electrical Heating Current A	Ventilation Power 230V W		Ventilation Current 230V A		Noise Level (5m) dB	Weight kg
	50Hz	60Hz				50Hz	60Hz	50Hz	60Hz		
	TOP 1000 E	1700				1900	4/6	400Vx3	5,8/8,7		
TOP 1000 E-9	1700	1900	6/9	400Vx3	8,7/13	80	109	0,41	0,56	35/50	26
TOP 1000 E230	1700	1900	3,8/5,6	230Vx1	16,5/24,5	80	109	0,41	0,56	35/50	25
TOP 1500 E	2200	2350	6/9	400Vx3	8,7/13	117	145	0,53	0,74	36/51	36,5
TOP 1500 E230-6	2200	2350	3,8/5,6	230Vx1	16,5/24,5	117	145	0,53	0,74	36/51	36,5
TOP 1500 E230-9	2200	2350	6/9	230Vx1(*)	26/39,1	117	145	0,53	0,74	36/51	36,5
TOP 2000 E	3200	3700	5,6/11,3	400Vx3	8,1/16,3	160	218	0,82	1,12	38/53	52,5
TOP 2000 E230	3200	3700	5,6/11,3	230Vx1(*)	24,5/49,1	160	218	0,82	1,12	38/53	52,5

(\*) 2 separate power supply lines

### WATER HEATING

Model	Airflow m <sup>3</sup> /h		Thermal Power 80/60°C kW		Water Pressure Loss 80/60°C Pa		Ventilation Power 230V W		Ventilation Current 230V A		Noise Level (5m) dB	Weight kg
	50Hz	60Hz	50Hz	60Hz	50Hz	60Hz	50Hz	60Hz	50Hz	60Hz		
	TOP 1000 P	1450	1650	8,30	10,13	7360	12120	80	109	0,41		
TOP 1500 P	2175	2250	13	14,80	7480	11050	117	145	0,53	0,74	38/52	36,5
TOP 2000 P	2850	3290	17,10	20,91	6810	11390	160	218	0,82	1,12	40/54	48

# Dimensions

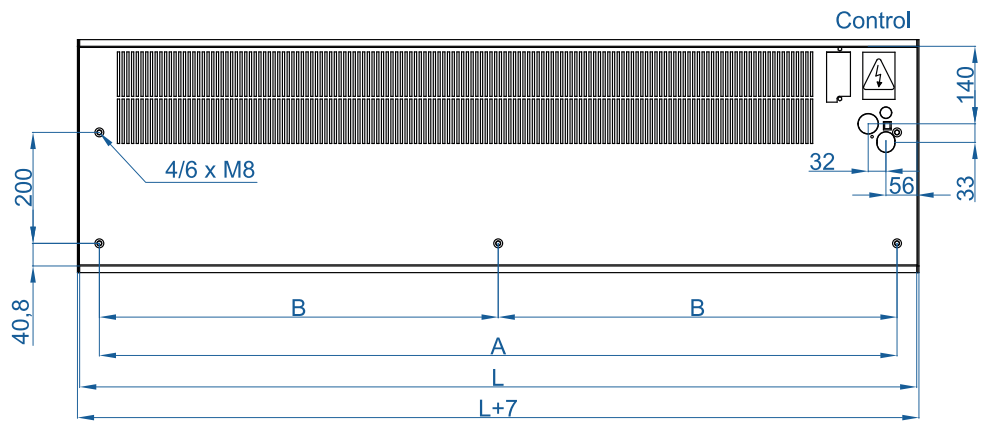
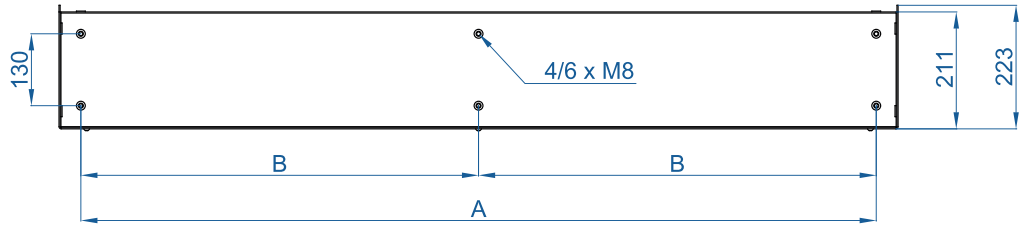
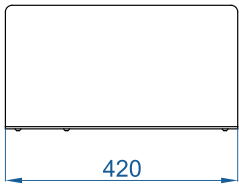
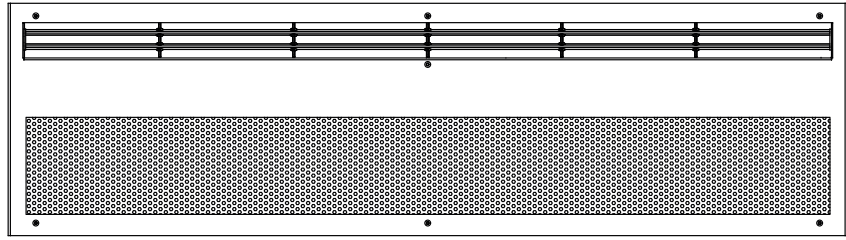





	L	A	B
TOP 1000	1010	938	-
TOP 1500	1510	1438	-
TOP 2000	2010	1938	969

CAD drawings, BIM files, installation manuals and other documentation



## MAINTENANCE INSTRUCTIONS

	<b>For safety, before cleaning, stop the curtain through the controller and disconnect the device from the current.</b>
 	<b>Do not open the service door (risk of electric shock and entrapment in the fans). Repairs must be carried out exclusively by authorized personnel.</b>
	<b>The inside of the device must not be cleaned with water or steam.</b>

### Indicative periodicity of maintenance

N° Action	Action	Frequency
1	Cleaning of the suction grill	Bi-monthly (recommended monthly)
2	Exterior cleaning	Semiannual (recommended quarterly)
3	Interior cleaning	Semiannual (recommended quarterly)
4	Internal inspection	Biannual (recommended annual)
5	Consumption and auditory control	Biannual (recommended annual)
6	Water heating maintenance	Semiannual (recommended quarterly)
7	Electrical heating maintenance	Semiannual (recommended quarterly)

### Inlet grill cleaning

The suction grill prevents the entry of objects into the internal elements. It is a good idea to periodically check that the suction grille is free of any object that could prevent air from entering (plastic bags, paper, etc.). It is recommended to clean the suction grill monthly. In addition, it is important to make sure that the air curtain is off, otherwise the mixture between the dust and a damp cloth would form a paste of dirt that could damage the fan rotor when it sucks in the air or clog the water coil. An annual cleaning of the discharge area must be carried out.



## Exterior cleaning

Wipe the entire outer surface of the air curtain (except the suction grille) with a damp cloth to trap dust particles. In addition to the damp cloth, neutral soaps that do not contain acids or are caustic can be used.



## Interior cleaning

It is recommended to clean the inside of the unit with a vacuum cleaner at least once every 2 years. (\*) It is recommended to clean the inside of the equipment frequently with the help of a vacuum cleaner, especially before the arrival of winter. (\*)

(\*) These periods are indicative depending on the conditions of each installation. In places with a high number of suspended particles, it is desirable to increase the frequency of interior cleaning.



## Internal components visual inspection

Check that the regulation board(s) have not suffered any damage and that they are securely fastened to the equipment frame. Make sure that the board and internal wiring connectors are still well connected. Check that the fans do not move from their mountings and check that the turbines have no impediments to rotate freely (turn it by hand, first turn off the device).

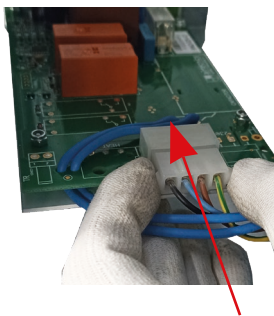

## Air curtain consumption and auditory control checking

Write down the consumption value of the fans that appears on the product label (located on the inside of the service door). Give power to the curtain and with the help of an ammeter, check that the electrical consumption of the curtain at maximum speed is between 110% and 85% of the value indicated on the label. Check that all fans blow air. Keep the curtain at full speed for a few minutes and listen for abnormal noises from the curtain.



## Heating maintenance

To ensure good heat transmission in the air curtain exchanger, it is recommended to check the heating coils as follows:

### Coil cleaning

With both electric coils and water coils, the coil must be cleaned periodically with pressurized air.

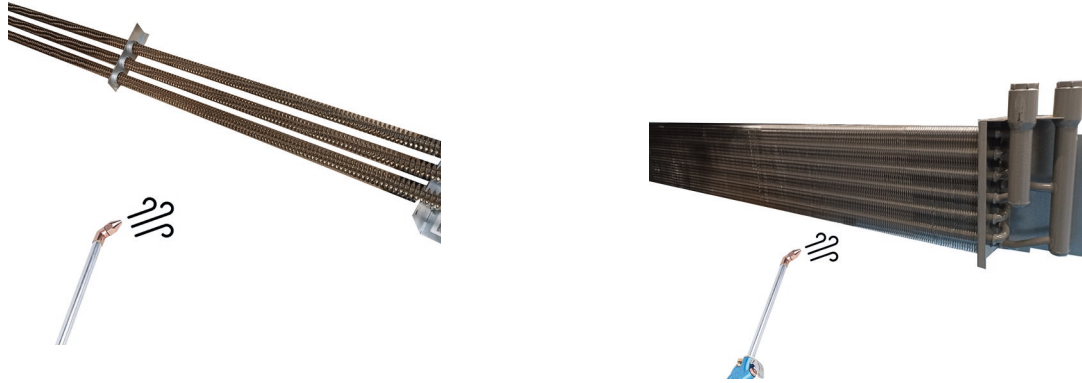

### Water coils

Check the inlets and outlets of the water tubes to ensure that there are no fluid leaks.

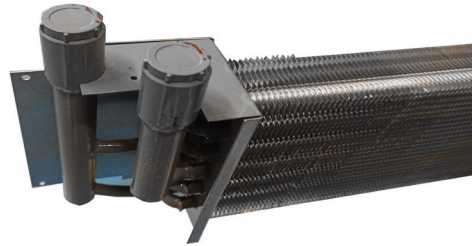

**If a water leak has been detected in the battery, possible corrosion problems in both the battery and the curtain components should be checked.**



## Electrical coil

Check that no cable has been disconnected from the battery circuit:



Resistance type  
for models  
optima in all its  
lengths  
Models

To verify the correct operation of the component, check the battery consumption per heating stage. Theoretical consumptions are shown below:



Curtain size	Heating stage	Air curtain model: TOP			
		Power by measurement and stage (kW)	Theoretical consumption (A) 400Vx3	Power by measurement and stage (kW)	Theoretical consumption (A) 230Vx1
1000	1	2,8	7,4	5,2	15,7
	2	5,65	8,11	7,3	22,1
	1	6	12,7	8,5	25,7
	2	9	12,5	12,3	38,4
1500	1	2,8	7,4	5,8	17,5
	2	5,65	8,11	8	24
	1	6	13,1	8,5	25,7
	2	9	13,3	12,6	38,4
2000	1	5,55	8,13	4,7	14,1
	2	11,3	16,11	9,4	28,2



## REPAIRS AND REPLACEMENTS

**Assembly and electrical connection must be carried out exclusively by specialized professionals and in compliance with these instructions.**

**Before carrying out any repair, it is necessary to:**

	<ul style="list-style-type: none"> <li>• <b>Notify staff and indicate that work is being done.</b></li> <li>• <b>Disconnect the current and protect the circuit breaker.</b></li> </ul>
	<ul style="list-style-type: none"> <li>• <b>Be sure there is no voltage in the unit.</b></li> </ul>
	<ul style="list-style-type: none"> <li>• <b>Be sure the fans have stopped.</b></li> <li>• <b>Use only original spare parts.</b></li> </ul>

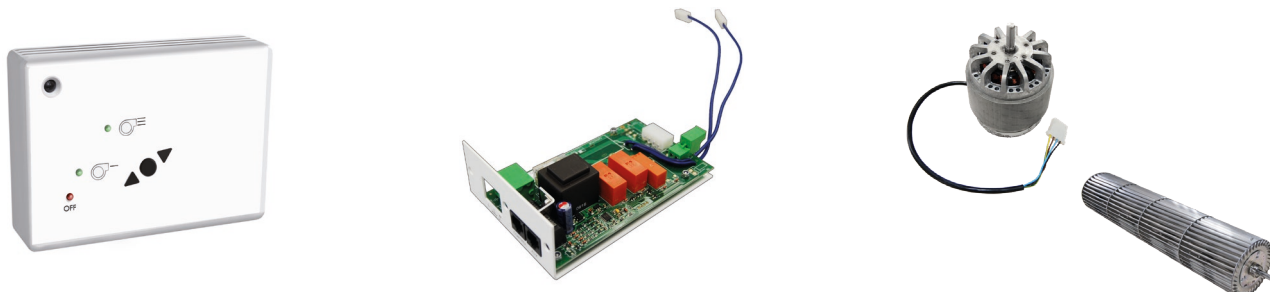

CODE	COMPONENT	COMPONENT REFERENCE	CURTAIN MODEL
AIRCON12052	PCB Optima 2 speed air	AC 2S-E	TOP 1000, 1500 and 2000 air
AIRCON12052	PCB Optima 2 speed electrical	AC 2S-E	TOP 1000, 1500 and 2000 electrical
AIRCON12051	PCB Optima 2 speed water	AC 2S-W	TOP 1000, 1500 and 2000 water
ECOCME06045	Outer rotor motor	4REC35 62Z X22-05	TOP 1000 and 2000
ECOCME06085	Outer rotor motor	4RET45-55S Y18-03	TOP 1500
ECOCME06046	Outer rotor motor	4REC35 J10-A0	TOP 2000
VERCCO33015	Optima air 2 speed regulator IR receptor	CA-2AO-IR	TOP : Air
VERCCO33017	Optima water 2 speed regulator IR receptor	CW-2EV-IR	TOP: Water (P86)
VERCCO33020	Optima electrical 2 speed regulator IR receptor	CE-2AO-IR	TOP: Electrical

## Service door opening

---



1. Remove the service door screws by inserting a screwdriver

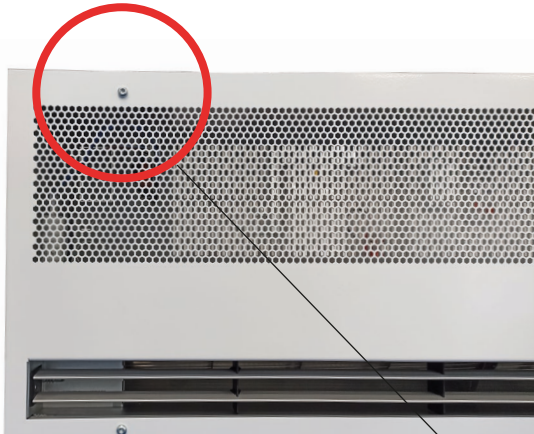

In total 7 screws

2. Open the service panel. with both hands



### Fan replacement

---

Before changing the fan, notify and indicate that it is working, disconnect the power supply, making sure that there is no voltage and that the fans have stopped.

Next, open the grille, identify and release the fan cables. Remove the side (4 screws), unscrew the motor, unscrew the turbine from the shaft and mount the replacement motor following the process in reverse order.

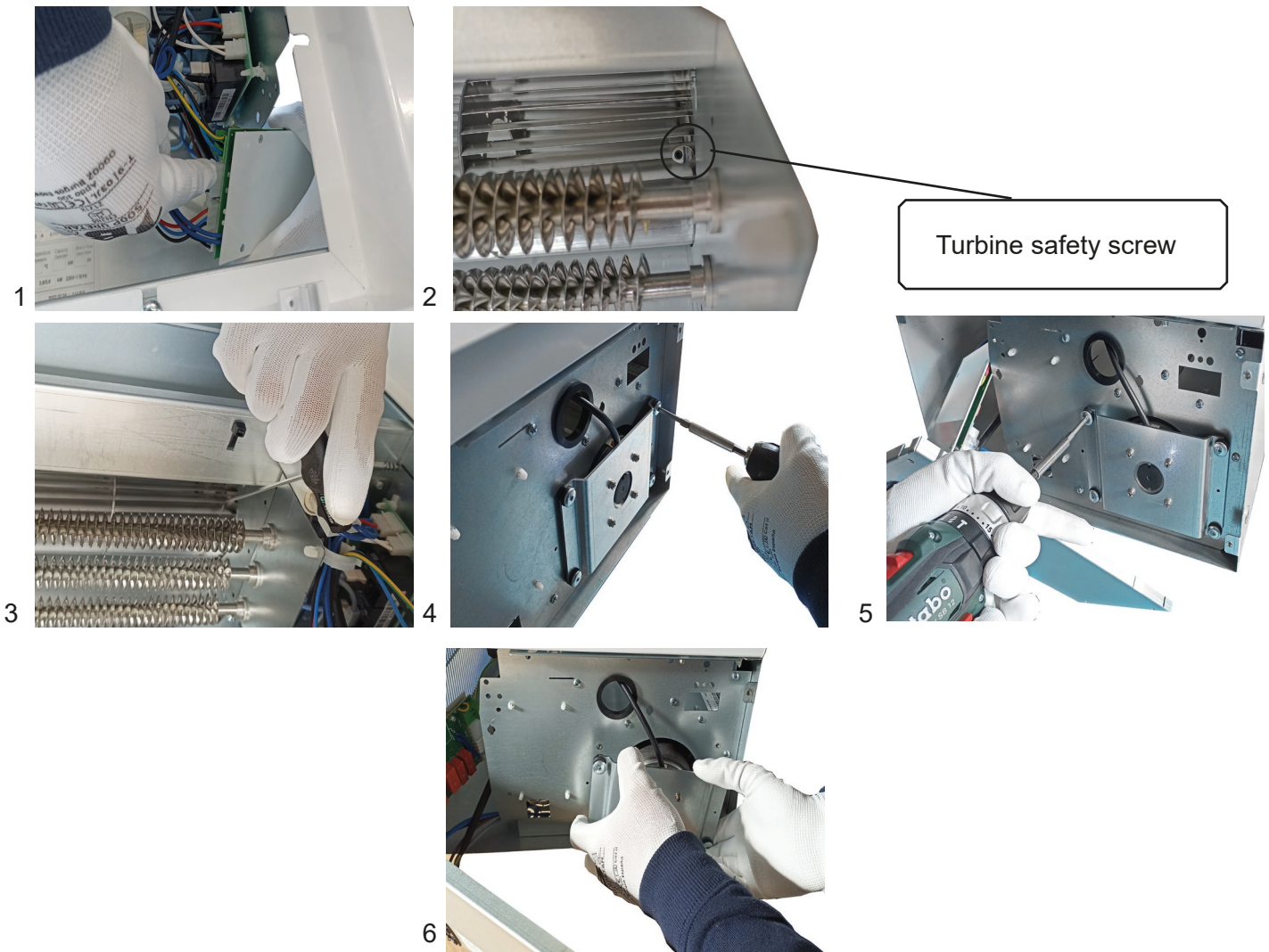

### Replacement of the power board or fuse

Before changing the power board or fuse, notify and indicate that work is being done, disconnect the power supply, make sure that there is no voltage and that the fans have stopped. **Fuse changing:** remove the pcb from the curtain for better maneuverability, remove the fuse protection casing and remove the fuse by hand or with the help of a screwdriver. Proceed to make the replacement and follow the reverse process to leave the curtain functional.

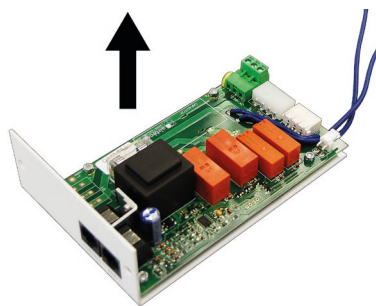

**Power plate change:** open the service door and unscrew the power plate from the inside of the curtain to remove the plate and carry out the necessary repair

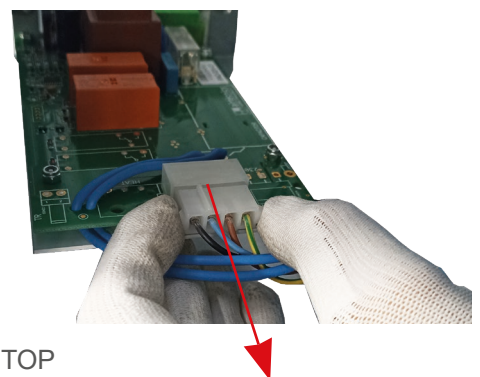
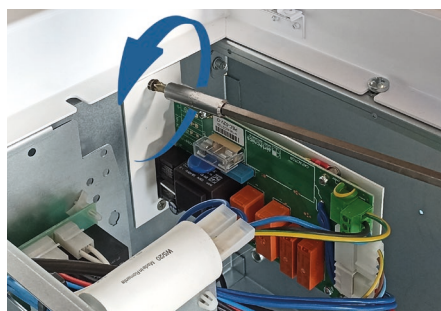

## Recommendation: installation with silentblocks

---

To reduce the sound level and the vibrations of the curtain, it is recommended to carry out an installation with silentblocks:



## Coil replacement

---

**Water coils:** close the building's water inlet and outlet valves up to the air curtain. Open the suction grille and drain the water coil with the drain plug of the main collector as shown in the photograph and disconnect the coil from the installation.

Warning! The curtain is not ready to work in cold mode. Do not circulate cold water through the battery. Before changing the battery, notify and indicate that you are working, disconnect the power supply, make sure that there is no voltage and that the fans have stopped. Before removing the screws that secure the battery:



To remove the battery, unscrew the fixing screws as shown on the next page:



**Electric coil: disconnect the power supply from the battery itself.**

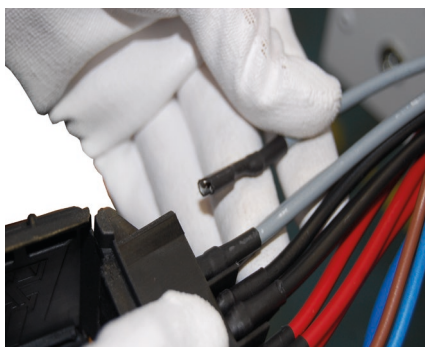
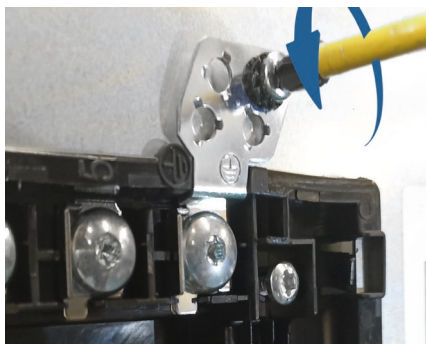
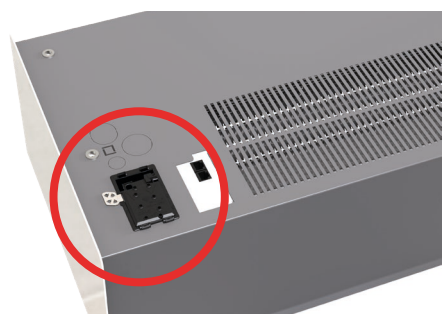

**To remove the battery, unscrew the fixing screws.**



Air curtain size	N° lateral fixing screws
1000	2
1500	2
2000	3

## TROUBLESHOOTING

More than **95% of the claims** occur during the start-up of the equipment and are due to installation errors. Reviewing the following 3 points solves more than 90% of the incidents:

**A) RJ45 cable manipulated:** the cable connecting the control to the air curtain is an 8-way crossover RJ45 cable. If it is manipulated (cut or remove the connector) and spliced backwards, the shade will not work properly and may also damage the electronics. Only re-splicing the connector correctly solves the problem (connection diagram).

**B) RJ45 cable wrong connection.** Check if the position of the connector is correct between “control” or “auxiliary” according to the installation diagram (especially if there is more than one air curtain with a single controller).

**C) Incorrect power supply.** The supply of the air curtain depends on the type of current available and the type of heating of the equipment. Connect following the diagram scheme.

Most commons problems and solutions		
Symptom	Problem	Solution
No light on remote control	Is the RJ45 cable the original without splices or shortening?	Change the cable or reconnect it correctly.
	Does the current reach the connection box?	Correctly connect the terminals of the connection box: Between L and N there must be 230V. If the curtain has a three-phase electric battery, there must be 400V between terminals L1, L2 and L3.
	Is the control connected to the “Control” connector on the board?	Connect the control cable to the “Control” connector on the board (printed circuit), never to the “Aux”.
	Is the fuse on the board in good condition?	Check the fuse and change it if necessary (type T, slow action).
Some lights on the remote control flash	The green maximum speed LED flashes when the curtain stops after having been running with heating	It is not a bug, but a security mechanism. The curtain runs at full speed to cool down and protect components. When it drops below the safety temperature it will stop
	Speed or heating lights flash with the air curtain running	<p>It is a protection mechanism for the curtain so that the internal components are not damaged.</p> <p>Situations in which the problem is continually repeated and how to avoid them:</p> <ol style="list-style-type: none"> <li>1. Clogged suction grille (dirt, objects...) the temperature of the air inside the equipment can increase a lot if it does not circulate correctly. Keep the fence clean.</li> <li>2. Small room size: it is recommended to install a thermostat to regulate the heating power without the protection being activated.</li> <li>3. If the ambient temperature of the room is high, it is recommended to lower the heating power or install a thermostat</li> <li>4. Suction of already hot air coming from a heating equipment outside the air curtain. Move the curtain away, put a thermostat on the suction or lower the heating power.</li> <li>5. Some motor does not work: notify the technical service.</li> </ol>
The heating does not work	Does the triphasic current reach the connection box?	Check installation.
The speed and/or the heating vary constantly for no apparent reason but the control lights do not flash	Surely the telephone type cable passes near sources of interference, emitters, cable trays, especially those that feed motors, etc.	Run the cable as far away as possible from sources of interference (especially on long runs) or use a shielded cable

## ACCESSORIES



### Clever Control

Smart proactive regulation, advanced functions, automatic/manual operation, door delay, time programmer, energy saving modes, multi-device management, BMS Modbus connection, etc.



### External temperature probe

Allows you to take the temperature in a different place than the one the regulator is.



### Interface II

Allows connection to a centralized management system (BMS, PLC, etc).



### 2 speed Hand Auto (water coil)

It allows to connect antifreeze sensor, door contact, room thermostat.



### Digital thermostat

It allows to modify the heating stages and/or the speed of the air depending on the temperature and the chosen program



### Ambient Thermostat

Limits heating operation to the selected temperature.

Supports, feets, silentblocks, etc. (depending on model).

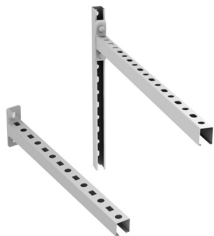

Door contact, thermostatic valve, solenoid valve, antifreeze sensor, etc..

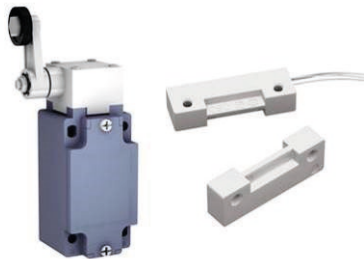

RJ45 cable 20m y 50m.



## DECLARATION OF CONFORMITY



Declaration **CE** of conformity / Declaración **CE** de conformidad

Manufacturer **Motors i Ventiladors S.L. (AIRTÈCNICS)**  
Fabricante **Conca de Barberà 6, Pol. Ind. Pla de la Bruguera**  
**08211 Castellar del Vallès (Barcelona) Spain**

We declare, under our sole responsibility, that the product  
*Declaramos, bajo nuestra única responsabilidad, que el producto*

**Air Curtains**  
**Cortinas de aire**

with models / *con los modelos*

**Minibel, Optima, Recessed Optima, Optima Wireless, Recessed Optima Wireless, Optima K, Top, Recessed Compact, Aris, Windbox, Recessed Windbox, Smart, Dam, Recessed Dam, Deco, Kool, Rund, Invisair, Rotowind, Variwind, Zen, Max, Maxwell, Compact Fly, Fly K, Fly KL-KXL, Fly KBB, Windbox BB, Recessed Windbox BB, Zen BB, Windbox L-XL, Duojet, Triojet System.**

is/are developed, designed and manufactured in accordance with the following directive(s)  
*ha(n) sido desarrollado(s), diseñado(s) y fabricado(s) de acuerdo con la(s) siguiente(s) directiva(s)*

**Low Voltage Directive 2014/35/EU**  
**Directiva Baja Tensión 2014/35/UE**

**Electromagnetic Compatibility Directive 2014/30/EU**  
**Directiva Compatibilidad Electromagnética 2014/30/UE**

**Restriction Certain Hazardous Substances Directive 2011/65/EU (RoHS)**  
**Directiva Restricción Substancias Peligrosas 2011/65/UE**

**Eco-design Energy-related Products Directive 2009/125/EC**  
**Directiva Diseño Ecológico Productos Con Energía 2009/125/CE**

applying the following harmonized standards in particular  
*aplicando las siguientes normas armonizadas en particular*

**LVD: EN 60335-1:2012 + AC:2014 + A11:2014 + A13:2017 + A1:2019 + A:14:2019 + A2:2019**  
**EN 60335-2-30:2009 + A11:2012 + A1:2020 + A12:2020**

**EMC: EN 61000-3-11:2000**  
**EN 61000-3-12:2011**  
**EN 55014-1:2017 + A11:2020**  
**EN 55014-2:2015**  
**EN 62233:2008 + AC:2008**

**RoHS: EN 50581:2012**

Date / Fecha  
Name / Nombre  
Position / Cargo

**15/05/2023**  
**Jordi Hierro**  
**Technical Manager / Director Técnico**

**MOTORS I VENTILADORS, S.L.**  
ESB58967183 - C/ Conca de Barberà, 6  
08211 Castellar del Vallès  
Tel. 937159988 - Fax 937159989

**UK  
CA**

## UK Declaration of conformity

Manufacturer **Motors i Ventiladors S.L. (AIRTÈCNICS)**  
**Conca de Barberà 6, Pol. Ind. Pla de la Bruguera**  
**08211 Castellar del Vallès (Barcelona) Spain**

We declare, under our sole responsibility, that the product

**Air Curtains**

with models

**Minibel, Optima, Recessed Optima, Optima Wireless, Recessed Optima Wireless, Optima K, Top, Recessed Compact, Aris, Windbox, Recessed Windbox, Smart, Dam, Recessed Dam, Deco, Kool, Rund, Invisair, Rotowind, Variwind, Zen, Max, Maxwell, Compact Fly, Fly K, Fly KL-KXL, Fly KBB, Windbox BB, Recessed Windbox BB, Zen BB, Windbox L-XL, Duojet, Triojet System.**

is/are developed, designed and manufactured in accordance with the following regulation(s)

**Electrical Equipment (Safety) Regulations 2016 No. 1101**

**Electromagnetic Compatibility Regulations 2016 No. 1091**

**The Restriction of the Use of Certain Hazardous Substances in Electrical and Electronic Equipment Regulations 2012 No. 3032**

**The Ecodesign for Energy-Related Products and Energy Information (Amendment) (EU Exit) Regulations 2019 No. 539**

applying the following harmonized standards in particular

**LVD: BS EN 60335-1:2012+A2:2019**  
**BS EN 60335-2-30:2009+A12:2020**

**EMC: BS EN IEC 61000-3-11:2019**  
**BS EN 61000-3-12:2011**  
**BS EN IEC 55014-1:2021**  
**BS EN IEC 55014-2:2021**

**RoHS: BS EN IEC 63000:2018**

Date  
Name  
Position

**15/05/2023**  
**Jordi Hierro**  
**Technical Manager**



**MOTORS I VENTILADORS, S.L.**  
ESB58967183 - C/ Conca de Barberà, 6  
08211 Castellar del Vallès  
Tel. 937159988 - Fax 937159989

## IDENTIFICATOR



Model <small>Modelo</small>	WINDBOX M 2000 P86		
Airflow <small>Caudal</small>	3320	m3/h	
Blowers <small>Ventiladores</small>	3,8 A	0,856 kW	230 V/50Hz
<b>Heating</b>			
<small>Calefacción</small>	<small>Temperatura</small>	<small>Capacidad</small>	<small>Water Flow</small> <small>Caudal Agua</small>
Water Coil <small>Bateria Agua</small>	80/60 °C	20,65 kW	900 l/h
Electric Heater <small>Bateria Eléctrica</small>	kW		
Serial Number <small>Número de Serie</small>	2022 01 21 / 113.864		

Each air curtain is identified by a unique serial number printed in a label located inside the door service. There is also indicated the model and their technical characteristics (flow, fans technical characteristics and power heating).

It is indispensable to have this number to facilitate possible replacements or technical information of the air curtain in question.



AIRCOR15698 113864

WINDBOX M 2000 P86      www.airtecnics.com

## GUARANTEE

Your air curtain is guaranteed for a period of one year from the date of purchase. We will adjust, repair or replace at our discretion from our warehouse any defect, system failure or part found to be defective. The assembly cost out of our warehouse is at buyer expense. The products that, in our eyes, have been inadequately used, incorrectly manipulated, improperly installed, connected to different nominal tensions, modified, repaired by non-authorized workers or that have suffered damages during transport are totally excluded from the guarantee.

*To validate the guarantee it should be correctly filled and enclosed with the invoice that vouches for the buying date. If it is manipulated, it will lose all validity.*

*It is the buyer's responsibility to take the necessary safety measures because in case of a failure or mistake in one of our products, no damages to third parties, sets or installations will occur.*

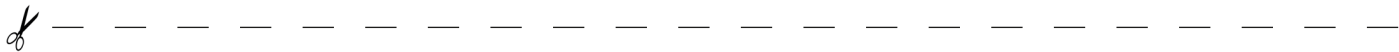

### Guarantee draft

**Air curtains data:**

Model: ..... Series number: .....

Invoice date: ..... Invoice number: .....

**Buyer data:**

Name: .....

Address: .....

Country: ..... Phone: ..... Mail: .....

**Seller data:**

Name: .....

Address: .....

Country: ..... Phone: ..... Mail: .....

**Buyer signature and stamp**

**Seller signature and stamp**

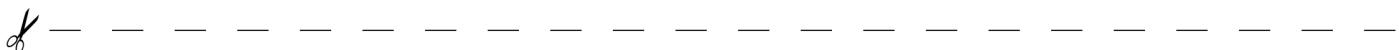

*If you detect some error in this manual, we'll be pleased to receive your feedback, it helps us to improve even more. Airtécnicos reserves the right to modify some of the specifications in this manual*

Conca de Barberà, 6 - Pol. Ind. Pla de la Bruguera  
E-08211 Castellar del Vallès (Barcelona) Spain  
☎ + 34 93 715 99 88  
airtecnicos@airtecnicos.com

**[www.airtecnicos.com](http://www.airtecnicos.com)**



AIRDOM05525-R1(06/23)

*Airtècnics reserves the right to modify some of the specifications in this manual.*