

Air curtain: Aris



INSTALLATION, OPERATION AND MAINTENANCE MANUAL



*Please, read these instructions carefully before attempting installation
Deliver this manual to the final user.*

SAFETY WARNING SYMBOLS



!Attention, Danger, Safety Advice!



⚡ Danger from electric current or high voltage!



⚠ Injuries risk!



⚖ Danger! Do not stay underneath: Heavy load.



i Important information.

INDEX

INSTALATION	4
Regulator and board	8
Water heating	9
TRANSPORTATION AND STORAGE	10
OPERATING INSTRUCTIONS.....	10
Characteristics of regulation boards.....	10
Common characteristics to all regulators	10
ELECTRICAL SQUEMES	14
DATA SHEET	25
MAINTENANCE INSTRUCTIONS	27
REPAIRS AND REPLACEMENTS	31
FAULTS AND SOLUTIONS	36
DECLARATION OF CONFORMITY	37
IDENTIFICATOR	39
GUARANTEE	39

INSTALLATION

Tips and recommendations for a good installation

LENGTH

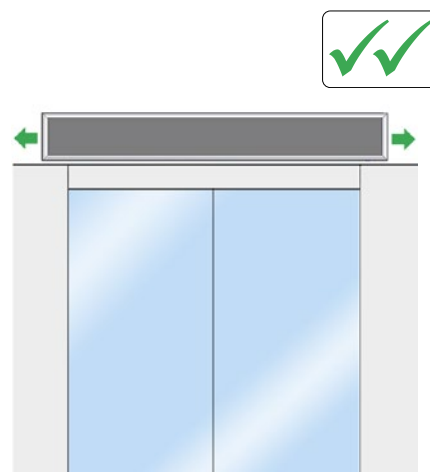
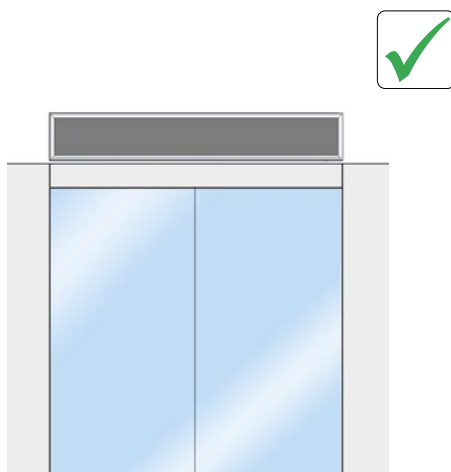
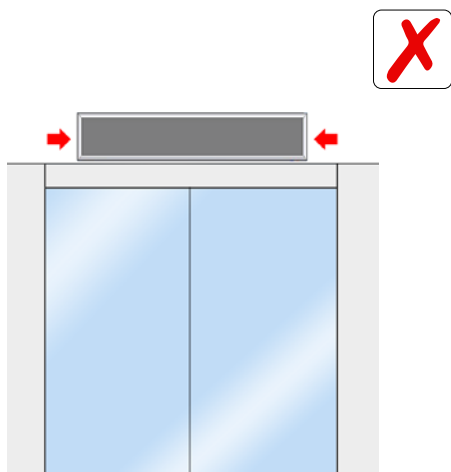

CENTERED / HEIGHT

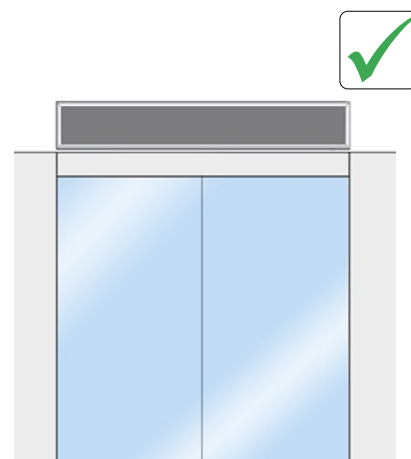
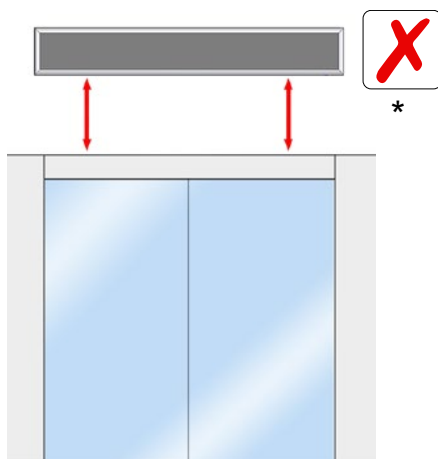
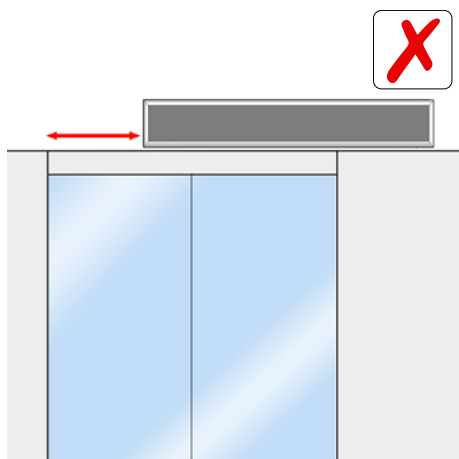

(*) Unless it has been designed to be installed at that height.

DOOR DISTANCE

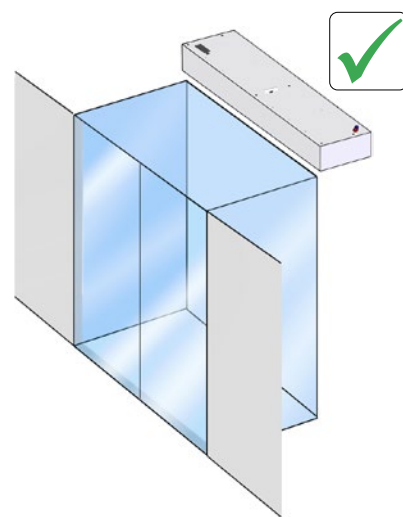
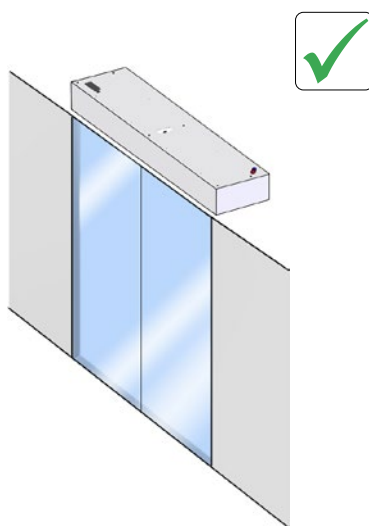
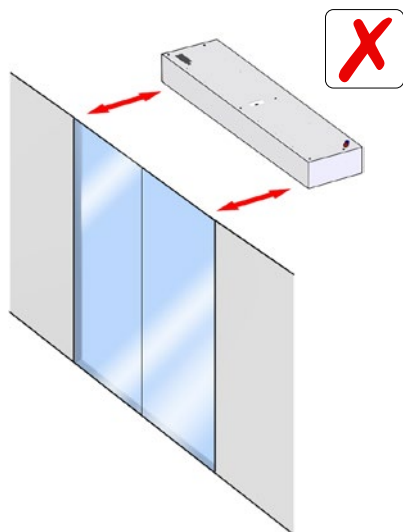

AIR DISCHARGE

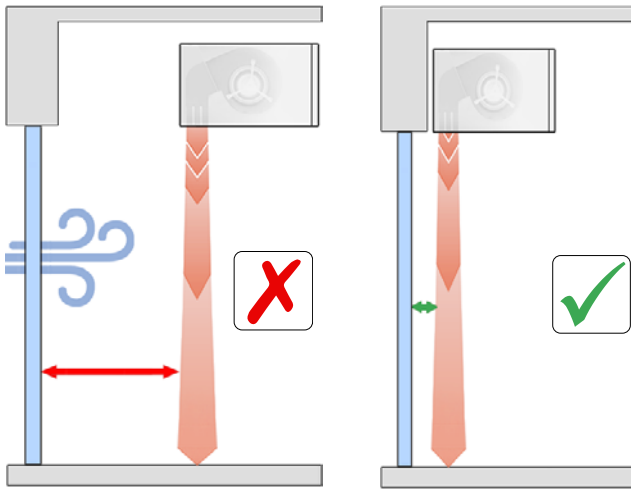



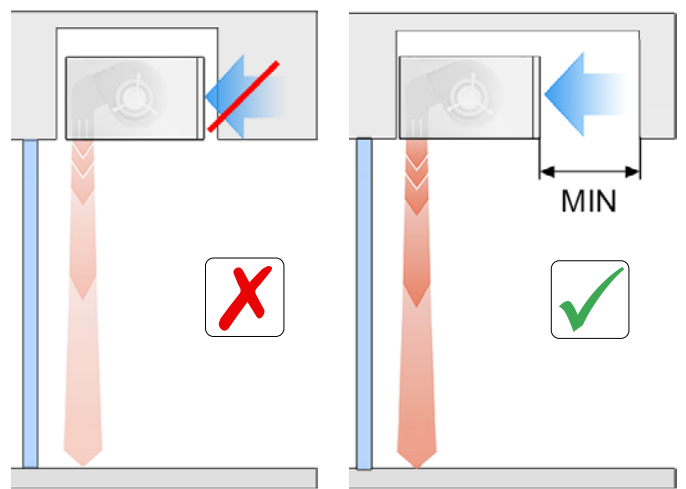

AIR ASPIRATION

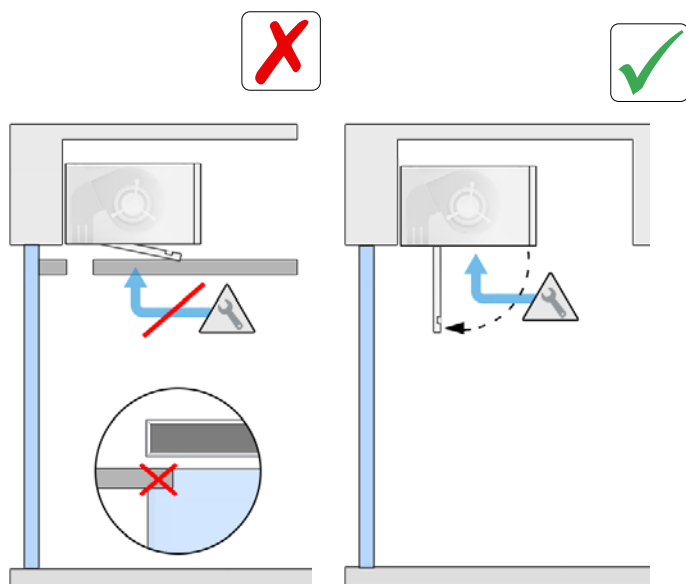

MAINTENANCE ACCESSIBILITY



Aris model

	<p>Installation work, connection, disconnection, electrical wiring, maintenance and service must be done by qualified people observing these instructions and in accordance with all applicable norms and standards. If the unit is operated with additional controller, please consider its specific instructions.</p>
	<p>For manipulation safety, being it assembling, transport or maintenance duties it's a must to wear the correct individual protection equipment recommended. Those being gloves, insulating shoes, goggles and helmet.</p>
	<p>There is no need to open the service door to connect the air curtain. All connections of power supply, control, water pipes (when the model is a water heated) and fixations are external. They are placed on top of the units. Depending of the model, inside of them may be auxiliar connectors like temperature sensors, electrovalves, etc.</p>
	<p>For safety, the air curtains never have to be stopped by disconnecting them from the main supply, always through the controller and waiting 10 minutes at least to disconnect the main supply. In case to not follow these instructions, the internal parts of the air curtain can be damaged.</p>

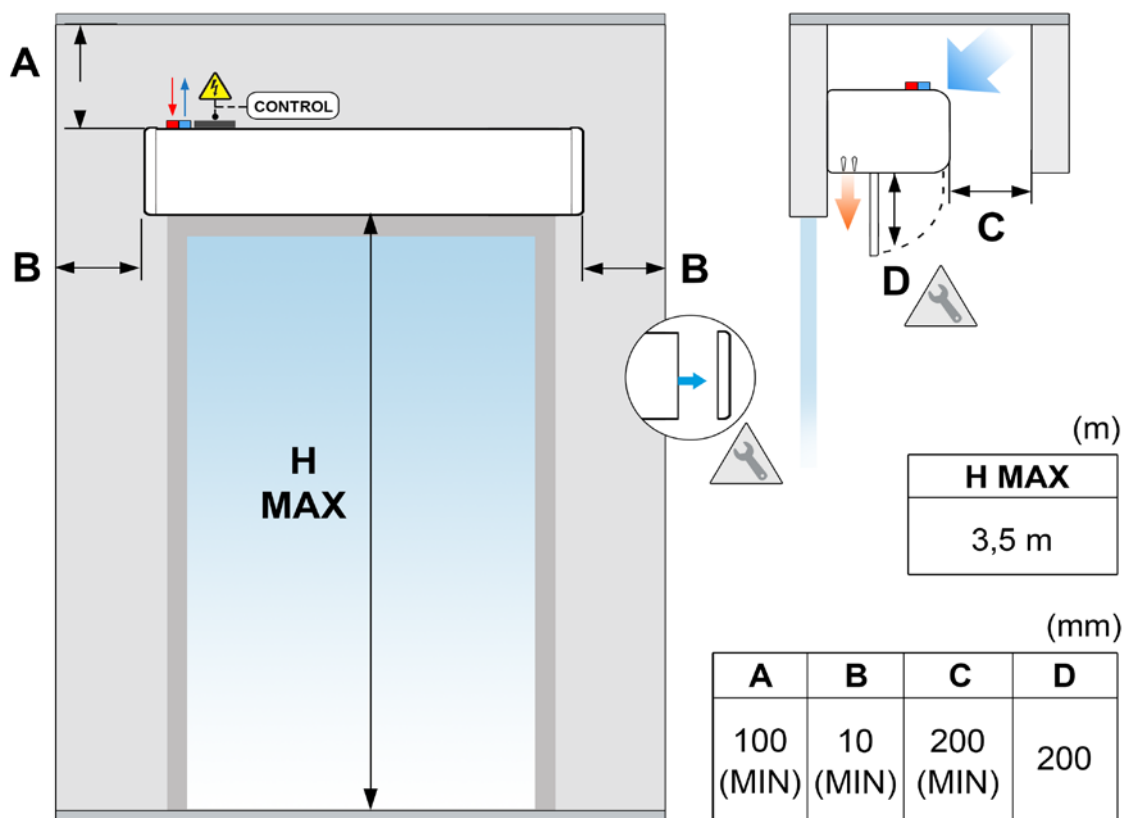

H MAX. Maximum recommended range, MIN. Recommended minimum distance.

The minimum recommended distance between the suction grille and any obstacle is 200 mm (Dimension C)

Dimension D: service opening distance.

Connection diagram

Standard without heating, with water and electric heating 400V x 3 and 230Vx1

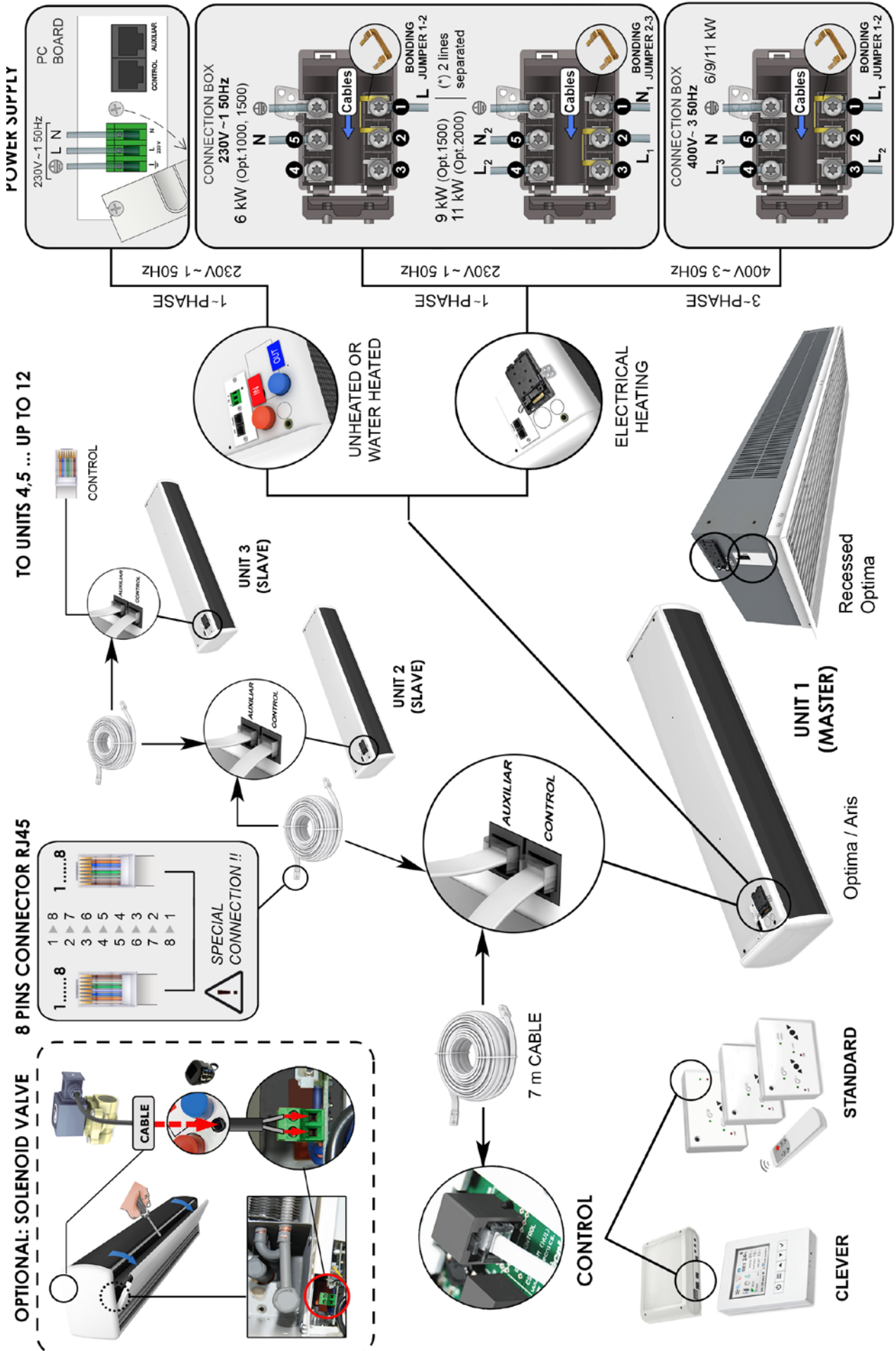

Power supply

To connect power to the device, there is a black junction box at the exterior top of the air curtain.



Water coil models:

For curtains without heating or with water heating, only the curtain must be connected to single-phase current at 230V for the operation of the fans directly to the PCB.

Electrical coil models:

In the case of a curtain with an electric battery, connect a 400Vx3 three-phase power supply or a single-phase 230Vx1 power supply from the electric battery. Optionally, the battery power can be 230Vx3 triphasic (special diagram included). The single-phase current is only connected to one phase of the three-phase lines, plus a connection to the neutral (400 V).

Recommended maximum number of curtains connected to the same differential:

Model	Differential 30mA	Differential 300mA
OPT / RO / OPT W / RO W / Aris	20 uds.	20 uds.

Each installation must be reviewed by a specialist to ensure that there is no incompatibility with the selected differential and the connected curtains.

Regulator and board

To connect the controller to the curtain, there is a connector located on the outside top of the air curtain. It is not necessary to open the curtain to connect it, except for internal connections. Use the 7 meter RJ45 cable supplied with the equipment. The communication between the controller and the board is digital and low voltage.



Fixings

The curtain has several external fastening points depending on the weight and length (see situation in the model characteristics section).

Generally, air curtains are installed horizontally. For vertical installation, use the feet kit (see accessories section). The anchor must be sized according to the weights of each curtain indicated on the technical data page. The installation can be done using threaded rods, tensioners or other supports (see available supports in the accessories section).

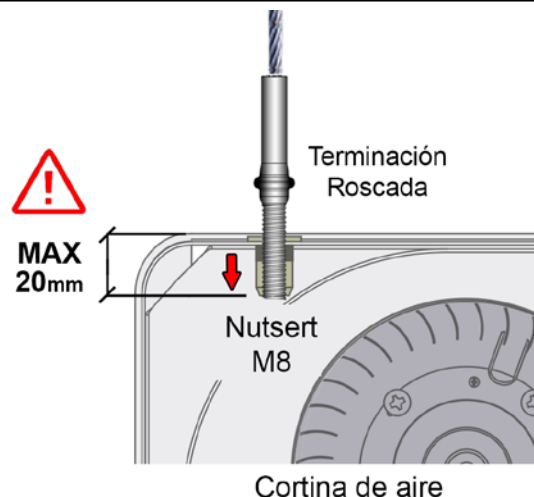

Water heating

The air curtains with water coil have a 230Vx1 output to optionally connect a solenoid valve (it opens or closes the water inlet to the heat exchanger of the coil). This outlet can also be used for other low amperage electrical appliances (10A).



Recomendations:

- Close the hot water circulation (valve) to avoid overheating of the motors while the equipment is off. Optionally, we have solenoid valves.
- In the installation of the building, two shut-off valves (outflow and return) should be provided to be able to disassemble the equipment without problems.
- Mount a purge valve at the highest point of the heating section.

The ambient temperature must always be higher than +4° C. Otherwise, the equipment must be provided with a frost protection device (antifreeze sensor).

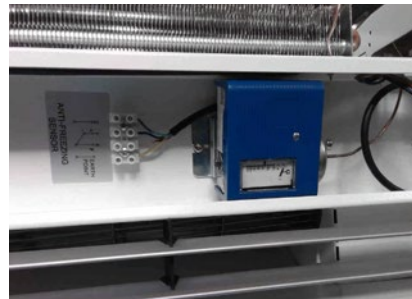

The water batteries have a drain screw in the collector area.

Electric heating

The electric battery has three or six bar-shaped resistances (depending on the model) that, combined with each other, provide three heating stages. The regulation is carried out by one or two PRBEO (depending on the model) up to 18kW included.

All the batteries are electrically and electronically protected against overheating.

During the first uses, the electric battery can give off some odor that disappears in a few days.

According to battery power, the regulation is carried out by:



Size of the air curtain	Heater power (kW)	Regulation type
1000	9	1 PRBEO
1500	12	2 PRBEO
2000	18	2 PRBEO

TRANSPORTATION AND STORAGE



Warning! Heavy load.
Do not stand under the suspended load during transportation or assembly.

Store in a dry place protected from the environment. If the package is opened, cover the curtain to protect it from the dust. Do not step on or place heavy loads on it to avoid damage to the material. Storage temperature between -20 °C and +40 °C.

When transporting the material, you must ensure that it is not damaged by the forklift. (possible penetration of the fork in the packaging). Observe the instructions on the packaging for correct manipulation of the product.



OPERATING INSTRUCTIONS



For safety, the air curtains must never be stopped by disconnecting the current, always do it through the controller. If the power is turned off to turn off the shade, or within ten minutes of turning it off with the controller, internal components may be damaged.

Characteristics of regulation boards

The air speed is regulated by:

- The changing of the capacitor in the motor.

Common characteristics to all regulators

There are various regulator models depending on the customer's needs: timers, antifreeze detectors, thermostats, etc.

- 2 fan speeds.

- Memory: guarantees that, in the event of a power outage, the selected speed is maintained when service is restored. This function can be activated/deactivated using the ON/OFF switch located inside the regulator.



- **RJ45 cable and digital communication:** they have a fast connection with a telephone type cable and digital communication between the regulator and the curtain. This type of communication is reliable even over long distances (up to 20 meters).

- **External start-stop:** inside the regulator there is the possibility of connecting a normally open contact (1,2) that governs the on/off of the equipment through any external device. The contact is potential free. When the contact is closed, the curtain has a 30-second delay before stopping. It can be used for a timer, temperature sensor, fire alarm, PLC, etc.



- **Remote control:** all standard dimmers have an IR receiver that allows them to use a remote control.

Common Features of water coil Curtain Controllers

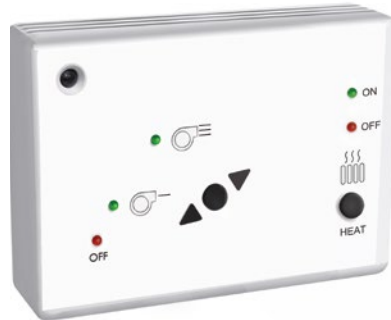

Controller for curtains with water coil

- **Heating ON/OFF:** with the “HEAT” ON/OFF button you manually activate or deactivate the 230Vx1 power supply to the solenoid valve to open or close the passage of water to the coil. This 230x1V output is located in the upper part of the unit, next to the regulator’s RJ45 cable connection.
- **External thermostat (electrovalve control):** If you want to control the water inlet to the coil by means of a thermostat, the thermostat must be installed in series with the solenoid valve. In this way, when the set temperature is reached, the solenoid valve closes the passage of water.
- **Safety thermostat:** in the event that the internal temperature reaches 60°C and is not selected the maximum speed of the curtain, automatically the speed of ventilation increases 1 speed every 2 minutes to evacuate the excess thermal energy from the interior. It will continue at maximum speed until the interior temperature drops below 50°C.

Safety operation is indicated by a flashing LED. If safety is activated usual way you have to find out the cause. Most likely you will need to increase the frequency of cleaning the suction grille.

For example, an obstruction in the suction grille, the motor stopped, a temperature high ambient temperature in an installation without a room thermostat, etc., would cause the curtain to speed up automatically.

It also prevents the air expelled by the curtain from exceeding 60°C (sensing temperature excessive for people).

Characteristics common to all controllers for electric battery

System with 2 ventilation speeds and 2 heating stages (C1, C2).



2 heating power:

- 1000 / 1500 air curtain size: C1=2/3 C2 = 3/3 or 1
- 2000 air curtain size: C1= 1/1 C2=2/2 or 1

Limited heating: for safety reasons of the device, the references 1000 of 9kW have the heating power limited by the ventilation speed that we have selected, as follows:

Selected speed	Heating stage
V1	1st heating stage
V2	2nd heating stage

To apply this limitation, the jumper from JP1 of the control is removed at the factory.

In the rest of the references, any air speed can be selected with any heating power.

Furthermore, for equipment safety reasons, the heating does not work if some fan speed is not running. Warning: If the ambient air temperature is high and we set the curtain to maximum heating and minimum ventilation, the electronic security will be activated repeatedly.



Delay thermostat: when the device is stopped with the heating on, there is an increase in temperature inside it that could damage its components due to the thermal inertia of the electrical resistors. To avoid this, the curtain continues to work up to 90 seconds after stopping; and if when stopping the curtain, the temperature rises above 50 °C, the equipment goes to maximum speed and does not stop until the excess thermal energy is evacuated.

Safety thermostat: when the curtain works with heating and the internal temperature rises above 60°C, the safety function is activated: it increases 1 air speed every two minutes until reaching the maximum speed. Then, it starts down 1 stage of heating until it stops. If it persists, after two minutes, it blocks the heating. To unlock it you have to remove the current from the curtain. If at any time the internal temperature does not reach the limit of 60 °C and a downward trend begins, this process is interrupted and returns to normal.

A delay in cleaning the suction grille or a high ambient temperature could temporarily activate this function.

Room thermostat: the curtain is equipped with the necessary contacts to be able to install, if desired, a room thermostat that stops the heating when the set temperature is reached. It is recommended when the equipment is installed in a closed area of reduced dimensions. If you install the room thermostat, remove the jumper between terminals 4 and 5 of the controller and connect the thermostat there.

The air speed and heating stage are indicated by a continuously lit LED, while the safety speed is indicated by a flashing LED. The heating lockout is indicated by its OFF LED flashing at a faster rate.

Special regulators

If there is a need to be able to control more parameters (intelligent proactive regulation, automatic/manual operation, door delay, time programmer, energy saving mode, multi-device management and BMS Modbus connection, among others)), there are two controllers that allow much more possibilities than the standard controller, especially the Clever. The following regulators have their own manual:

- Hand Auto
- Clever control

Remote Control Features

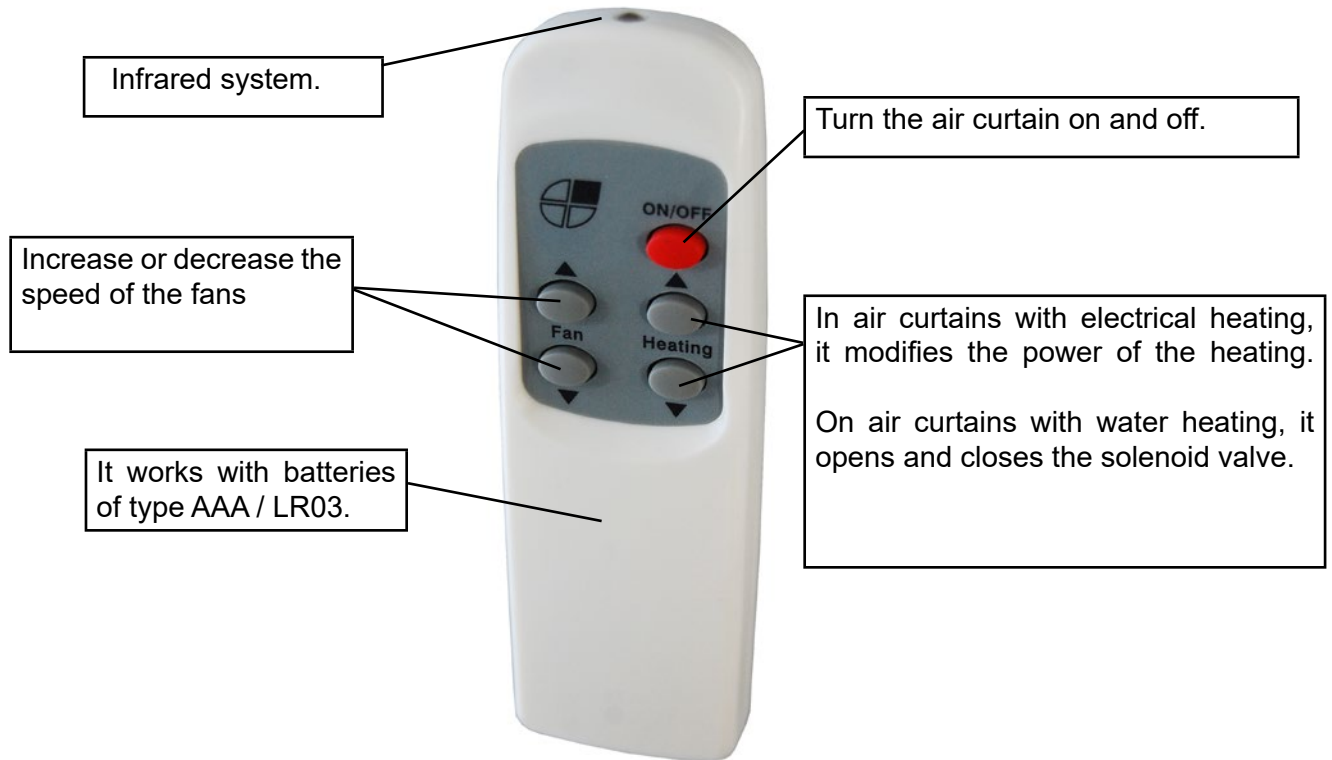

ELECTRICAL SQUEMES

Curtain with water battery or without battery with standard control models 1000 and 1500. Diagram AIRDOE07050s

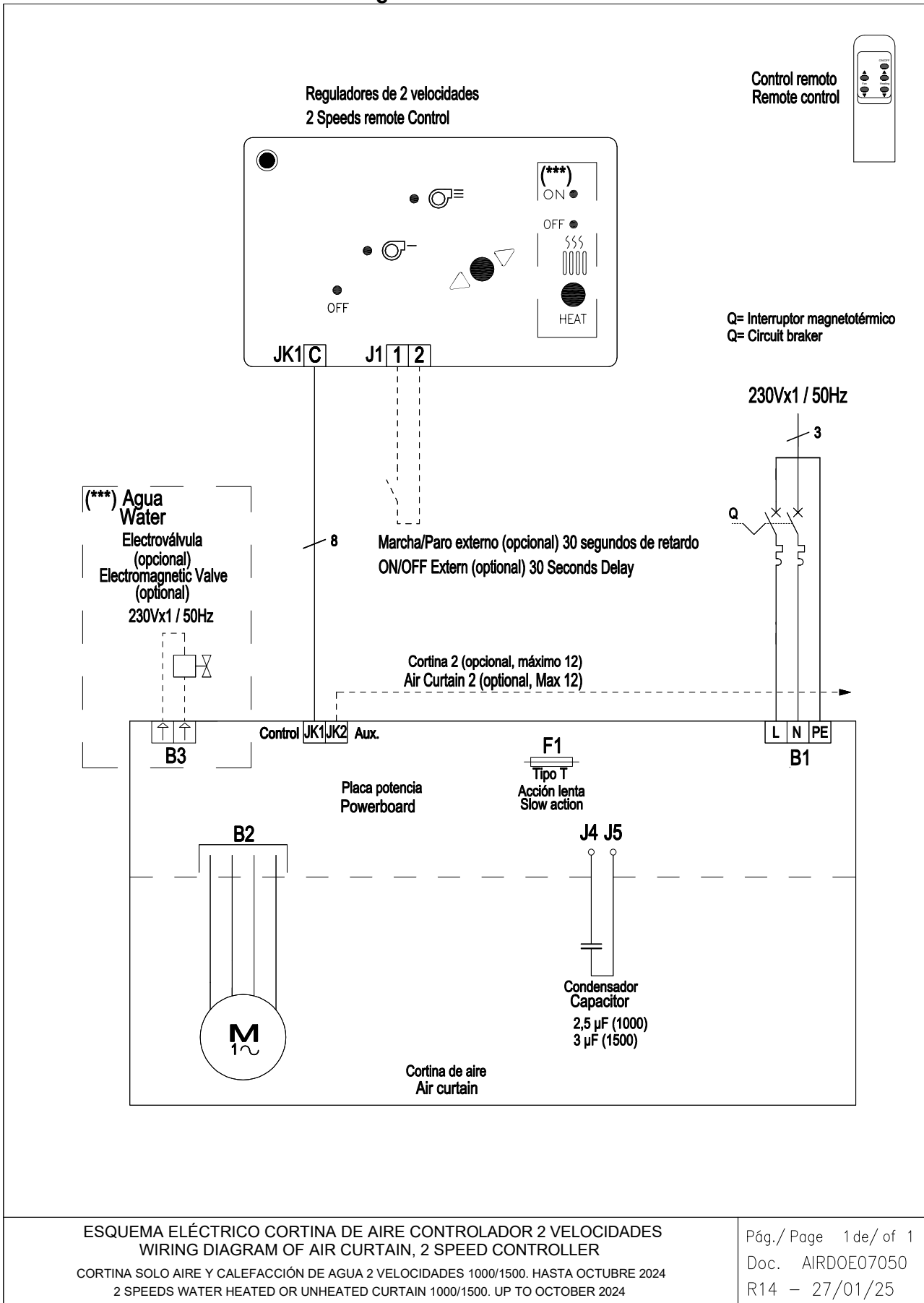

In case there is a need to connect the curtain to a PLC, the corresponding diagram is attached.

Curtain with water battery or without battery with Hand Auto. Diagram AIRDOE07060

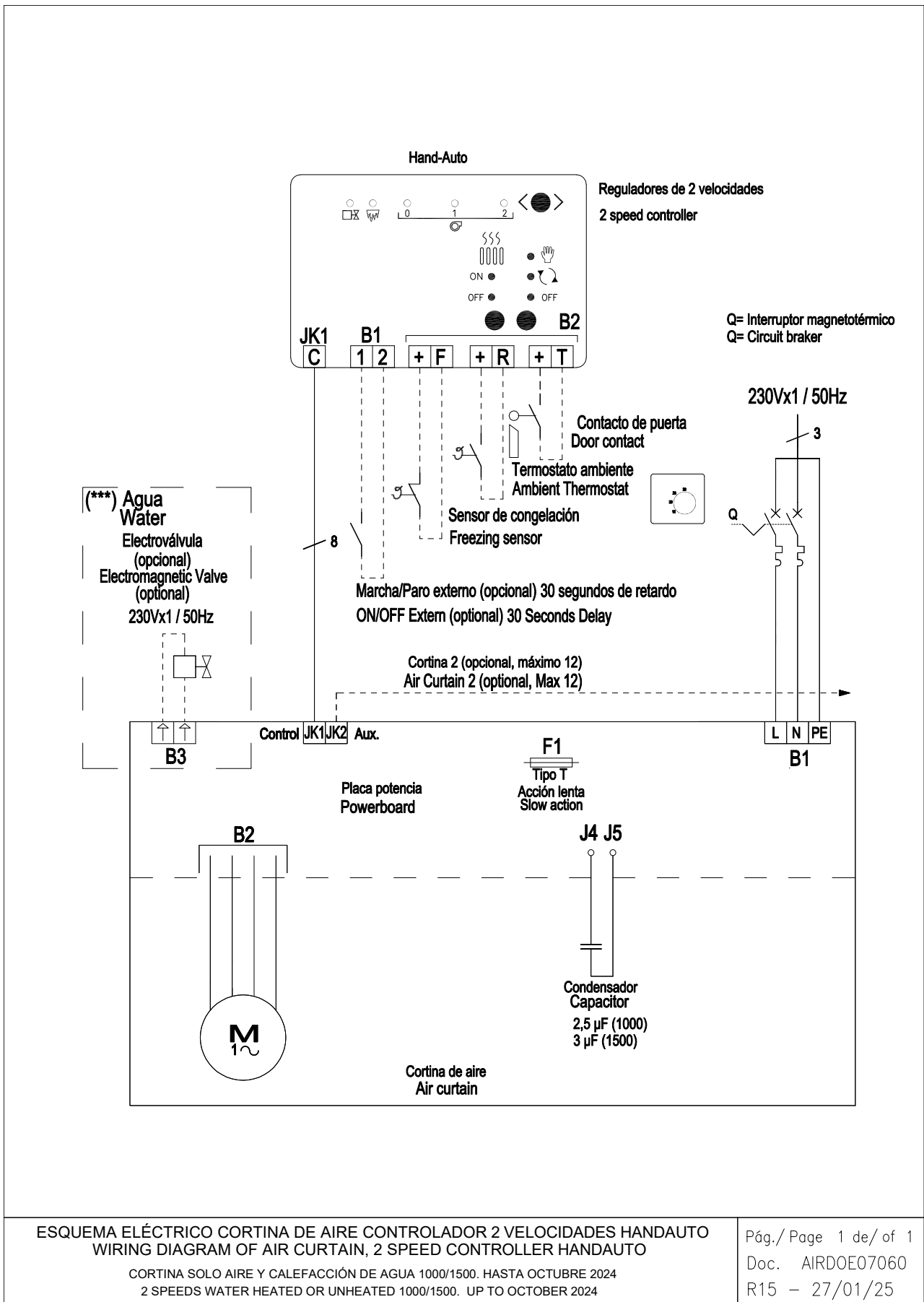

In case there is a need to connect the curtain to a PLC, the corresponding diagram is attached.

**Electric curtain 400V~3 with PRBEO and electric control models 1000 6kW and 1500 6 and 9kW.
Diagram AIRDOE07100**

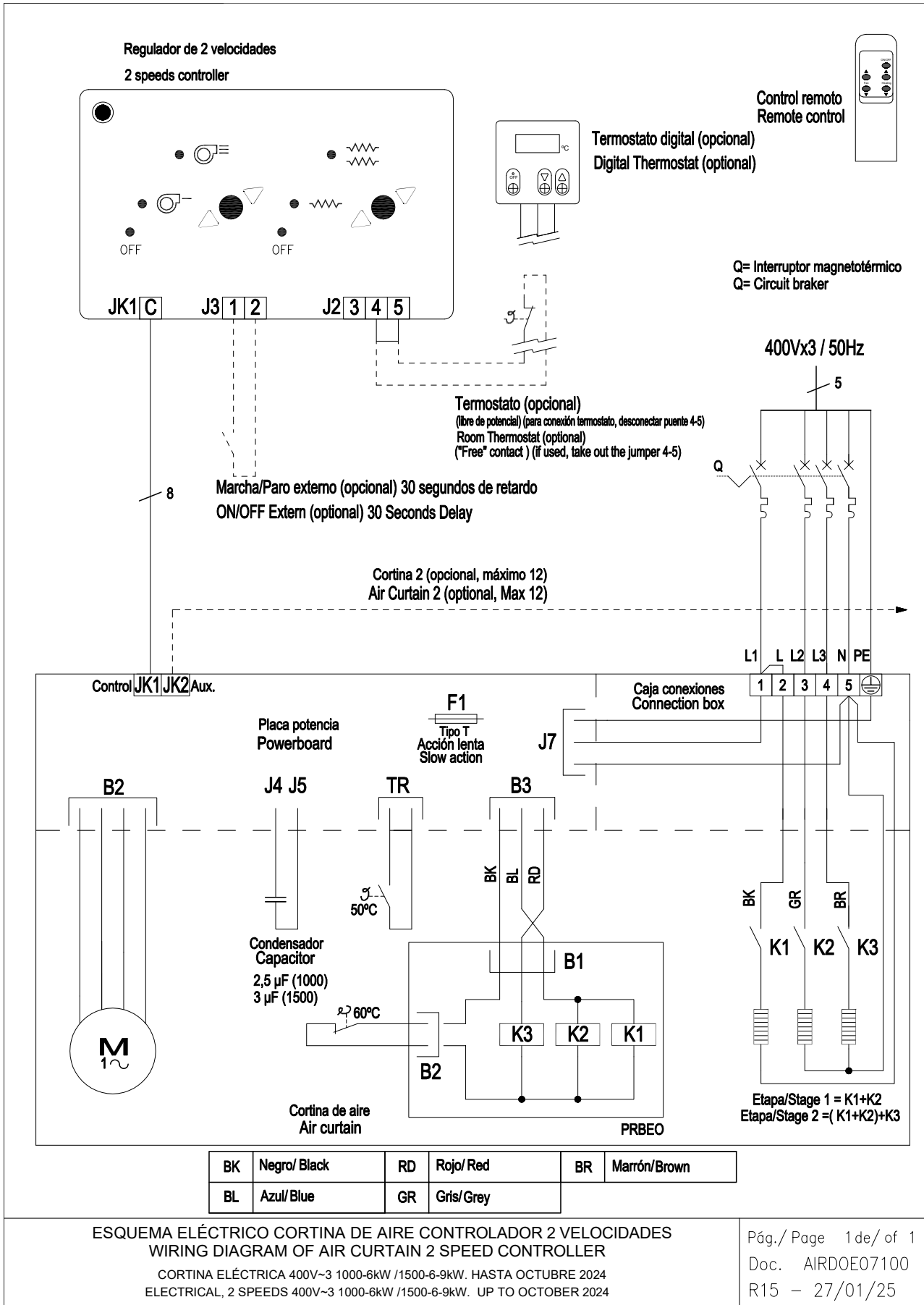

In case there is a need to connect the curtain to a PLC, the corresponding diagram is attached.

Electric curtain 400V~3 with PRBEO and electric control 1000-9kW. Diagram AIRDOE07200

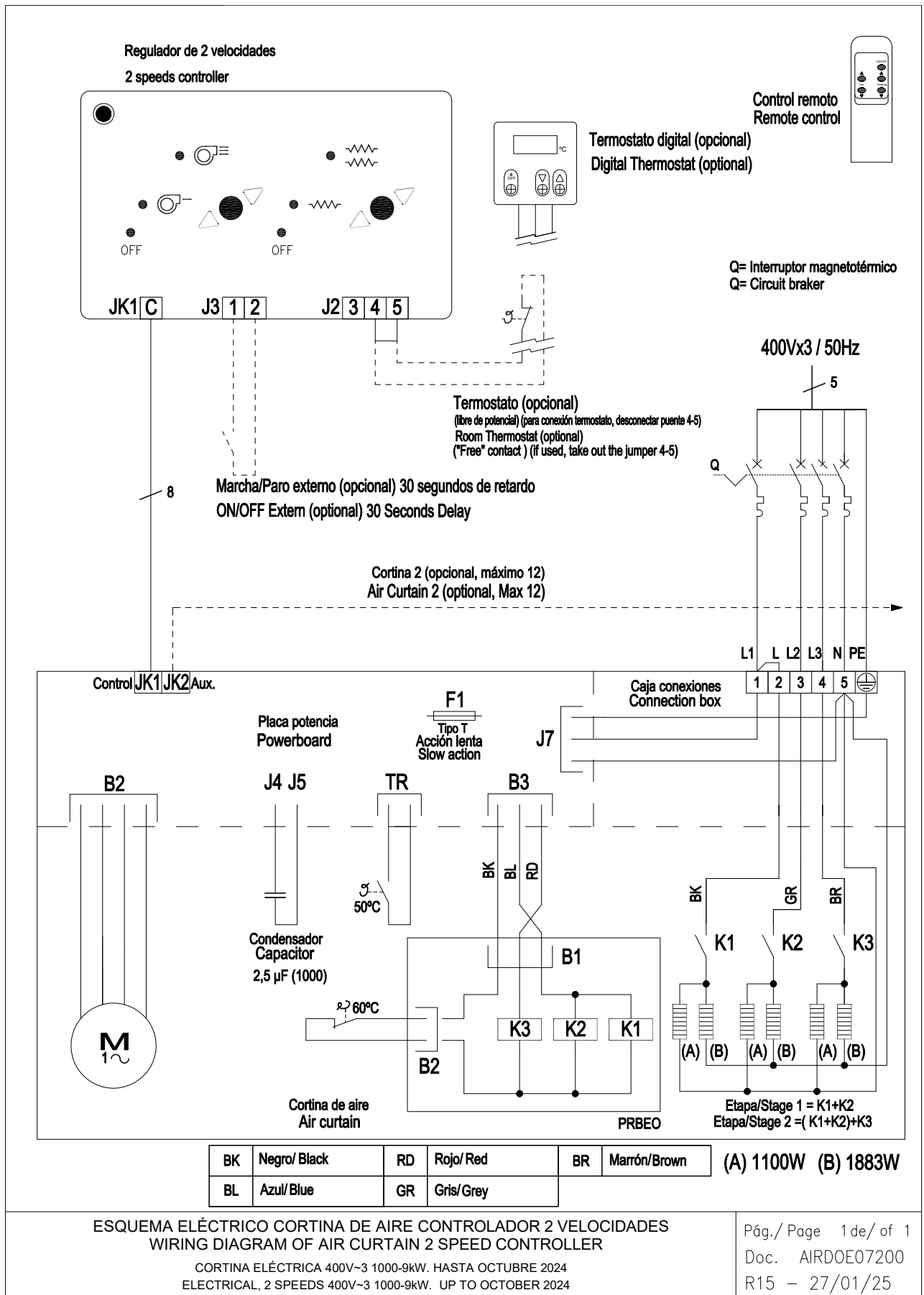

In case there is a need to connect the curtain to a PLC, the corresponding diagram is attached.

**Electric curtain 230V~1 models 1000 and 1500 6 kW and electric control.
Diagram AIRDOE07190**

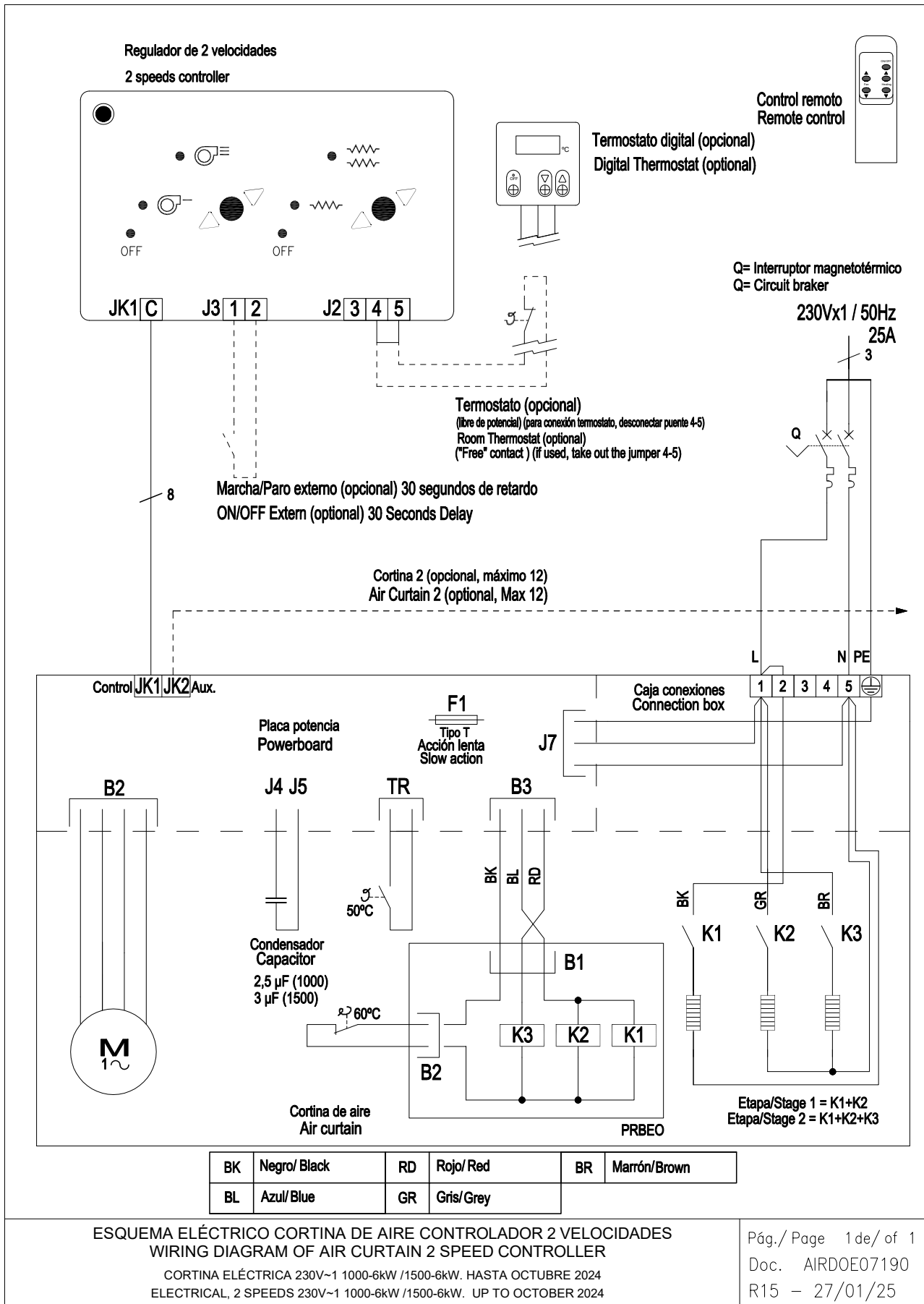

In case there is a need to connect the curtain to a PLC, the corresponding diagram is attached.

Electric curtain 230V~1 and electric control 1000 E230-9kW. Diagram AIRDOE07215

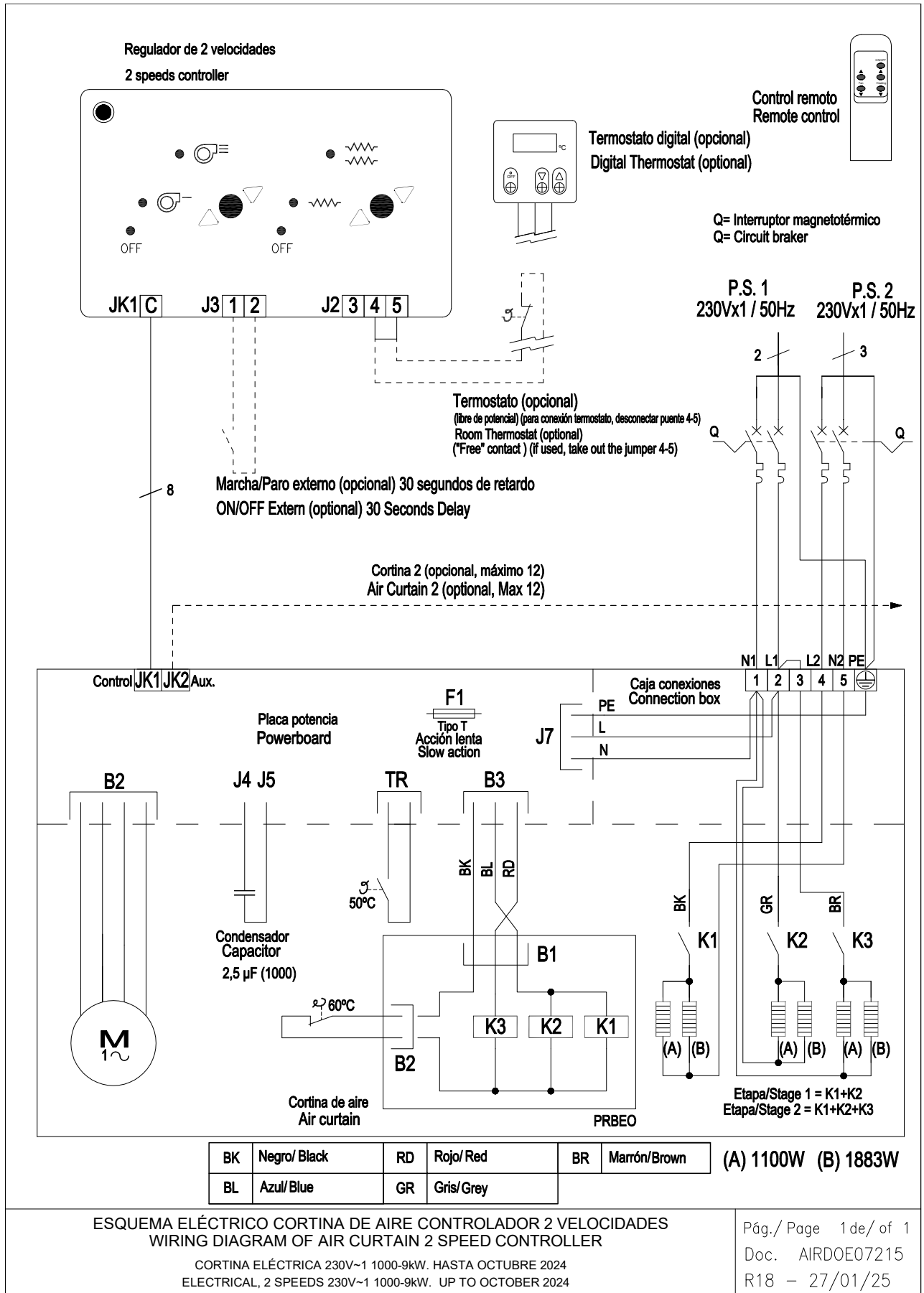

In case there is a need to connect the curtain to a PLC, the corresponding diagram is attached.

Electric curtain 230V~1 and electric control 1500 E230-9kW. Diagram AIRDOE07195

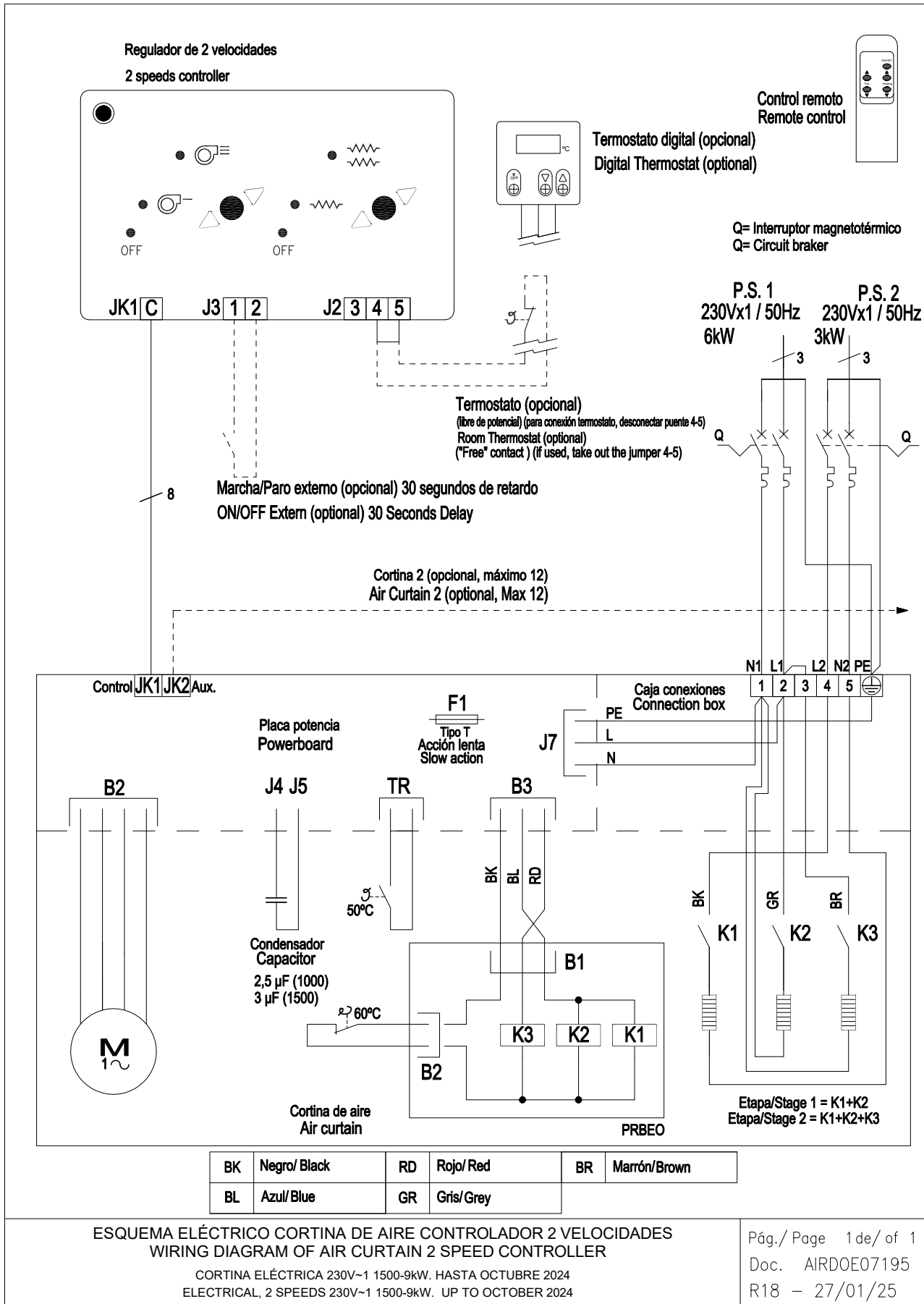

In case there is a need to connect the curtain to a PLC, the corresponding diagram is attached.

**Curtain with water battery or without battery with standard control model 2000.
Diagram AIRDOE07150**

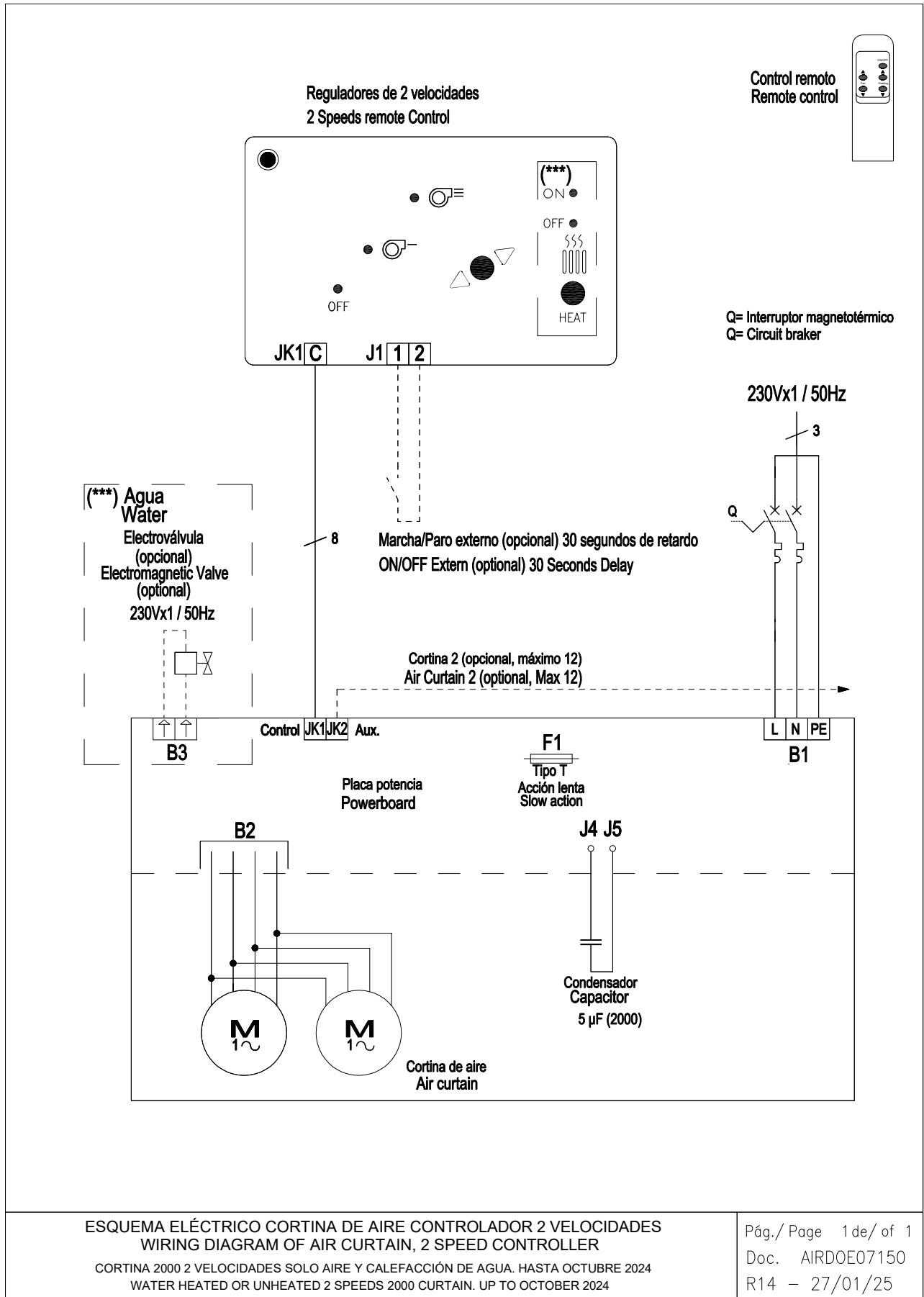

In case there is a need to connect the curtain to a PLC, the corresponding diagram is attached.

**Curtain without battery or with water battery model 2000 with Hand Auto.
Diagram AIRDOE07065**

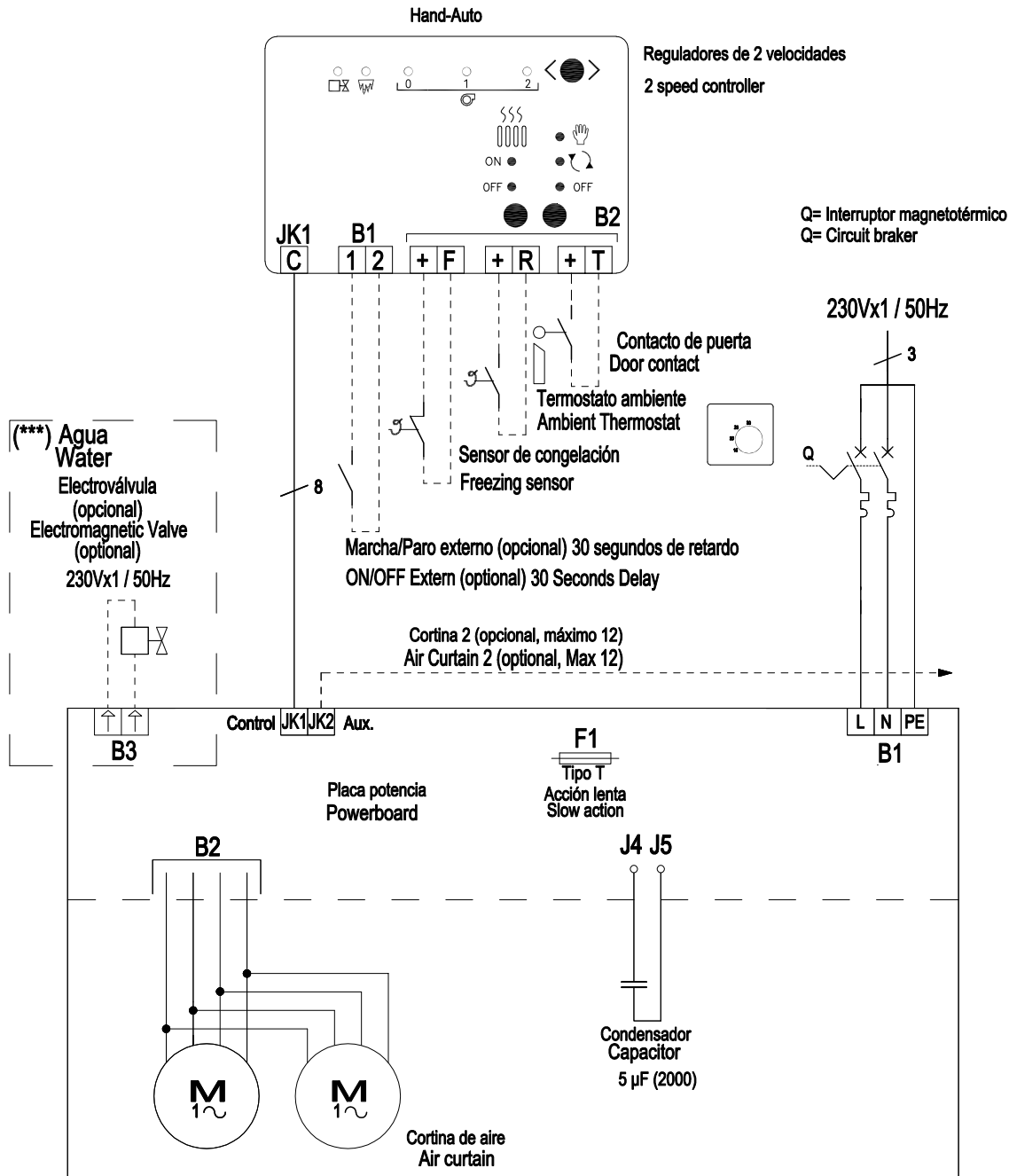

ESQUEMA ELÉCTRICO CORTINA DE AIRE CONTROLADOR 2 VELOCIDADES HANDAUTO
WIRING DIAGRAM OF AIR CURTAIN, 2 SPEED CONTROLLER HANDAUTO

CORTINA SOLO AIRE Y CALEFACCIÓN DE AGUA 2000. HASTA OCTUBRE 2024
2 SPEEDS WATER HEATED OR UNHEATED 2000. UP TO OCTOBER 2024

Pág./ Page 1 de/ of 1
Doc. AIRDOE07065
R15 - 27/01/25

In case there is a need to connect the curtain to a PLC, the corresponding diagram is attached.

Electric curtain 400V~3 model 2000 and electric control. Diagram AIRDOE07160

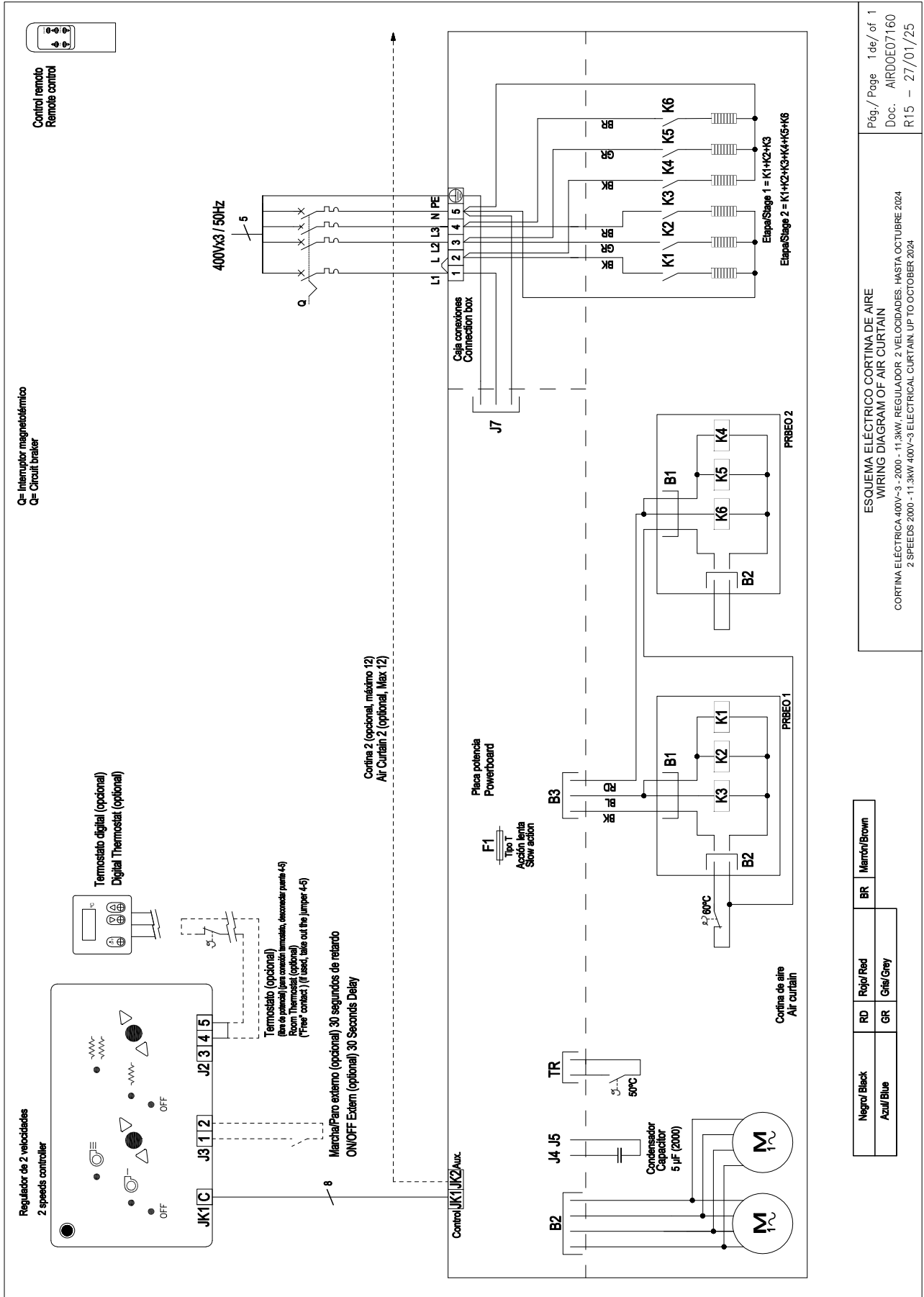

In case there is a need to connect the curtain to a PLC, the corresponding diagram is attached.

Electric curtain 230V~1 with PRBEO model 2000 and electric control. Diagram AIRDOE07170

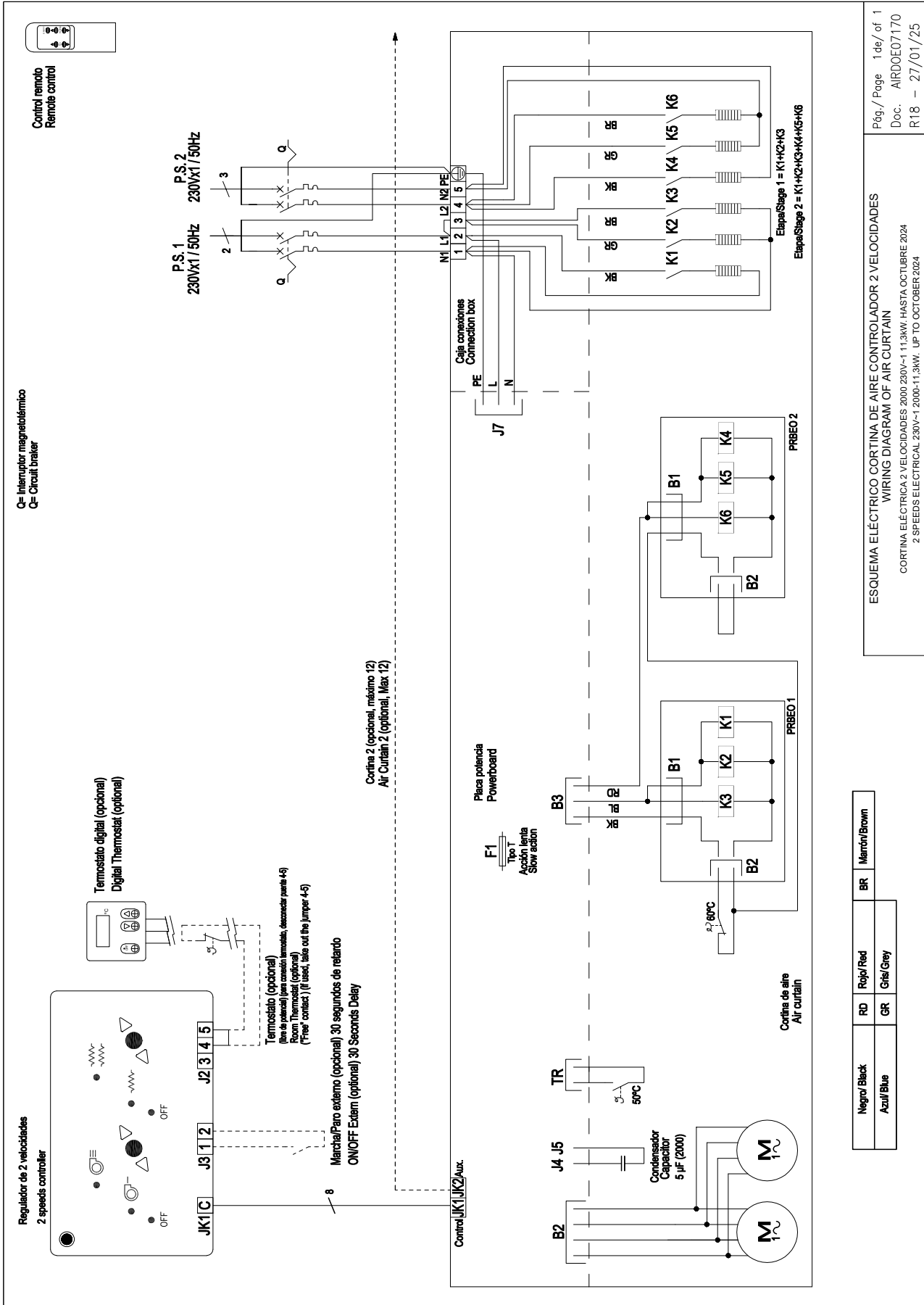

Negro/Black	RD	Rojol/Red	BR	Marrón/Brown
Azul/Blue	GR	Gris/Grey		

ESQUEMA ELÉCTRICO CORTINA DE AIRE CONTROLADOR 2 VELOCIDADES
WIRING DIAGRAM OF AIR CURTAIN
CORTINA ELÉCTRICA 2 VELOCIDADES 2000 230V~1 11,3kW. HASTA OCTUBRE 2024
2 SPEEDS ELECTRICAL 230V~1 2000-11,3kW. UP TO OCTOBER 2024

In case there is a need to connect the curtain to a PLC, the corresponding diagram is attached.

ARIS

STANDARD AIR CURTAINS
FOR COMMERCIAL DOORS

Technical Features



RAL 9016
standard



Other colors
on request



Range
Up to 3,5 m



Airflow / Length
1600 - 3600 m³/h
1 m to 2 m



Fan
Tangential
2-speed



Heating type
A : unheated
E : electrical 3 stages
P : water



Heating capacity
E : 3 - 18 kW
P : 7,27 - 19,34 kW



Control
Plug&Play manual regulator
+ IR remote control
(Optional Clever Control)



Casing
Galvanised steel



Inlet grille
Rectangular perforated



Outlet lamellas
Aluminium, airfoil type

ARIS contemporary, discreet and elegant air curtain that features a smooth front panel with rounded edges and shapes, customizable with logos, lighting, signage or safety and informational signs. The inlet grille is hidden in the upper part, thus avoiding the internal vision of the air curtain. It incorporates tangential fans with low noise twisted profile turbine and 2-speed external rotor motor.

UNHEATED

Model	Airflow m ³ /h	Ventilation power 230V~50Hz W	Ventilation current 230V~50Hz A	Noise level (5 m) dB(A)	Weight kg
ARIS 1000 A	1900	123	0,59	37/52	20,5
ARIS 1500 A	2000	207	0,96	38/53	32
ARIS 2000 A	3000	253	1,10	39/54	39

ELECTRIC HEATED

Model	Airflow m ³ /h	Electrical heating capacity (*) kW	Power supply	Ventilation power 230V~50Hz W	Ventilation current 230V~50Hz A	Noise level (5 m) dB(A)	Weight kg
ARIS 1000 E	1800	3/6/9	400Vx3	131	0,59	37/52	24,5
ARIS 1500 E	2800	4/8/12	400Vx3	207	0,96	38/53	35
ARIS 2000 E	3600	6/12/18	400Vx3	253	1,10	39/54	50

(*) Under request other electrical heating power can be limited.

WATER HEATED

Model	Airflow m ³ /h	P06 (00/60°C)		P04 (60/40°C)		Ventilation power 230V~50Hz W	Ventilation current 230V~50Hz A	Noise level (5 m) dB(A)	Weight kg
		Water heating capacity kW	Water pressure drop Pa	Water heating capacity kW	Water pressure drop Pa				
ARIS 1000 P06	1750	9,32	0900	-	-	116	0,53	39/53	23,5
ARIS 1000 P04	1600	-	-	7,27	0520	107	0,48	39/53	23,5
ARIS 1500 P06	2625	14,5	9150	-	-	187	0,86	40/54	34
ARIS 1500 P04	2350	-	-	11,15	0490	172	0,83	40/54	34
ARIS 2000 P06	3500	19,34	0490	-	-	222	1,03	41/55	43,5
ARIS 2000 P04	3200	-	-	15,00	0140	206	0,90	41/55	43,5

Water heated: connection pipes 1/2" female. P06 of 2 rows coil. P04 of 3 rows coil.

No model exceeds the 70dB of noise level.

Dimensions

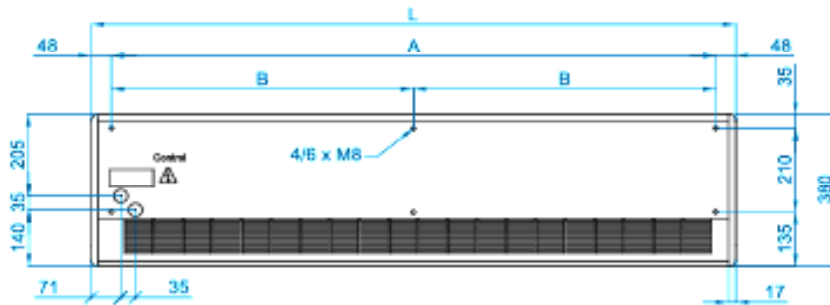

Smooth or customizable front panel with logos, lighting or signage

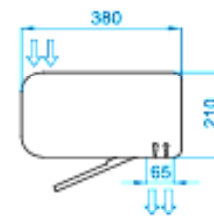
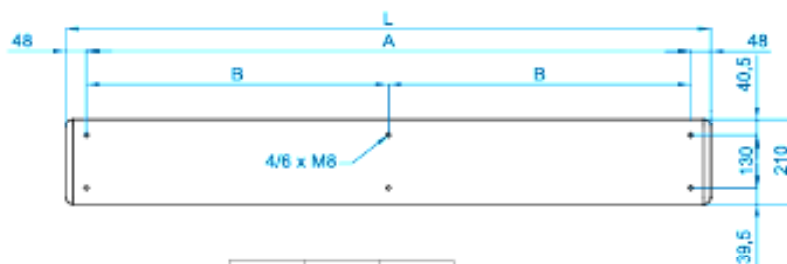

	L	A	B
ARIS 1000	1034	940	-
ARIS 1500	1534	1440	-
ARIS 2000	2034	1940	970



Selection program

CAD drawings, BIM files, installation manuals and other documentation



Optional accessories

Supports and installation



Wall rail support
SPWR



Silentblock supports
SPANG-SIL / SLB



Suspension cables
SPCT

Control



Basic control
✓ Included



IR Control
✓ Included



RJ45 Cable
✓ Included



Clever control kit

Sensors and valves



Magnetic door contact
DC-MAG



Mechanical door contact
DC-MEC



External Temperature
Sensor



Solenoid valve
V-S (ON/OFF)



Proportional valve
V-ACT







Valve 3 ways
V-T



Anti-freezing sensor
AFS-INS

MAINTENANCE INSTRUCTIONS

	For safety, before cleaning, stop the curtain through the controller and disconnect the device from the current.
 	Do not open the service door (risk of electric shock and entrapment in the fans). Repairs must be carried out exclusively by authorized personnel.
	The inside of the device must not be cleaned with water or steam.

Indicative periodicity of maintenance

N° Action	Action	Frequency
1	Cleaning of the suction grill	Bi-monthly (recommended monthly)
2	Exterior cleaning	Semiannual (recommended quarterly)
3	Interior cleaning	Semiannual (recommended quarterly)
4	Internal inspection	Biannual (recommended annual)
5	Consumption and auditory control	Biannual (recommended annual)
6	Water heating maintenance	Semiannual (recommended quarterly)
7	Electrical heating maintenance	Semiannual (recommended quarterly)

Suction grille cleaning

The suction grille prevents the entry of objects into the internal elements. It is highly recommended to check that the suction grille is free of any object that could prevent air from entering (plastic bags, paper, etc.). It is recommended to clean the suction grille monthly. In addition, it is important to make sure that the air curtain is off, otherwise the mixture between the dust and a damp cloth would form a paste of dirt that could damage the fan rotor when it sucks in the air or clog the water battery.

An annual cleaning of the discharge area must be carried out.

It is advisable to do it frequently (depending on the dirt generated) since performance is considerably reduced.



Exterior cleaning

Wipe the entire outer surface of the air curtain (except the suction grille) with a damp cloth to trap dust particles. In addition to the damp cloth, neutral soaps that do not contain acids or are caustic can be used.



Interior cleaning

It is recommended to clean the inside of the unit with a vacuum cleaner at least once every 2 years. (*) It is recommended to clean the inside of the equipment frequently with the help of a vacuum cleaner, especially before the arrival of winter. (*)

(*) These periods are indicative depending on the conditions of each installation. In places with a high number of suspended particles, it is desirable to increase the frequency of interior cleaning.



Internal components visual inspection

Check that the regulation board have not suffered any damage and that they are securely fastened to the equipment frame. Make sure that the board and internal wiring connectors are still well connected. Check that the motors do not move from their mountings and check that the turbines have no impediments to rotate freely (turn it by hand, first turn off the device).

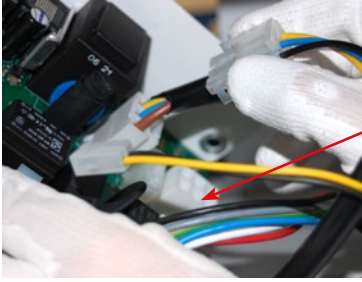

Air curtain consumption and auditory control checking

Write down the consumption value of the fans that appears on the product label (located on the inside of the service door). Close the door, give power supply to the air curtain and with the help of an ammeter, check that the electrical consumption of the air curtain at maximum speed is between 110% and 85% of the value indicated on the label. Check that all fans blow air. Keep the air curtain at full speed for a few minutes and listen for abnormal noises from the air curtain.



Heating maintenance

To ensure good heat transmission in the air curtain exchanger, it is recommended to check the battery as follows:

Battery cleaning

With both electric battery and water battery, must be cleaned periodically with pressurized air.



Water Heating

Check the inlets and outlets of the water tubes to ensure that there are no fluid leaks.



If a water leak has been detected in the battery, possible corrosion problems in both the battery and the air curtain components should be checked.

Electrical heat

Check that no cable has been disconnected from the battery circuit:



Resistance type for Aris models in all their lengths

To verify the correct operation of the component, check the battery consumption per heating stage. Theoretical consumptions are shown below:



Air Curtain Models	Heating Stage	Power by stage (kW)	Theoretical consumption (A) 400Vx3		
			L1	L2	L3
1000 9kW	1	3	13	0	0
	2	6	13	13	0
	3	9	13	13	13
1500 12kW	1	4	8,7	0	8,7
	2	8	8,7	17,4	8,7
	3	12	17,4	17,4	17,4
2000 18KW	1	6	13	0	13
	2	12	13	26,1	13
	3	18	26,1	26,1	26,1



REPAIRS AND REPLACEMENTS

Assembly and electrical connection must be carried out exclusively by specialized professionals and in compliance with these instructions.

Before carrying out any repair, it is necessary to:

	<ul style="list-style-type: none"> • Notify staff and indicate that work is being done. • Disconnect the current and protect the circuit breaker.
	<ul style="list-style-type: none"> • Be sure there is no voltage in the unit.
	<ul style="list-style-type: none"> • Be sure the fans have stopped. • Use only original spare parts.



CODE	COMPONENT	COMPONENT REFERENCE	CURTAIN MODEL
AIRCON12052	PCB Optima 2 speed air	AC 2S-E	Aris 1000, 1500 and 2000 air
AIRCON12052	PCB Optima 2 speed electrical	AC 2S-E	Aris 1000, 1500 and 2000 electrical
AIRCON12051	PCB Optima 2 speed water	AC 2S-W	Optima 1000, 1500 and 2000 water
ECOCME06045	External rotor motor	4REC35 62Z X22-05	Aris 1500
ECOCME06085	External rotor motor	4RET45-55S Y18-03	Aris 1000 and 2000
ECOCME06046	External rotor motor	4REC35 J10-A0	Aris 1500
ECOCME06046	External rotor motor	4REC35 J10-A0	Aris 2000
VERCCO33015	Optima air 2 speed regulator IR receptor	CA-2AO-IR	Aris : Air
VERCCO33017	Optima water 2 speed regulator IR receptor	CW-2EV-IR	Aris: Water (P86)
VERCCO33020	Optima electrical 2 speed regulator IR receptor	CE-2AO-IR	Optima: Electrical

Service door opening

Aris model

1. Gently pull between the grille and the door with a flathead screwdriver and open the service door with both hands.

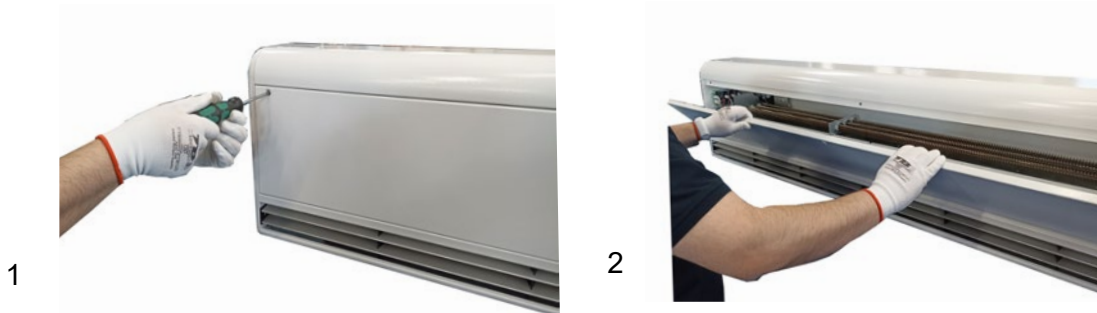

Motor replacement

Before changing the power board or fuse, notify and indicate that work is being done, disconnect the power supply, make sure that there is no voltage and that the machine has stopped.

Next, remove the lateral panels as shown before, open the grille, identify and release the motor cables. Remove the lateral (4 screws), unscrew the motor, unscrew the turbine from the shaft and mount the replacement motor following the process in reverse order.

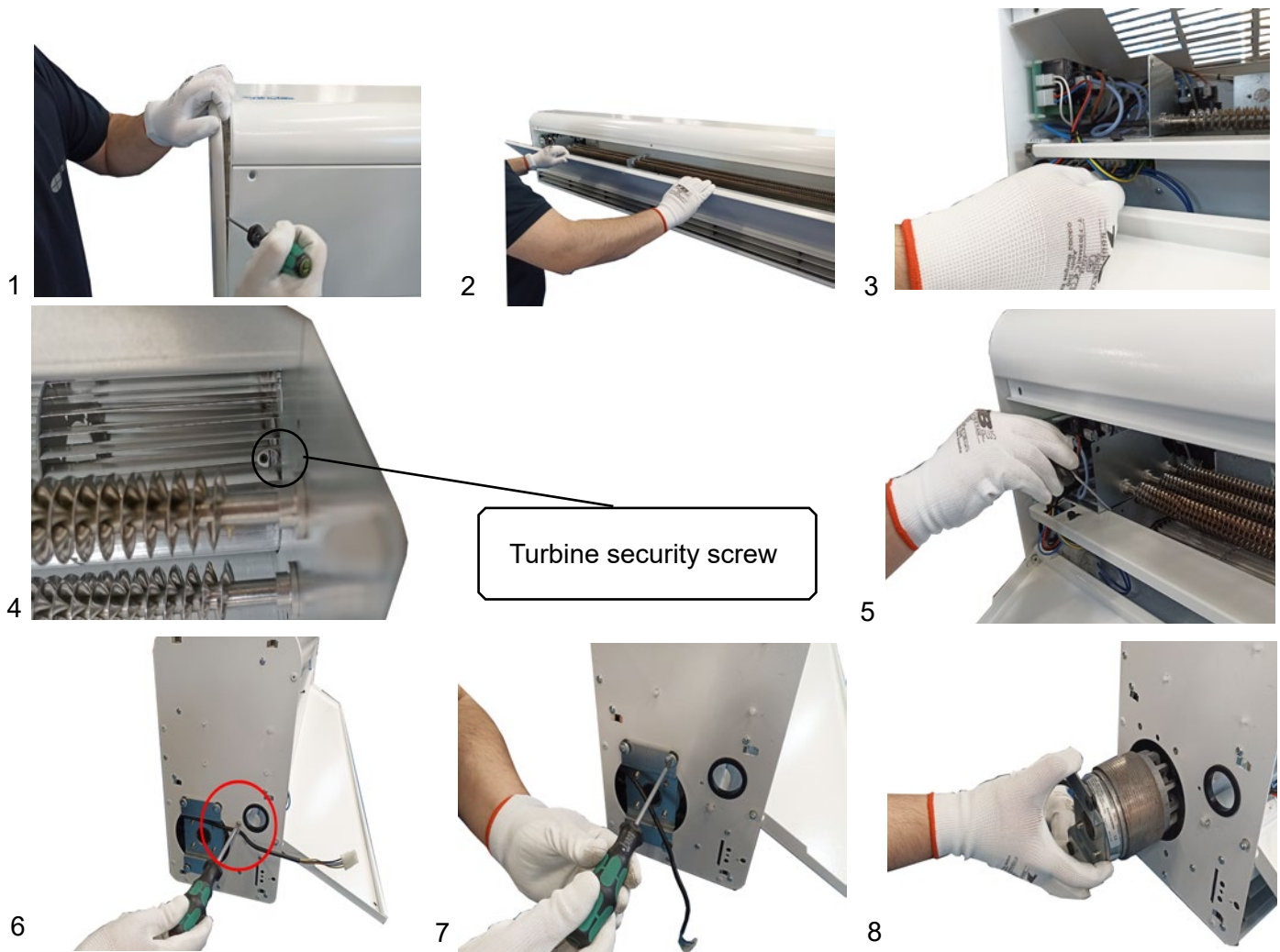

Fuse or board replacement

Before changing the power board or fuse, notify and indicate that work is being done, disconnect the power supply, make sure that there is no voltage and that the fans have stopped.

Change power board: open the service door and disconnect the cables from the PCB. Remove the power plate fastening screws from the inside of the curtain to remove the plate and carry out the necessary repair.

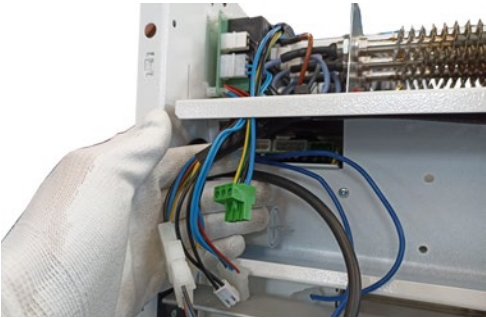

Change fuse: remove the pcb from the curtain for better maneuverability, remove the fuse protection casing and remove the fuse by hand or with the help of a screwdriver. Proceed to make the replacement and follow the reverse process to leave the curtain functional.

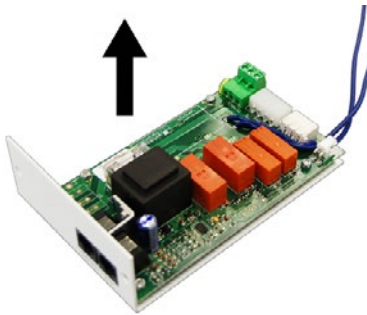

Recommendation: installation with silentblocks

To reduce the sound level and the vibrations of the air curtain, it is recommended to carry out an installation with silentblocks:



Water heating replacement

Warning! The curtain is not designed to operate in cold mode. Do not circulate cold water through the battery.

Before changing the battery, warn and indicate that work is in progress, disconnect the power supply, make sure that there is no voltage and that the fans have stopped.

1. Close the building's water inlet and outlet valves up to the air curtain.
2. Remove the screws from the service door and open it with both hands.



3. Remove the suction grille, unscrew the screws that hold water coils battery to the air curtain housing.

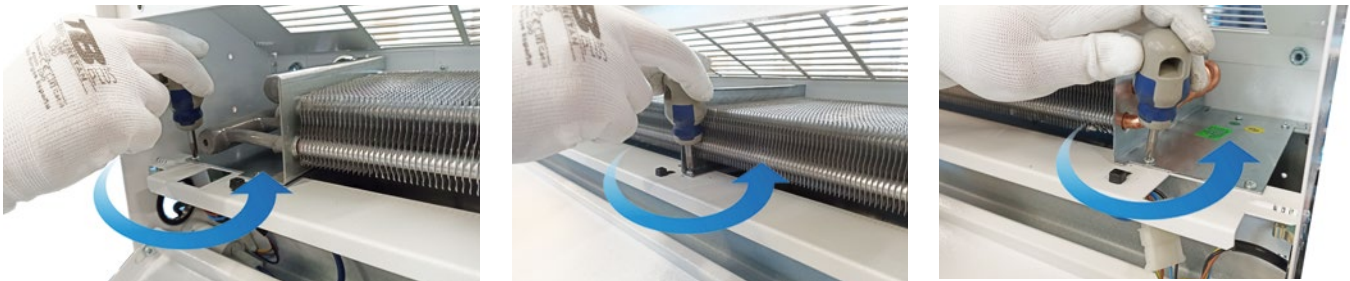

4. Drain the water battery with the drain plug of the main collector as shown in the picture and disconnect the battery from the installation.
5. Remove the battery from the air curtain housing.

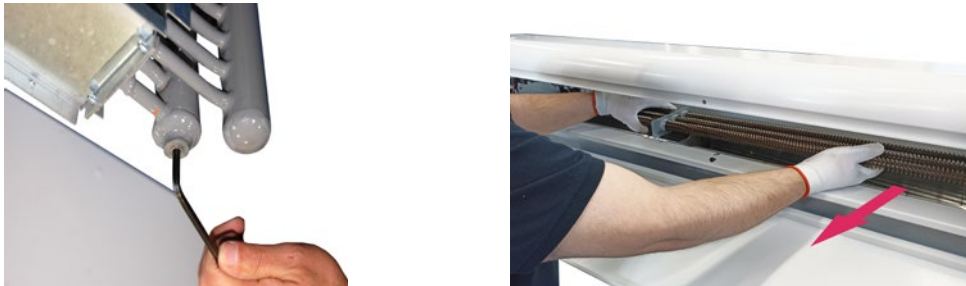

Electrical heating replacement

Disconnect the power supply from the battery. To do this, remove the black connection box from the air curtain housing.



To remove the battery, remove the suction grille (process shown in water battery). Unscrew the fixing screws (see table at the bottom of the page to count the screws to be removed), disconnect the PRBEO cables from both parts of the battery and remove the battery with both hands.

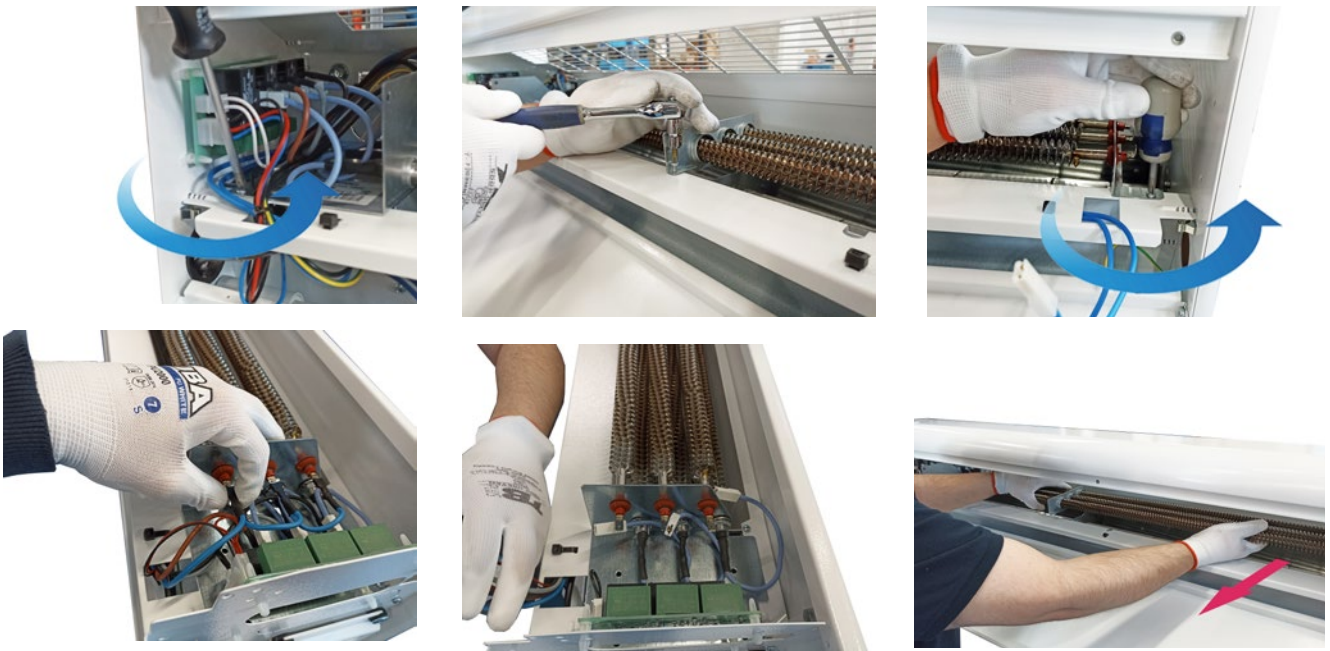

Air curtain size	N° battery fixing screws
1000	4
1500	6
2000	6

FAULTS AND SOLUTIONS

More than **95% of the claims** occur during the start-up of the equipment and are due to installation errors. Reviewing the following 3 points solves more than 90% of the incidents:

A) RJ45 cable manipulated: the cable connecting the control to the air curtain is an 8-way crossover RJ45 cable. If it is manipulated (cut or remove the connector) and spliced backwards, the shade will not work properly and may also damage the electronics. Only re-splicing the connector correctly solves the problem (connection diagram).

B) RJ45 cable wrong connection. Check if the position of the connector is correct between “control” or “auxiliary” according to the installation diagram (especially if there is more than one air curtain with a single controller).

C) Incorrect power supply. The supply of the air curtain depends on the type of current available and the type of heating of the equipment. Connect following the diagram scheme.

Most commons problems and solutions		
Symptom	Problem	Solution
No light on remote control	Is the RJ45 cable the original without splices or shortening?	Change the cable or reconnect it correctly.
	Does the current reach the connection box?	Correctly connect the terminals of the connection box: Between L and N there must be 230V. If the curtain has a three-phase electric battery, there must be 400V between terminals L1, L2 and L3.
	Is the control connected to the “Control” connector on the board?	Connect the control cable to the “Control” connector on the board (printed circuit), never to the “Aux”.
	Is the fuse on the board in good condition?	Check the fuse and change it if necessary (type T, slow action).
Some lights on the remote control flash	The green maximum speed LED flashes when the curtain stops after having been running with heating	It is not a bug, but a security mechanism. The curtain runs at full speed to cool down and protect components. When it drops below the safety temperature it will stop
	Speed or heating lights flash with the air curtain running	<p>It is a protection mechanism for the curtain so that the internal components are not damaged.</p> <p>Situations in which the problem is continually repeated and how to avoid them:</p> <ol style="list-style-type: none"> 1. Clogged suction grille (dirt, objects...) the temperature of the air inside the equipment can increase a lot if it does not circulate correctly. Keep the fence clean. 2. Small room size: it is recommended to install a thermostat to regulate the heating power without the protection being activated. 3. If the ambient temperature of the room is high, it is recommended to lower the heating power or install a thermostat 4. Suction of already hot air coming from a heating equipment outside the air curtain. Move the curtain away, put a thermostat on the suction or lower the heating power. 5. Some motor does not work: notify the technical service.
The heating does not work	Does the triphasic current reach the connection box?	Check installation.
The speed and/or the heating vary constantly for no apparent reason but the control lights do not flash	Surely the telephone type cable passes near sources of interference, emitters, cable trays, especially those that feed motors, etc.	Run the cable as far away as possible from sources of interference (especially on long runs) or use a shielded cable

DECLARATION OF CONFORMITY



Declaration **CE** of conformity / Declaración **CE** de conformidad

Manufacturer **Motors i Ventiladors S.L. (AIRTÈCNICS)**
Fabricante **Conca de Barberà 6, Pol. Ind. Pla de la Bruguera**
08211 Castellar del Vallès (Barcelona) Spain

We declare, under our sole responsibility, that the product
Declaramos, bajo nuestra única responsabilidad, que el producto

Air Curtains
Cortinas de aire

with models / *con los modelos*

Minibel, Optima, Recessed Optima, Optima Wireless, Recessed Optima Wireless, Optima K, Optima Switch, Top, Recessed Compact, Aris, Windbox, Recessed Windbox, Smart, Dam, Recessed Dam, Deco, Kool, Rund, Invisair, Rotowind, Variwind, Zen, Max, Maxwell, Compact Fly, Fly K, Fly KL-KXL, Fly KBB, Windbox BB, Recessed Windbox BB, Zen BB, Windbox L-XL, Duojet, Triojet System

is/are developed, designed and manufactured in accordance with the following directive(s)
ha(n) sido desarrollado(s), diseñado(s) y fabricado(s) de acuerdo con la(s) siguiente(s) directiva(s)

Low Voltage Directive 2014/35/EU
Directiva Baja Tensión 2014/35/UE

Electromagnetic Compatibility Directive 2014/30/EU
Directiva Compatibilidad Electromagnética 2014/30/UE

Restriction Certain Hazardous Substances Directive 2011/65/EU (RoHS)
Directiva Restricción Substancias Peligrosas 2011/65/UE

Eco-design Energy-related Products Directive 2009/125/EC
Directiva Diseño Ecológico Productos Con Energía 2009/125/CE

applying the following harmonized standards in particular
aplicando las siguientes normas armonizadas en particular

LVD: EN 60335-1:2012 + AC:2014 + A11:2014 + A13:2017 + A1:2019 + A:14:2019 + A2:2019
EN 60335-2-30:2009 + A11:2012 + A1:2020 + A12:2020

EMC: EN 61000-3-11:2000
EN 61000-3-12:2011
EN 55014-1:2017 + A11:2020
EN 55014-2:2015
EN 62233:2008 + AC:2008

RoHS: EN 50581:2012

Date / Fecha
Name / Nombre
Position / Cargo

25/09/2023
Jordi Hierro
Technical Manager / Director Técnico

MOTORS I VENTILADORS, S.L.
ESB58967183 - C/ Conca de Barberà, 6
08211 Castellar del Vallès
Tel. 937159988 - Fax 937159989

UK
CA

UK Declaration of conformity

Manufacturer **Motors i Ventiladors S.L. (AIRTÈCNICS)**
Conca de Barberà 6, Pol. Ind. Pla de la Bruguera
08211 Castellar del Vallès (Barcelona) Spain

We declare, under our sole responsibility, that the product

Air Curtains

with models

Minibel, Optima, Optima Swich, Recessed Optima, Optima Wireless, Recessed Optima Wireless, Optima K, Top, Recessed Compact, Aris, Windbox, Recessed Windbox, Smart, Dam, Recessed Dam, Deco, Kool, Rund, Invisair, Rotowind, Variwind, Zen, Max, Maxwell, Compact Fly, Fly K, Fly KL-KXL, Fly KBB, Windbox BB, Recessed Windbox BB, Zen BB, Windbox L-XL, Duojet, Triojet System.

is/are developed, designed and manufactured in accordance with the following regulation(s)

Electrical Equipment (Safety) Regulations 2016 No. 1101

Electromagnetic Compatibility Regulations 2016 No. 1091

The Restriction of the Use of Certain Hazardous Substances in Electrical and Electronic Equipment Regulations 2012 No. 3032

The Ecodesign for Energy-Related Products and Energy Information (Amendment) (EU Exit) Regulations 2019 No. 539

applying the following harmonized standards in particular

LVD: BS EN 60335-1:2012+A2:2019
BS EN 60335-2-30:2009+A12:2020

EMC: BS EN IEC 61000-3-11:2019
BS EN 61000-3-12:2011
BS EN IEC 55014-1:2021
BS EN IEC 55014-2:2021

RoHS: BS EN IEC 63000:2018

Date
Name
Position

16/10/2023
Jordi Hierro
Technical Manager



MOTORS I VENTILADORS, S.L.
ESB58967183 - C/ Conca de Barberà, 6
08211 Castellar del Vallès
Tel. 937159988 - Fax 937159989

Conca de Barberà, 6 - Pol. Ind. Pla de la Bruguera
E-08211 Castellar del Vallès (Barcelona) Spain
☎ + 34 93 715 99 88
airtecnicos@airtecnicos.com

www.airtecnicos.com



AIRDOM05230-R16(01/25)

Airtècnics reserves the right to modify some of the specifications in this manual.