



**Characteristics**



- Stylish, discreet and contemporary design adaptive to any interior architecture.
- Smooth front panel can be customized with logotypes, lighting, lettering or safety and informative signals, according to the client requirements.
- Self-supporting steel rounded casing with edgeless plastic side covers, finished in structural epoxy-polyester painting white colour RAL9016 as standard. Other colours are available on request.
- Hidden top air entrance, avoiding the inside view of the unit and the inlet grille.
- Anodized aluminium outlet vanes, airfoil shaped, adjustable from 0 to 15° each side.
- Double-inlet centrifugal fans driven by an external rotor motor and low noise level. 5-speed selector. "EC" models with very low consumption efficient fans.
- "P" type with water heated coil. "E" type with electrical shielded elements, three stages with integrated regulation. "A" type without heating, air only. Optional "DX" with direct expansion coil.
- Includes Plug&Play control with 7m RJ45 cable and infrared remote control. Optional: Clever control (programmable, automatic, intelligent, energy saving, Modbus RTU for BMS...).

**Specifications**

**AIR ONLY**

Model	Airflow m³/h	Power Fans		Current Fans A	Noise Level (5m) dB(A)	Weight kg
		230V-50Hz kW	230V-50Hz A			
SMART M 1000 A	1800	0,212	0,94	53	34	
SMART M 1500 A	2700	0,318	1,41	54	50	
SMART M 2000 A	3600	0,424	1,88	55	62	
SMART M 2500 A	4500	0,530	2,35	56	66	
SMART M 3000 A	5400	0,636	2,82	57	76	
SMART ECM 1000 A	1840	0,142	1,24	54	34	
SMART ECM 1500 A	2760	0,213	1,86	55	50	
SMART ECM 2000 A	3680	0,284	2,48	56	62	
SMART ECM 2500 A	4600	0,355	3,10	57	66	
SMART ECM 3000 A	5520	0,426	3,72	58	76	
SMART G 1000 A	2400	0,642	2,85	55	38	
SMART G 1500 A	3200	0,856	3,80	56	55	
SMART G 2000 A	4800	1,284	5,70	57	72	
SMART G 2500 A	5600	1,498	6,65	58	76	
SMART G 3000 A	6400	1,712	7,60	59	86	
SMART ECG 1000 A	2700	0,213	1,86	59	38	
SMART ECG 1500 A	3600	0,284	2,48	60	55	
SMART ECG 2000 A	5400	0,426	3,72	61	72	
SMART ECG 2500 A	6300	0,497	4,34	62	76	
SMART ECG 3000 A	7200	0,568	5,96	63	86	

**ELECTRICAL HEATED**

Model	Airflow m³/h	Electrical Heating		Power Fans 230V-50Hz kW	Current Fans A	Noise Level (5m) dB(A)	Weight kg
		Capacity 400Vx3-50Hz kW	Capacity 230V-50Hz kW				
SMART M 1000 E	1800	3/6/9	0,212	0,94	53	41	
SMART M 1500 E	2700	4/8/12	0,318	1,41	54	62	
SMART M 2000 E	3600	6/12/18	0,424	1,88	55	80	
SMART M 2500 E	4500	6/12/18	0,530	2,35	56	86	
SMART M 3000 E	5400	8/16/24	0,636	2,82	57	99	
SMART ECM 1000 E	1840	3/6/9	0,142	1,24	54	41	
SMART ECM 1500 E	2760	4/8/12	0,213	1,86	55	62	
SMART ECM 2000 E	3680	6/12/18	0,284	2,48	56	80	
SMART ECM 2500 E	4600	6/12/18	0,355	3,10	57	86	
SMART ECM 3000 E	5520	8/16/24	0,426	3,72	58	99	
SMART G 1000 E	2400	5/10/15	0,642	2,85	55	46	
SMART G 1500 E	3200	7,5/15/22,5	0,856	3,80	56	68	
SMART G 2000 E	4800	10/20/30	1,284	5,70	57	90	
SMART G 2500 E	5600	10/20/30	1,498	6,65	58	96	
SMART G 3000 E	6400	10/20/30	1,712	7,60	59	109	
SMART ECG 1000 E	2700	5/10/15	0,213	1,86	59	46	
SMART ECG 1500 E	3600	7,5/15/22,5	0,284	2,48	60	68	
SMART ECG 2000 E	5400	10/20/30	0,426	3,72	61	90	
SMART ECG 2500 E	6300	10/20/30	0,497	4,34	62	96	
SMART ECG 3000 E	7200	10/20/30	0,568	5,96	63	109	

**WATER HEATED**

Model	Airflow m³/h	P86			P64			P54			Current Fans A	Noise Level (5m) dB(A)	Weight kg
		Heating Capacity 80/60°C kW	Water Drop Pressure 80/60°C Pa	Heating Capacity 60/40°C kW	Water Drop Pressure 60/40°C Pa	Heating Capacity 50/40°C kW	Water Drop Pressure 50/40°C Pa	Power Fans 230V-50Hz kW					
SMART M 1000 P	1660	9,17	880	8,56	4370	8,52	1220	0,428	1,90	54	39		
SMART M 1500 P	2490	14,26	760	13,69	6460	14,34	4480	0,642	2,85	55	58		
SMART M 2000 P	3320	20,65	1930	18,26	4790	18,65	2060	0,856	3,80	56	73		
SMART M 2500 P	4150	26,92	3810	22,12	3850	24,32	4040	1,070	4,75	57	79		
SMART M 3000 P	4980	33,24	6590	28,37	6760	29,77	5660	1,280	5,70	58	91		
SMART ECM 1000 P	1720	9,38	920	8,77	4560	8,74	1280	0,142	1,24	54	39		
SMART ECM 1500 P	2580	14,58	790	14,02	6730	14,71	4690	0,213	1,86	55	58		
SMART ECM 2000 P	3440	21,12	2010	18,70	4990	19,13	2150	0,284	2,48	56	73		
SMART ECM 2500 P	4300	27,53	3960	23,33	4010	24,95	4230	0,355	3,10	57	79		
SMART ECM 3000 P	5160	40,00	6860	29,05	7050	30,54	5920	0,426	3,72	58	91		
SMART G 1000 P	2250	11,04	1230	10,42	6190	10,56	1790	0,642	2,85	55	44		
SMART G 1500 P	3000	16,02	940	15,47	8020	16,37	5670	0,856	3,80	56	64		
SMART G 2000 P	4500	24,92	2700	22,29	6810	23,15	3030	1,284	5,70	57	83		
SMART G 2500 P	5250	31,16	4930	26,61	5060	28,76	5450	1,498	6,65	58	87		
SMART G 3000 P	6000	37,35	8110	32,10	8410	34,03	7180	1,712	7,60	59	99		
SMART ECG 1000 P	2550	11,89	1400	11,27	7110	11,50	2090	0,213	1,86	59	44		
SMART ECG 1500 P	3400	17,29	1070	16,77	9240	17,86	6620	0,284	2,48	60	64		
SMART ECG 2000 P	5100	26,86	3080	24,14	7850	25,24	3530	0,426	3,72	61	83		
SMART ECG 2500 P	5950	33,63	5650	28,84	5840	31,38	6360	0,497	4,34	62	87		
SMART ECG 3000 P	6800	40,34	9290	34,81	9710	37,16	8400	0,568	5,96	63	99		

Water heated: connection pipes P86 and P64 are 2x3/4" female, P54 2x1" male. P86 2 rows coil, P64 3 rows coil, P54 4 rows coil.



**Dimensions**

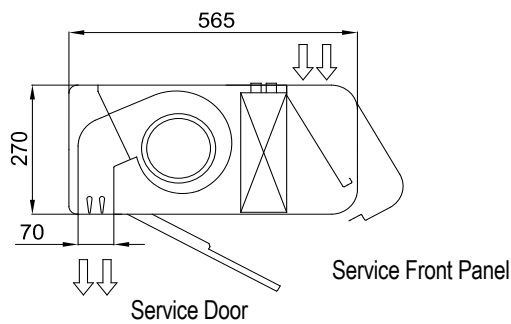
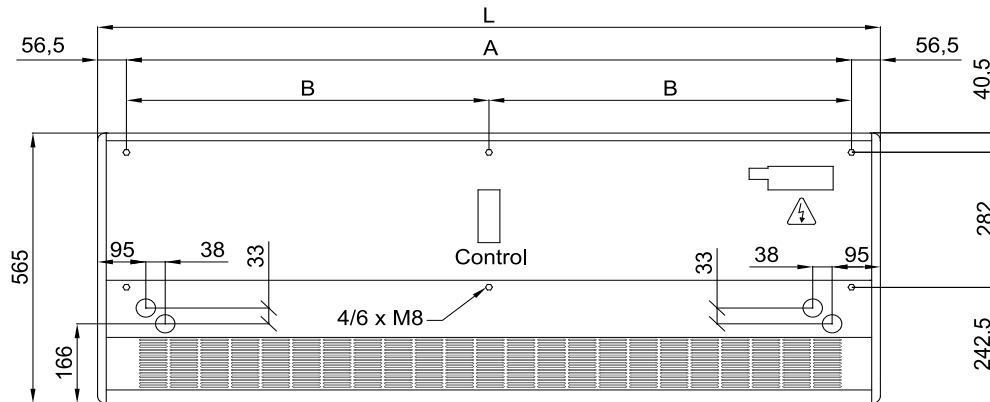

	L	A	B
SMART 1000	1034	920	-
SMART 1500	1534	1420	710
SMART 2000	2034	1920	960
SMART 2500	2534	2420	1210
SMART 3000	3034	2920	1460

**Finishes and details**

