

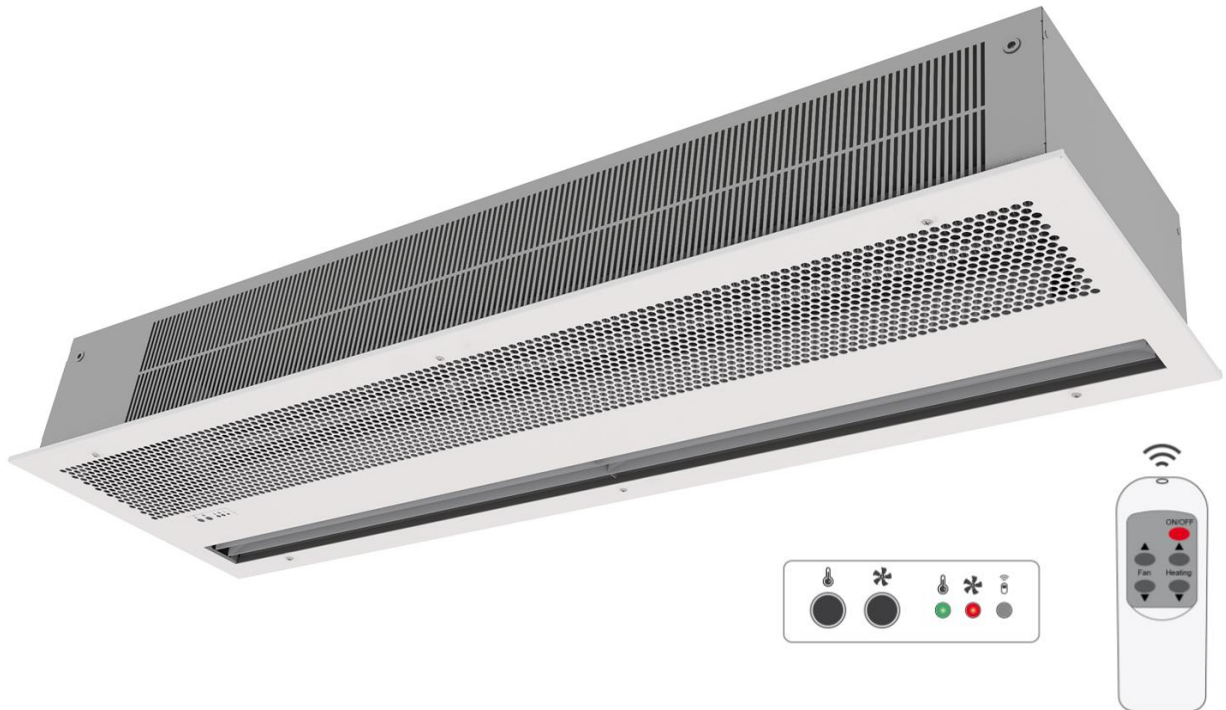

## INSTALLATION, OPERATION AND MAINTENANCE MANUAL



## Air curtain RECESSED OPTIMA WIRELESS



*Read instructions carefully before attempting installation.  
Deliver this manual to end user.*

### SECURITY ADVISE SYMBOLS



*Attention, Danger, Safety Advice!*



*Danger from electric current or high voltage!*



*Injuries risk!*



*Danger! Do not stay underneath: Heavy load.*



*Important information.*

## INDEX

CONNECTION DIAGRAM.....	3
INSTALLATION .....	4
Power Supply .....	5
Fixing.....	5
Electrical elements .....	5
STORAGE AND TRANSPORT .....	5
WORKING INSTRUCTIONS .....	6
Control PCBoard characteristics .....	6
Controller's common characteristics .....	6
Common characteristics to all controllers for electrical heated air curtains .....	6
Remote control characteristics.....	7
WIRING DIAGRAMS .....	7
DATASHEET .....	15
MAINTENANCE INSTRUCTIONS .....	16
External cleaning.....	16
Internal cleaning.....	16
REPAIRS AND REPLACEMENTS .....	17
Motor or turbine replacement.....	17
Fuse replacement .....	18
PCB Button replacement.....	18
PCB replacement .....	19
Heater exchanger replacement.....	20
ACCESSORIES .....	20
DECLARATION OF CONFORMITY .....	21
Air curtain identification .....	22
GUARANTEE .....	22

# CONNECTION DIAGRAM

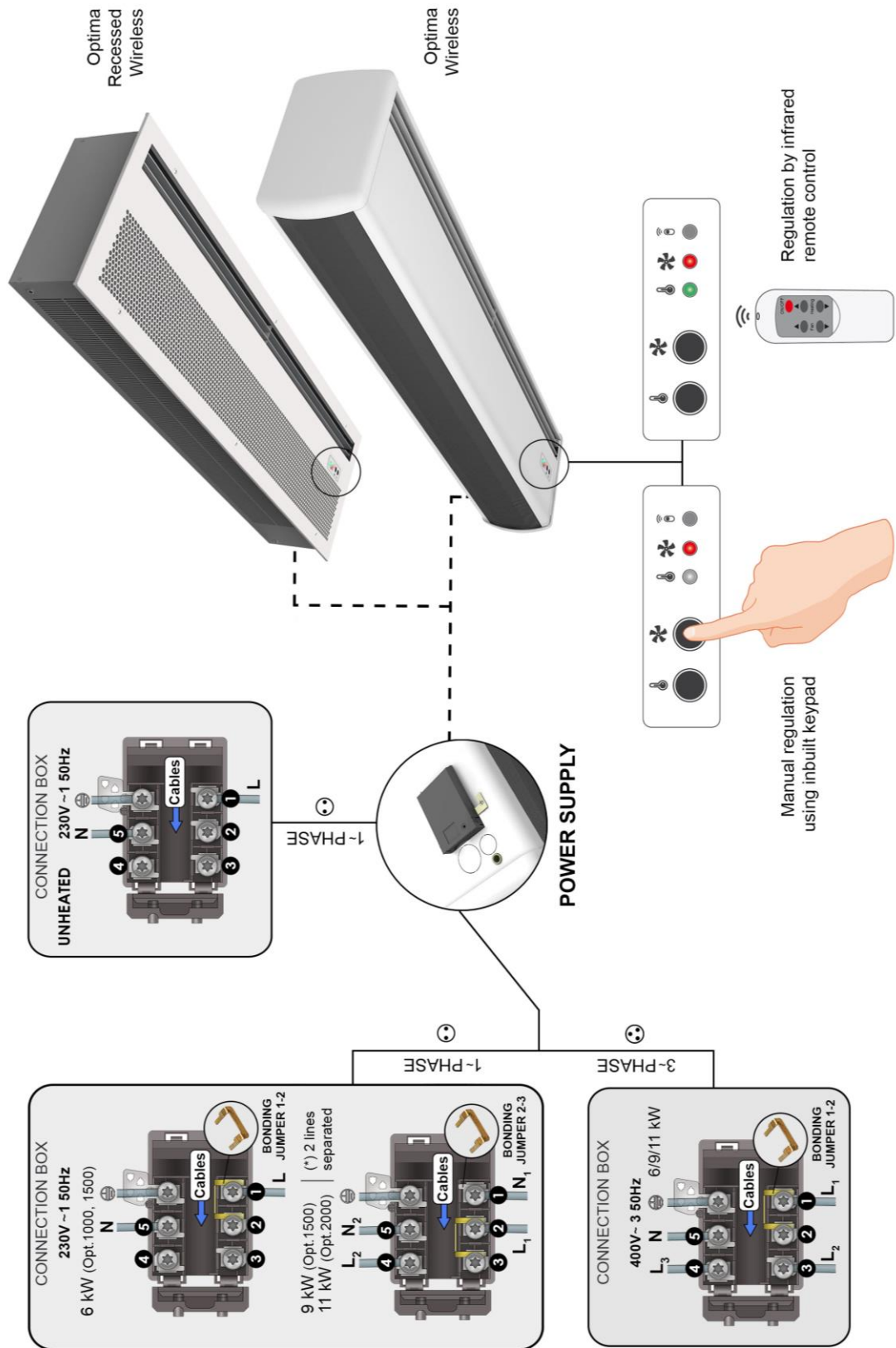

## INSTALLATION

Valid for models: **Recessed Optima Wireless**

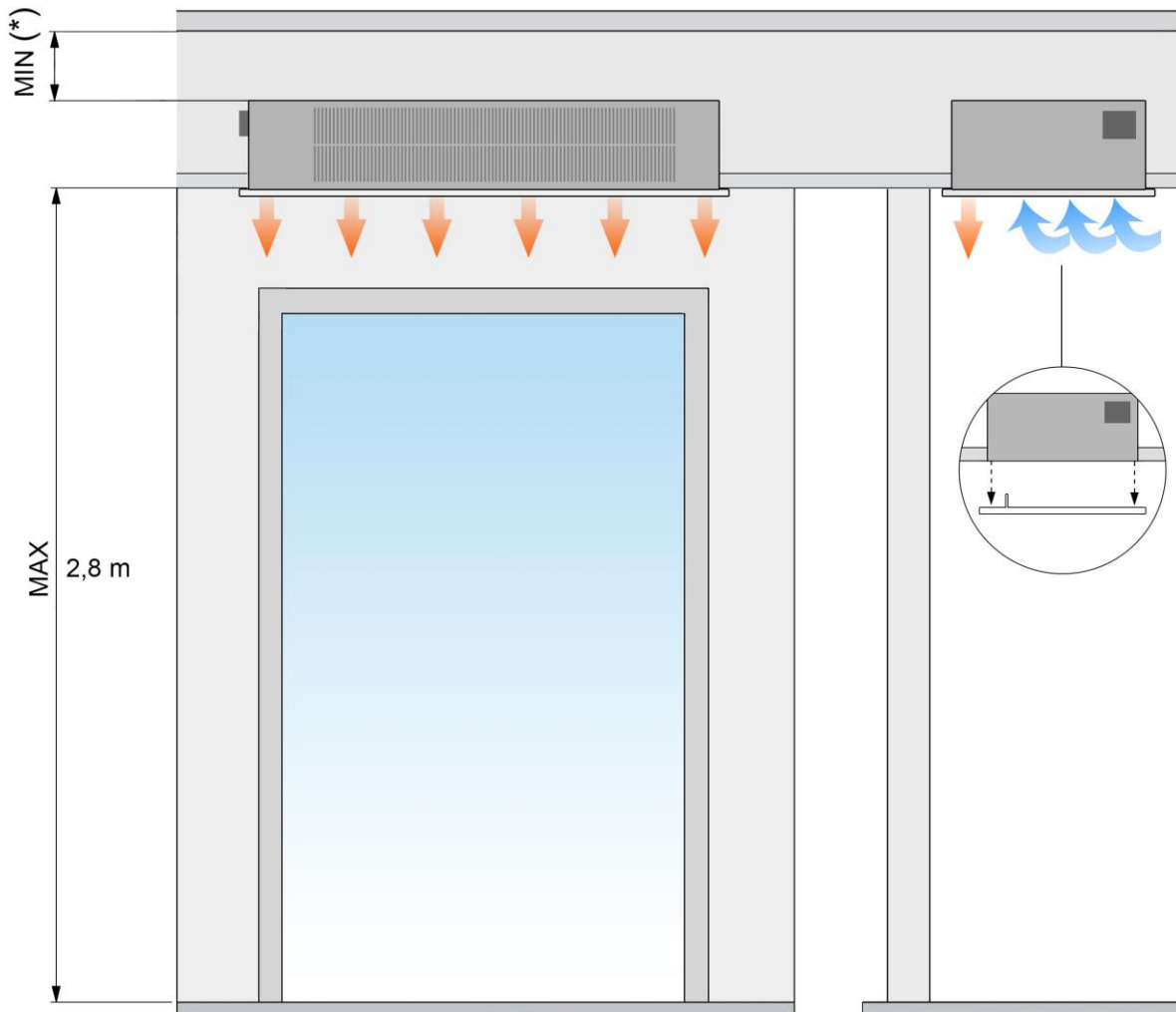

MAX. Maximum recommended height, MIN. Minimum recommended distance

(\*) Unheated units or electrical heated = 1cm. Units with water heating = 10cm

Minimum recommended distance between the inlet grille and any obstacle is the necessary to open the service grille.

	<p><b><i>Installation work, connection, disconnection, electrical wiring, mechanical maintenance and service must be done by qualified people observing these instructions and in accordance with all applicable norms and standards.</i></b></p> <p><b><i>If the unit is operated with additional controller, please consider its specific instructions.</i></b></p>
	<p><b><i>There is no need to open the service door to connect the air curtain. All connections (power supply, control, water pipes when existing) and fixations are external. They are placed on top or lateral of the units. See how to open service door at repairs section.</i></b></p>
	<p><b><i>For safety, the air curtains never have to be stopped by disconnecting them from the main supply, always through the controller and waiting 10 minutes at least to disconnect the main supply. In case of not follow these instructions, the internal parts of the air curtain can be damaged.</i></b></p>

### **Power Supply**

To connect the power supply there is a black connection box outside the air curtain (located on lateral side).

For an ambient air, just connect the single phase 230Vx1.

In case of an air curtain with electrical heating we will also connect the three phase 400Vx3 of the electrical element.

### **Fixing**

Units are provided of several external suspension points, depending on the weight and length of each model (see exact situation of the points at the air curtains characteristics page).

The fixing of the air curtain should be managed according to the weights of each unit shown on the technical data page. The installation can be made through threaded rods, cable tensors or other supports.

See available supports in the accessories section.

### **Electrical elements**

The heater element has 3 or 6 resistances bars (depending on the model) that combined give 2 power stages. The control is managed by 2 PRBEO of 2 and 1 bars (in case of 3 resistances), or 4 and 2 bars (in case of 6 resistances).

## **STORAGE AND TRANSPORT**



**Attention! Heavy load.**

**Do not step underneath hanging load during the transport or assembly.**

Store in a dry place and weather protected in its original packaging. In case the packing is opened, cover the air curtain to protect it from dust. Do not step or put heavy load over the package to avoid damages to the material. Store temperatures are between -20°C and +40°C.

When carrying material, make sure it is not damaged by the forklift (fork penetration in the packaging). Please see the *Packaging* instructions.

## WORKING INSTRUCTIONS



**For safety, the air curtains never have to be stopped by disconnecting them from the main supply, always through the controller and wait for 10 minutes at least to disconnect the main supply. In case to not follow these instructions, the internal parts of the air curtain can be damaged.**

### Control PCBoard characteristics

The PCBoard relays adjust the 2 ventilation and heating speed in case of electrical heated air curtains.

### Controller's common characteristics

- **Controllers:** There is an inbuilt keypad controller placed in the service door, which allows to switch the fan speed and the power stage of the electrical element.
- **2 ventilation speed.**
- **Remote control:** All the standard controllers have an IR receiver that works by infrared.

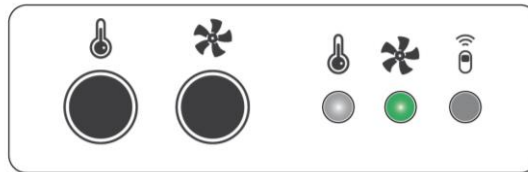

Unheated air curtains controller

### Common characteristics to all controllers for electrical heated air curtains

2 speed system with 2 different Fan Speed and Heating Stages (H1, H2).

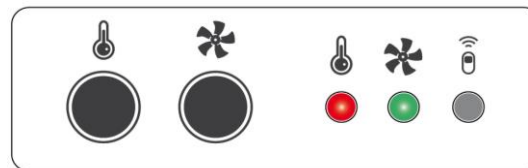

Controller for electrical heated air curtains

- **Two heating stages:** On the first heating stage a green LED turns on, and on the second stage the LED becomes red.
- **Thermal Limitation:** to work the heating there must be any ventilation speed selected, what allow us to choose the maximum heating capacity with the minimum ventilation.
- **Time of delay:** When the equipment is stopped, and it has been working, the electrical heater is still heating during several minutes by thermal inertia with the consequent increase of internal temperature. In order to avoid internal damages by overheating, when we stop the air curtain, it keeps turned on for a period of time.

The air speed and the heating stage are indicated by a lighted LED while the safety function is indicated by a flashing LED.

### Remote control characteristics

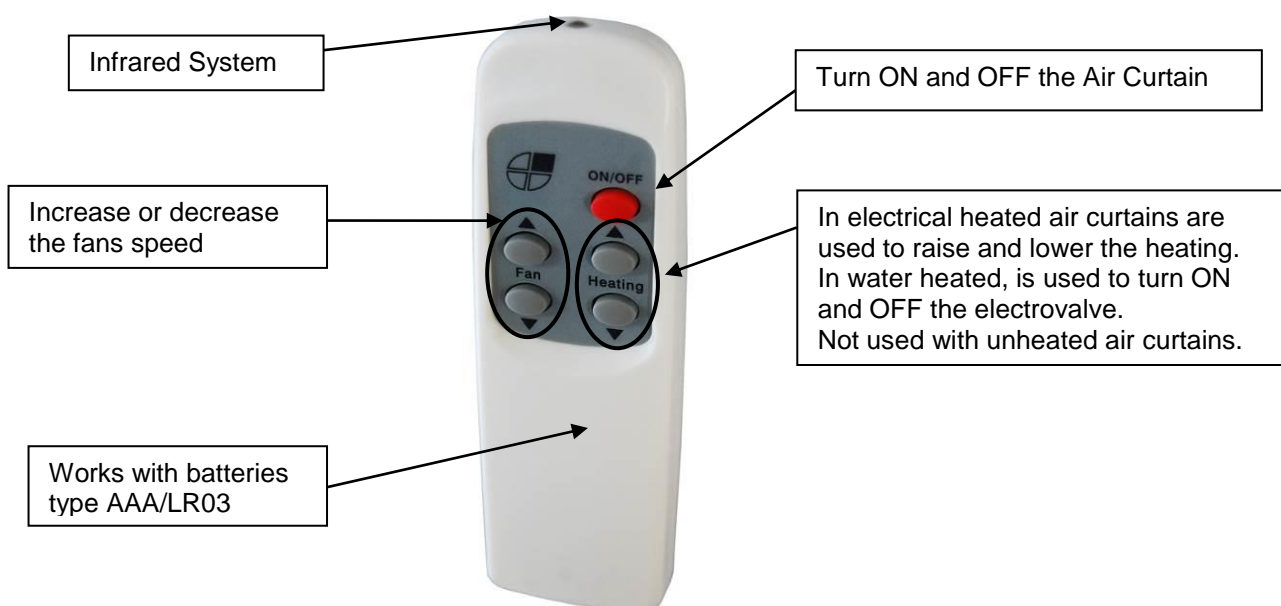

### WIRING DIAGRAMS

Following wiring diagrams are enclosed:

For the following models: OPTIMA RECESSED WIRELESS 1000 - 1500

- Only air with standard controller. Diagram: AIRDOE07900
- Electrical 400Vx3 1000E6kW - 1500E6-9kW with standard controller. Diagram: AIRDOE07910
- Electrical 230Vx1 1000 - 1500E6kW with standard controller. Diagram: AIRDOE07920
- Electrical 230Vx1 1500E9kW with standard controller. Diagram: AIRDOE07925

For the following models: OPTIMA RECESSED WIRELESS 2000

- Only air with standard controller. Diagram: AIRDOE07950
- Electrical 400Vx3 2000E with standard controller. Diagram: AIRDOE07960
- Electrical 230Vx1 2000E with standard controller. Diagram: AIRDOE07965

In case you need to connect the equipment to a PLC, the corresponding wiring diagrams will be supplied.

Control remoto  
Remote control

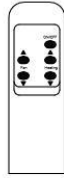

Q= Interruptor magnetotérmico  
Q= Circuit breaker

230Vx1 / 50Hz

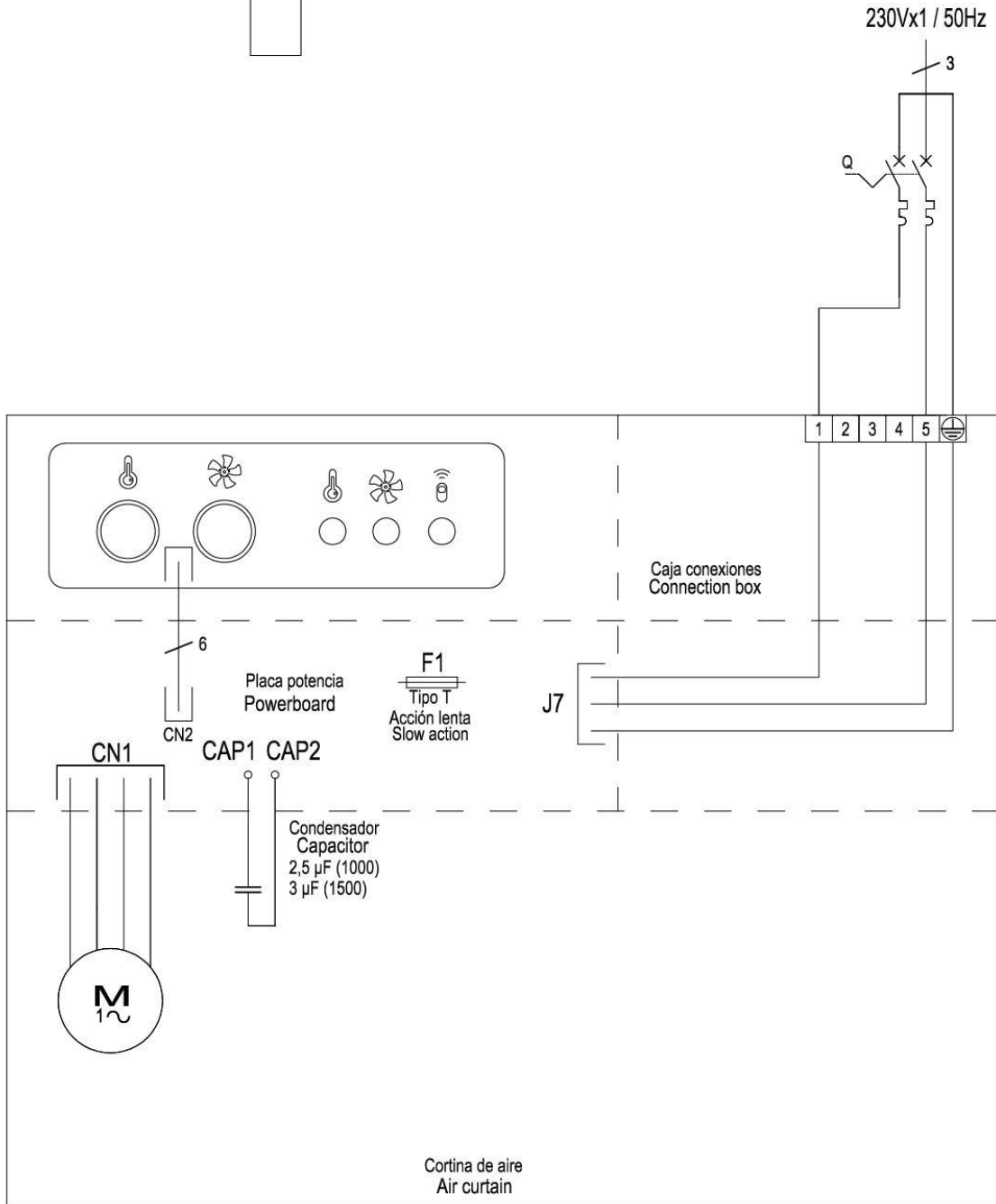

ESQUEMA ELÉCTRICO CORTINA DE AIRE  
WIRING DIAGRAM OF AIR CURTAIN

CONTROLADOR 2 VELOCIDADES, CORTINA SOLO AIRE OPTIMA WIRELESS 1000/1500  
AIR ONLY AIR CURTAIN, 2 SPEEDS OPTIMA WIRELESS 1000/1500

Pág./ Page 1 de/ of 1  
Doc. AIRDOE07900  
R12 - 08/02/16



Control remoto  
Remote control

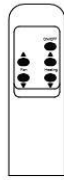

Q= Interruptor magnetotérmico  
Q= Circuit breaker

230Vx1 / 50Hz

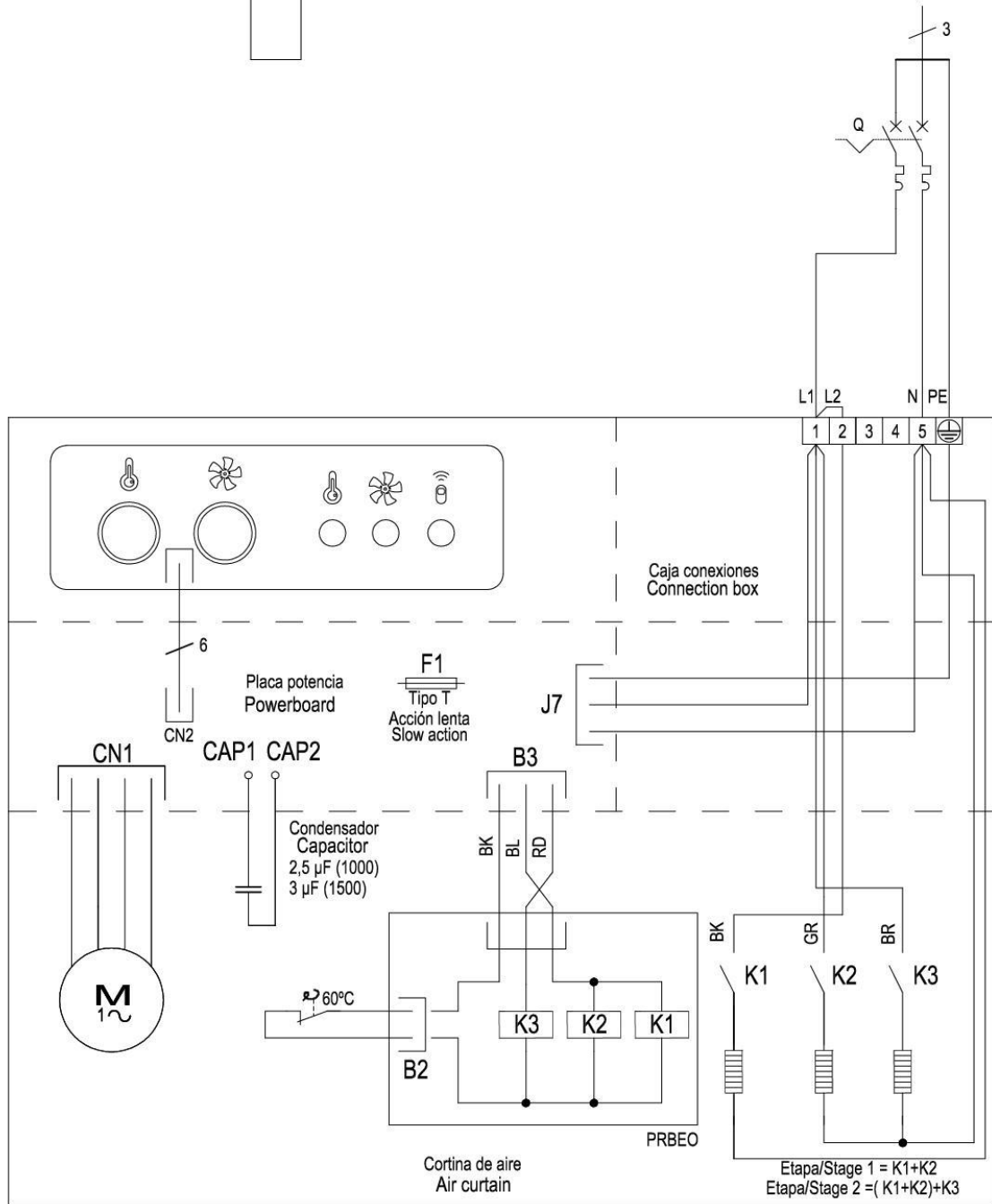

BK	Negro/ Black	RD	Rojo/ Red	BR	Marrón/Brown
BL	Azul/ Blue	GR	Gris/ Grey		

ESQUEMA ELÉCTRICO CORTINA DE AIRE  
WIRING DIAGRAM OF AIR CURTAIN

CONTROLADOR 2 VELOCIDADES, CORTINA SOLO AIRE 230V~1 1000-6kW /1500-6kW  
ELECTRICAL, 2 SPEEDS 230V~1 1000-6kW /1500-6kW

Pág./ Page 1 de/ of 1  
Doc. AIRDOE07920  
R13 - 15/12/16

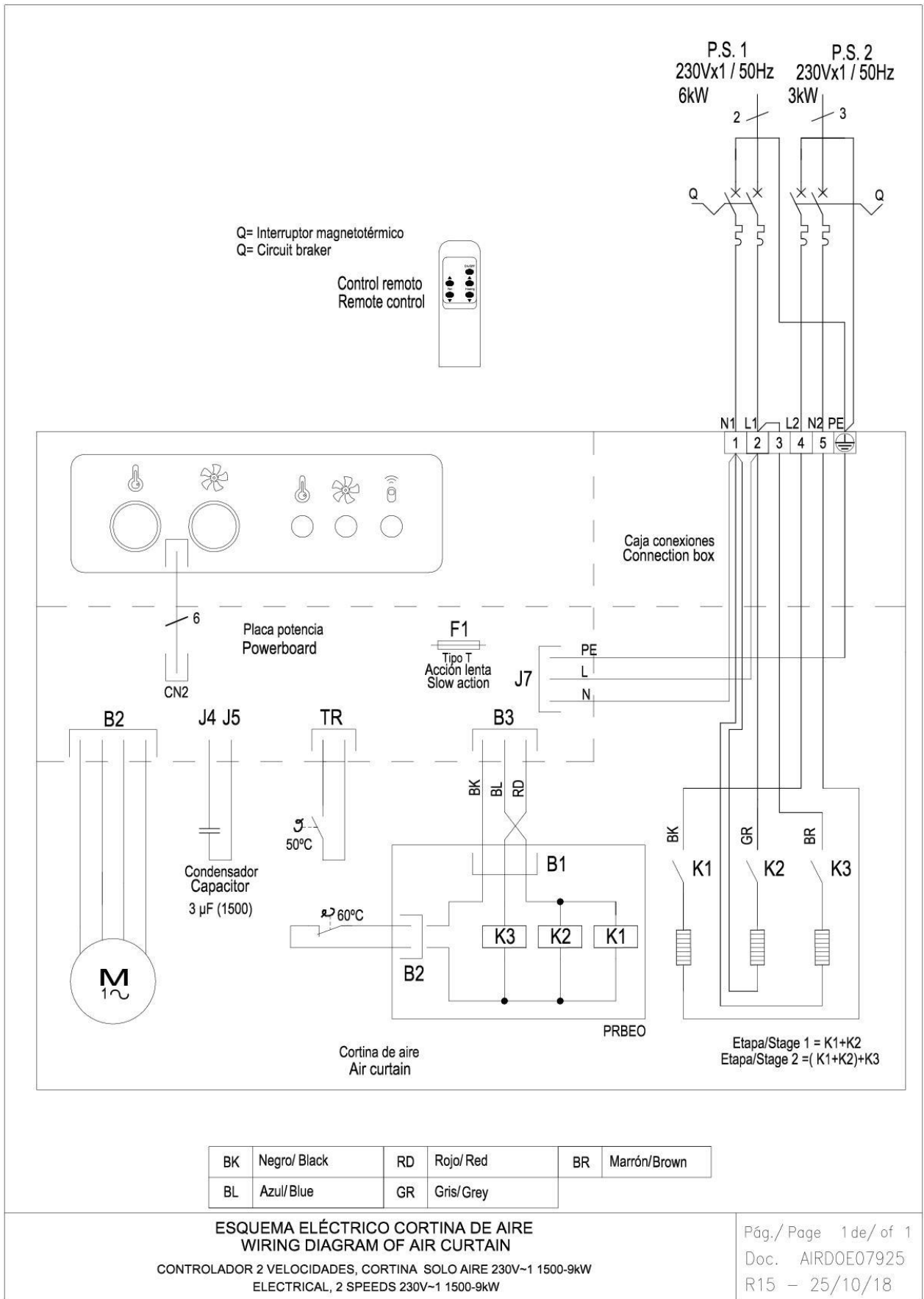

Control remoto  
Remote control



Q= Interruptor magnetotérmico  
Q= Circuit breaker

230Vx1 / 50Hz

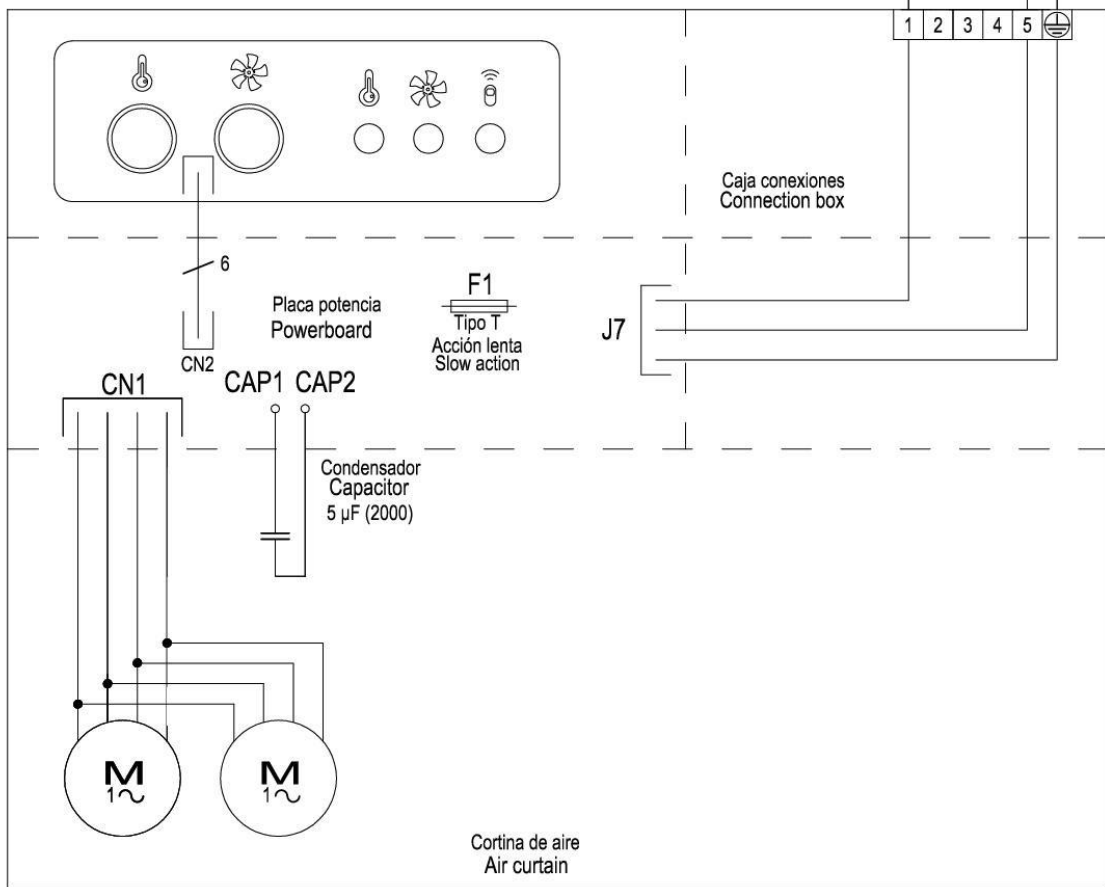
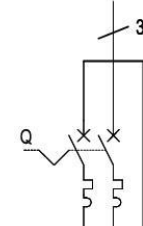

ESQUEMA ELÉCTRICO CORTINA DE AIRE  
WIRING DIAGRAM OF AIR CURTAIN  
CONTROLADOR 2 VELOCIDADES, CORTINA SOLO AIRE OPTIMA WIRELESS 2000  
AIR ONLY, 2 SPEEDS OPTIMA WIRELESS 2000

Pág./ Page 1 de/ of 1  
Doc. AIRDOE07950  
R12 - 08/02/16

Q= Interruptor magnetotérmico  
Q= Circuit breaker

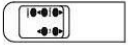

Control remoto  
Remote control

400Vx3 / 50Hz

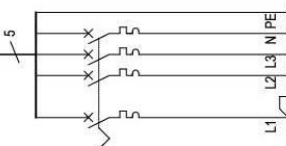

Caja conexiones  
Connection box

Placa potencia  
Powerboard

F1  
tipo  
Acción lenta  
Slow action

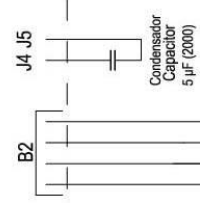
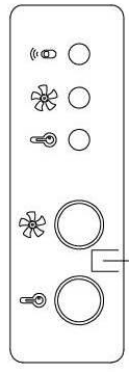

Cortina de aire  
Air curtain

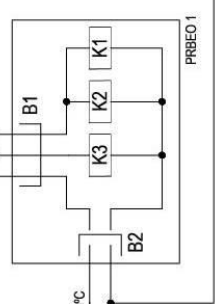
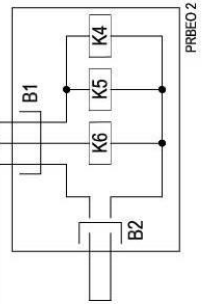

Etapa/Stage 1 = K1+K2+K3  
Etapa/Stage 2 = K1+K2+K3+K4+K5+K6

Negro/Black	RD	Rojol/Red	BR	Marrón/Brown
Azul/Blue	GR	Gris/Grey		

ESQUEMA ELÉCTRICO CORTINA DE AIRE  
WIRING DIAGRAM OF AIR CURTAIN  
CONTROLADOR 2 VELOCIDADES, CORTINA ELÉCTRICA OPTIMA WIRELESS 2000 400V-3 11,3kW  
ELECTRICAL, 2 SPEEDS 400V-3 OPTIMA WIRELESS 2000-11,3kW

Q= Interruptor magnetotérmico  
Q= Circuit breaker

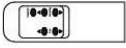

Control remoto  
Remote control

P.S.1  
230Vx1 / 50Hz

P.S.2  
230Vx1 / 50Hz

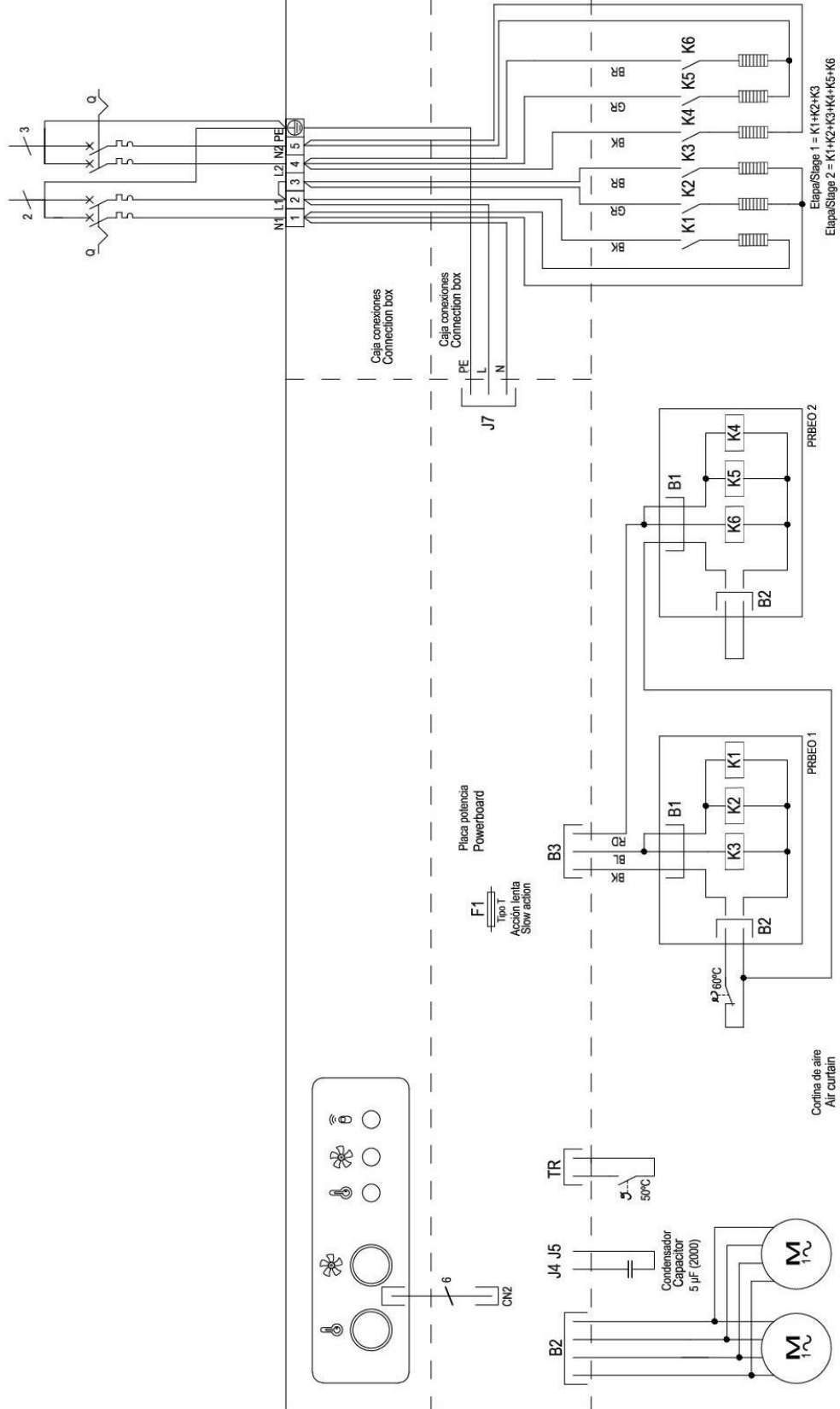

Negro/Black	RD	Rojol/Red	BR	Marrón/Brown
Azul/Blue	GR	Gris/Grey		

ESQUEMA ELÉCTRICO CORTINA DE AIRE  
WIRING DIAGRAM OF AIR CURTAIN

CONTROLADOR 2 VELOCIDADES, CORTINA ELÉCTRICA OPTIMA WIRELESS 2000 230V-1 11,3kW  
ELECTRICAL, 2 SPEEDS OPTIMA WIRELESS 230V-11,3kW

**RECESSED OPTIMA WIRELESS** | Recessed Air Curtains For Commercial Doors



Characteristics



- Self-supporting casing construction made of galvanized steel plate, ready to be installed recessed in a false ceiling.
- Inlet grille panel (free of maintenance) integrated in a single white frame colour white RAL 9016 or black RAL 9005. Other colours are available on request.
- Anodized aluminium outlet vanes, airfoil shaped.
- Low noise twisted cross-flow fans driven by a 2-speed external rotor motor.
- “E” type with electrical shielded elements, two stages with integrated regulation.
- “A” type without heating, air only.
- Included regulation with infrared remote control and inbuilt keypad with leds.

Specifications

AIR ONLY					
Model	Airflow m <sup>3</sup> /h	Power Fans 230V-50Hz W	Current Fans 230V-50Hz A	Noise Level (5 m) dB(A)	Weight kg
RO W 1000 A	1700	80	0,41	35/50	23
RO W 1500 A	2200	117	0,53	36/51	33
RO W 2000 A	3200	160	0,82	38/53	43

ELECTRICAL HEATED								
Model	Airflow m <sup>3</sup> /h	Electrical Heating Capacity kW	Power Supply	Maximum Electrical Heating Current A	Power Fans 230V-50Hz W	Current Fans 230V-50Hz A	Noise Level (5 m) dB(A)	Weight kg
RO W 1000 E	1700	46	400Vx3	8,7	80	0,41	35/50	25
RO W 1000 E230	1700	3,8/5,6	230Vx1	24,5	80	0,41	35/50	25
RO W 1500 E	2200	69	400Vx3	13,0	117	0,53	36/51	36
RO W 1500 E230-6	2200	3,8/5,6	230Vx1	24,5	117	0,53	36/51	36
RO W 1500 E230-9	2200	69	230Vx1 (*)	39,1	117	0,53	36/51	36
RO W 2000 E	3200	5,6/11,3	400Vx3	16,3	160	0,82	38/53	51
RO W 2000 E230	3200	5,6/11,3	230Vx1 (*)	49,1	160	0,82	38/53	51

(\*) 2 separated power supplies.

Dimensions and Finishes

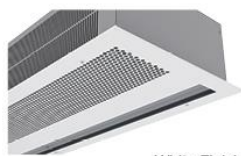

White Finish  
RAL 9016

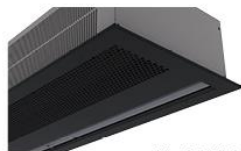

Black Finish  
RAL 9005

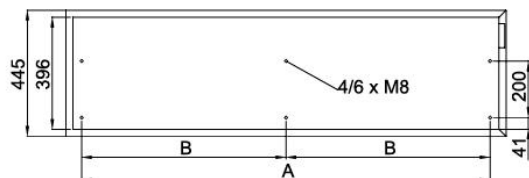
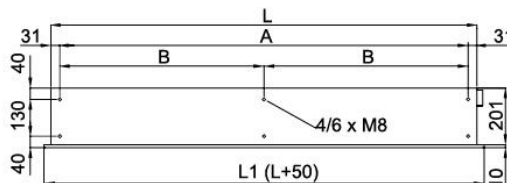
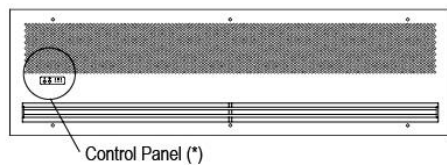

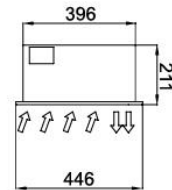

(\*) Manual regulation using inbuilt keypad or by infrared remote control



	L	L1	A	B
RO W 1000	1000	1050	938	-
RO W 1500	1500	1550	1438	-
RO W 2000	2000	2050	1938	969

## MAINTENANCE INSTRUCTIONS

	<b><i>For safety, before any cleaning, disconnect power supply using the controller.</i></b>
	<b><i>It is forbidden to open the service door (risk of electrical discharge and being trapped in fans). Service and maintenance should be done only by introduced and qualified workers.</i></b>
	<b><i>Do not use water or steam for cleaning the internal parts and components of the air curtain.</i></b>

### ***External cleaning***

Air curtains don't need any kind of maintenance except from the cleaning of the casing and the inlet grille. It is recommended to weekly clean the inlet grille. It's important to make sure that the air curtain is OFF, otherwise the dust mixed with a wet cloth would create a kind of paste that will damage the fan rotor when it sucks the air.

Annual cleaning of the discharge area (outlet).

The casing of the air curtain should be cleaned with a wet cloth and non-aggressive detergent. Do not use caustic soap or acids.

The inlet grille prevents the settling of dust and strange objects in the internal elements. It is recommended to check periodically that the inlet grille is free of any object that could interfere the air entrance (plastic bags, papers, etc.).



### ***Internal cleaning***

In models with micro drilled grille is recommended to clean the inside of the unit with a vacuum at least once every two years (\*), best before the winter season, with qualified staff.

(\* ) These periods are indicative, depending on the ambient conditions of every installation.

In places with a high number of particles in suspension is desirable to increase the frequency of the internal cleaning (including the city centers, near construction sites, etc.).

## REPAIRS AND REPLACEMENTS



**Installation and electrical connections must be done by qualified workers and following these instructions.**



**Before any repairs are undertaken, please:**

- **Inform people that there is work in progress.**
- **Disconnect the power supply and protect the thermal magnet (so nobody can restart it accidentally).**
- **Make sure there is no tension in the air curtain.**
- **Make sure the fans are stopped.**
- **Use only original spare parts.**



To **open the inlet grille**, follow these steps:

- Remove the screws of the inlet grille.
- Pull the grille down gently.



### **Motor or turbine replacement**

Before the motor replacement, inform people that there is work in progress. Disconnect main supply, make sure that the unit is without tension and that the fans are stationary.

Remove the lateral of the motor with a screwdriver.

Release the connector of the motor.

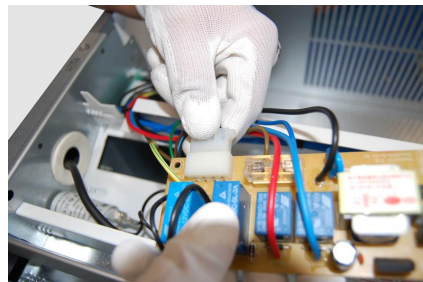

Release the fixation screw of the impeller (Allen L hex key 2.5mm through the discharge opening).

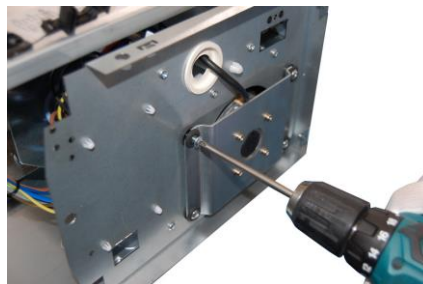

Remove motor loosening the fixation screws. Install the replacement motor following the process in reverse order, making sure that the motor and the turbine fit perfectly, the turbine screw must fit in with the flat part of the motor axle.



### ***Fuse replacement***

---

Before the replacement, inform people that there is work in progress, disconnect main supply, make sure that the unit is without tension and that the fans are stopped.

Open the inlet grille and unplug the visible cable from the plate and the capacitor. The fuse is protected by a plastic box. Pull up the plastic box with the help of a screwdriver and replace the fuse.

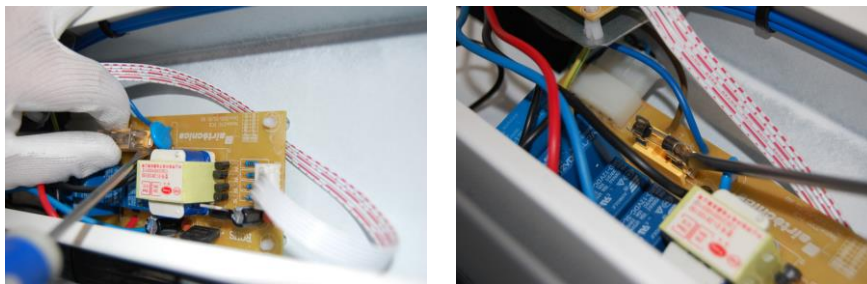

### ***PCB Button replacement***

---

Before the replacement, inform people that there is work in progress, disconnect main supply, make sure that the unit is without tension and that the fans are stationary.

Open the inlet grille and remove the screws of the PCB button support.

Disconnect the connector of the PCB buttons:

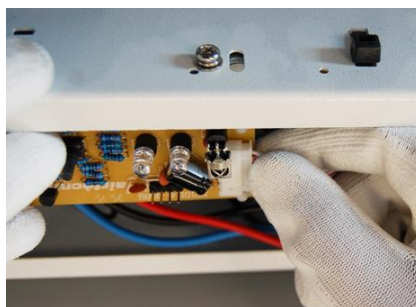

Remove the screws of the PCB button support:

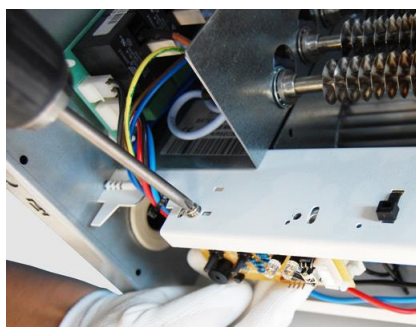

Before to changing the PCB button, disassemble the PCB from the separators using a tool:

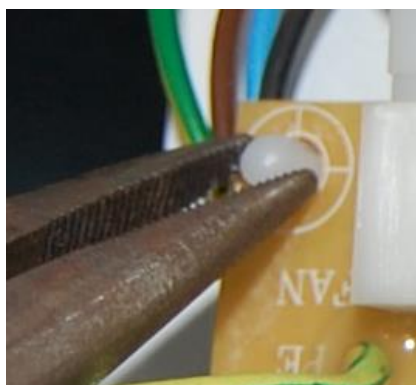

To assemble the new PCB button follow the same process in reverse order.

## PCB replacement

Before the replacement, inform people that there is work in progress, disconnect main supply, and make sure that the unit is without tension and the fans are stationary.

First, open the inlet grille and disconnect the PCB buttons and remove the screws of the support, indicated in the previous section (PCB Button replacement). By doing so, the access to the PCB is clear.

Second, we have to:

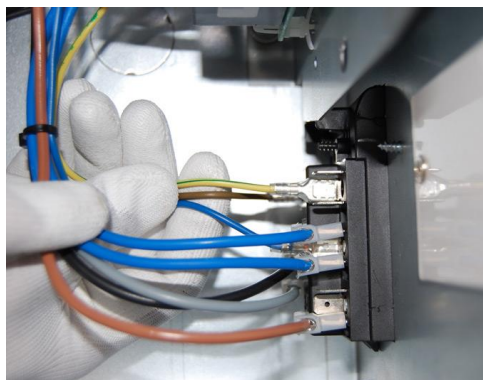

1. Disconnect the power supply of the PCB of the connection box.



2. Disconnect the capacitor.

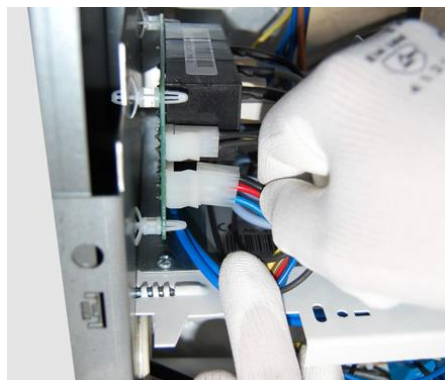

3. Disconnect the connector B1.



4. Disassemble the PCB from the separators using a tool.

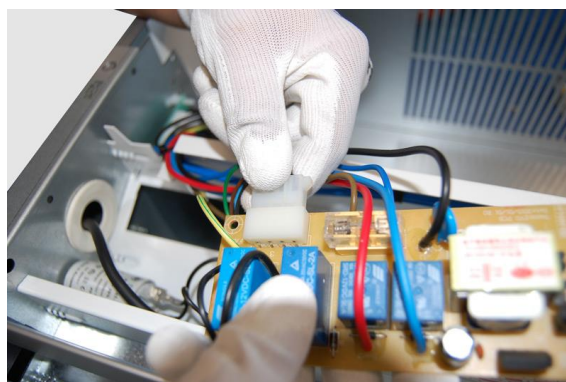

5. Disconnect from the PCB the cable of the motor.

To assemble the new PCB follow the same process in reverse order.

## Heater exchanger replacement

Before changing the heater, inform people that there is work in progress, stop the air curtain through the inbuilt controller and disconnect main supply. Make sure that the unit is without tension and the fans are stationary. Before removing the screws that fix the heater, we have to:



1. Disconnect the bars to the PRBEO removing the connectors.

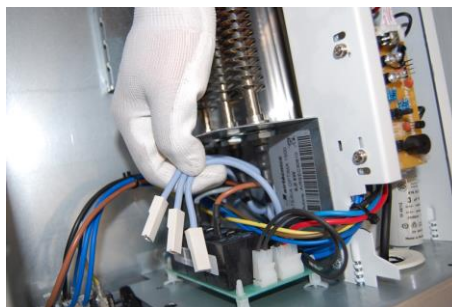

2. Each PRBEO has three cables to remove.

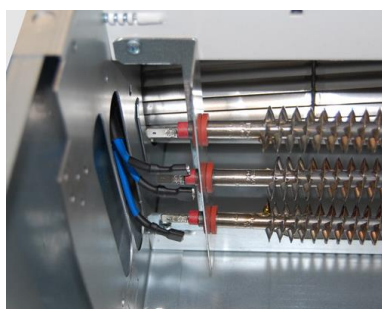

3. At the other side of the heater element, it is necessary to disconnect the cable of each bar.



4. Remove all the fixation screws of the heater supports.



5. Once removed the screws we will proceed to pull out the electrical element using gloves to avoid any cut. To assemble the new heater follow the same process in reverse order.

## ACCESSORIES

Supports, vibration dampers, etc. depending on the model.



DECLARATION OF CONFORMITY



Declaration  of conformity / Declaración  de conformidad

Manufacturer **Motors i Ventiladors S.L. (AIRTECNICS)**  
Fabricante **Conca de Barberà 6, Pol. Ind. Pla de la Bruguera  
08211 Castellar del Vallès (Barcelona) Spain**

We declare, under our sole responsibility, that the product(s)  
*Declaramos, bajo nuestra única responsabilidad, que el/los producto(s)*

**Air Curtains**  
**Cortinas de aire**

with models  
*con los modelos*

**Minibel, Optima, Recessed Optima, Optima Wireless, Recessed Optima  
Wireless, Windbox, Recessed Windbox, Smart, Dam, Deco, Kool, Variwind,  
Rotowind, Invisair, Rund, Zen, Triojet System, Duojet, Max, Recessed Dam,  
Recessed Compact, Maxwell**

is/are developed, designed and manufactured in accordance with the following directive(s)  
*ha(n) sido desarrollado(s), diseñado(s) y fabricado(s) de acuerdo con la(s) siguiente(s) directiva(s)*

**Low Voltage Directive 2014/35/UE**  
**Directiva Baja Tensión 2014/35/UE**

**Electromagnetic Compatibility Directive 2014/30/UE**  
**Directiva Compatibilidad Electromagnética 2014/30/UE**

**Restriction Certain Hazardous Substances Directive 2011/65/EU (RoHS)**  
**Directiva Restricción Substancias Peligrosas 2011/65/EU**

**Eco-design Energy-related Products Directive 2009/125/EC**  
**Directiva Diseño Ecológico Productos Con Energía 2009/125/CE**

applying the following harmonized standards in particular  
*aplicando las siguientes normas armonizadas en particular*

**LVD: EN 60335-1:2012 + AC:2014 + A11:2014  
EN 60335-2-30:2010 + A11:2012**

**EMC: EN 61000-6-2:2006  
EN 61000-6-3:2007 + A1:2012  
EN 55014-1:2008 + A1:2009 + A2:2012  
EN 55014-2:2015**

**RoHS: EN 50581:2012**

Date / Fecha  
Name / Nombre  
Position / Cargo

**25/04/2017**  
**Jordi Oltra Orta**  
**General Manager / Director General**

**AIRTECNICS**  
MOTORS I VENTILADORS S.L.  
B-58967183 - C/ Conca de Barberà, 6  
08211 CASTELLAR DEL VALLES  
Tel. 93 715 99 88 - Fax 93 715 99 89



**Air curtain identification**

Each air curtain is identified by a unique serial number printed in a label located inside the door service. There is also indicated the model and their technical characteristics (flow, fans technical characteristics and power heating).

It is indispensable to have this number to facilitate possible replacements or technical information of the air curtain in question.

<b>Model</b> <i>Modelo</i>	WINDBOX M 2000 E			
<b>Airflow</b> <i>Caudal</i>	3600	m3/h		
<b>Blowers</b> <i>Ventiladores</i>	1,88	A	0,424	kW 230 V/50Hz
<b>Heating capacity</b> <i>Calefacción</i>	80/60 °C		60/40 °C	
<b>Water Coil</b> <i>Agua</i>		kW		kW
<b>Electric Coil</b> <i>Bateria Eléctrica</i>	6/12/18	kW	400V~3 50Hz	
<b>Serial Number</b> <i>Número de Serie</i>	2015-07-06 / 61.990			

**GUARANTEE**

Your air curtain is guaranteed for a period of one year from the date of purchase. We will adjust, repair or replace at our discretion from our warehouse any defect, system failure or part found to be defective. The assembly cost out of our warehouse is at buyer expense. The products that, in our eyes, have been inadequately used, incorrectly manipulated, improperly installed, connected to different nominal tensions, modified, repaired by non-authorized workers or that have suffered damages during transport are totally excluded from the guarantee.

*To validate the guarantee it should be correctly filled and enclosed with the invoice that vouches for the buying date. If it is manipulated, it will lose all validity.*

*It is the buyer's responsibility to take the necessary safety measures because in case of a failure or mistake in one of our products, no damages to third parties, sets or installations will occur.*

**Guarantee draft**

**Air curtains data:**

Model: ..... Series number: .....  
 Invoice date: ..... Invoice number: .....

**Buyer data:**

Name: .....  
 Address: .....  
 Country: ..... Phone: ..... Fax: .....

**Seller data:**

Name: .....  
 Address: .....  
 Country: ..... Phone: ..... Fax: .....

**Buyer signature and stamp**

**Seller signature and stamp**



If you detect an error in this manual, please inform us to improve even more. Airtècnics reserves the right to modify design and specifications without prior notice.