

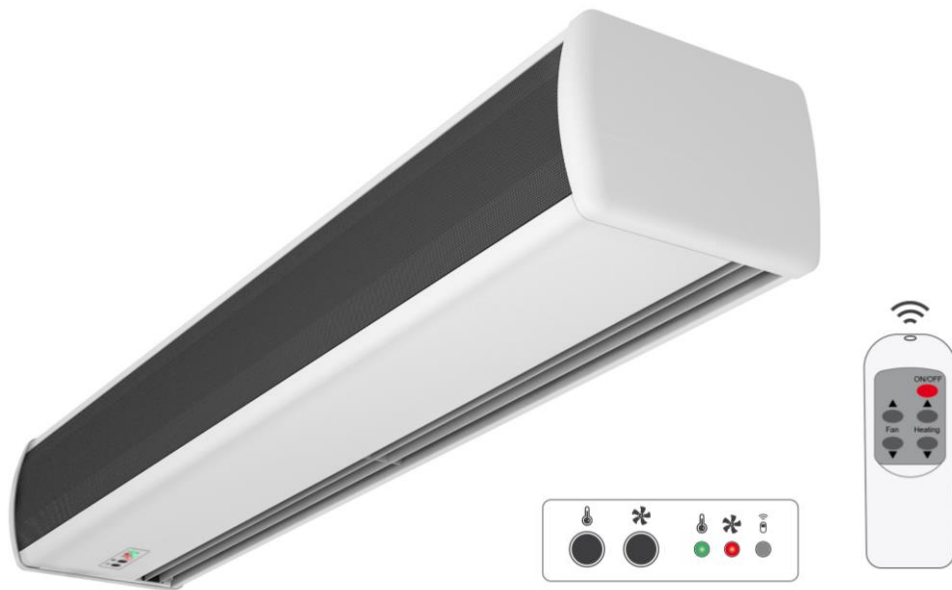

INSTALLATION, OPERATION AND MAINTENANCE MANUAL



Air Curtain OPTIMA WIRELESS

Please, read these instructions carefully before attempting installation

SECURITY ADVISE SYMBOLS



Attention, Danger, Safety Advice!



Danger from electric current or high voltage!



Injuries risk!



Danger! Do not stay underneath: Heavy load.



Important information.

INDEX

CONNECTION DIAGRAM.....	3
INSTALLATION	4
Power Supply	4
Fixing.....	4
Electrical elements	4
STORAGE AND TRANSPORT	5
WORKING INSTRUCTIONS	5
Control PCBoard characteristics.....	5
Controller's common characteristics	5
Common characteristics to all controllers for electrical heated air curtains.....	5
Remote control characteristics.....	6
WIRING DIAGRAMS	6
DATASHEET	14
MAINTENANCE INSTRUCTIONS	15
External cleaning.....	15
Internal cleaning.....	15
REPAIRS AND REPLACEMENTS.....	16
Motor or turbine replacement.....	16
Fuse replacement	16
Plate replacement	16
Heater replacement.....	17
Heat exchanger replacement.....	17
ACCESSORIES.....	17
DECLARATION OF CONFORMITY.....	18
Air curtain identification.....	19
GUARANTEE	19

CONNECTION DIAGRAM

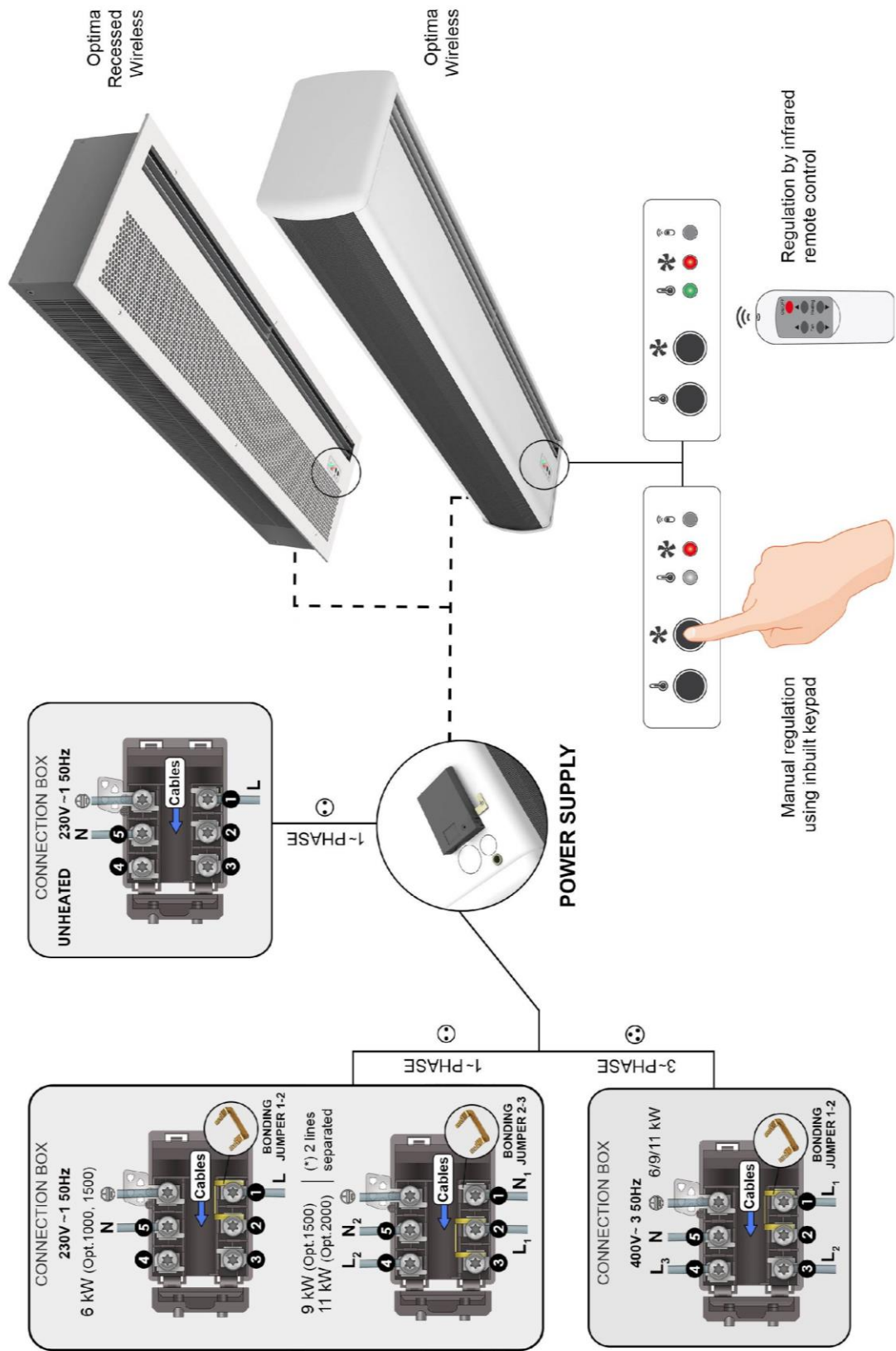

INSTALLATION

Valid for models: **Optima Wireless**

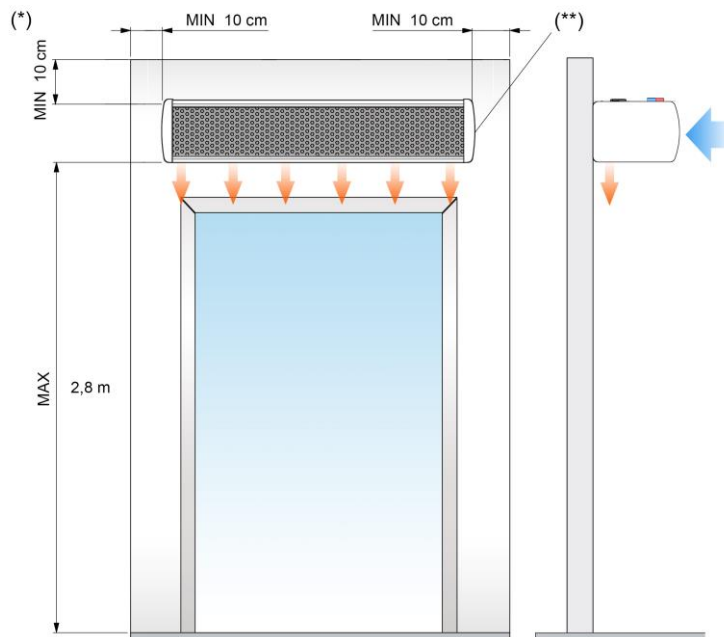

MAX. Maximum recommended height, MIN. Minimum recommended distance

(**) Removable covers

Minimum recommended distance between the inlet grille and any obstacle is of 200mm.

	<p><i>Installation work, connection, disconnection, electrical wiring, mechanical maintenance and service must be done by qualified people observing these instructions and in accordance with all applicable norms and standards.</i></p> <p><i>If the unit is operated with additional controller, please consider its specific instructions.</i></p>
	<p><i>There is no need to open the service door to connect the air curtain. All connections (power supply, control, water pipes when existing) and fixations are external. They are placed on top of the units. See how to open service door at repairs section.</i></p>
	<p><i>For safety, the air curtains never have to be stopped by disconnecting them from the main supply, always through the controller and waiting 10 minutes at least to disconnect the main supply. In case to not follow these instructions, the internal parts of the air curtain can be damaged.</i></p>

Power Supply

To connect the power supply there is a black connection box outside the air curtain (located on top).

For an ambient air, just connect the single phase 230Vx1.

In case of an air curtain with electrical heating we will also connect the three phase 400Vx3 of the electrical element. Optionally under request the power supply of the electrical element can be single phase 230Vx1 depending on each model (special wiring diagram will be enclosed).

Fixing

Units are provided of several external suspension points, depending on the weight and length of each model (see exact situation of the points at the air curtains characteristics page).

The fixing of the air curtain should be managed according to the weights of each unit shown on the technical data page. The installation can be made through threaded rods, cable tensors or other supports. See available supports in the accessories section.

Electrical elements

The heater element has 3 or 6 resistances bars (depending on the model) that combined give 2 power stages. The control is managed by 2 PRBEO of 2 and 1 bars (in case of 3 resistances), or 4 and 2 bars (in case of 6 resistances).

STORAGE AND TRANSPORT



Attention! Heavy load.
Do not step underneath hanging load during the transport or assembly.

Store in a dry place and weather protected in its original packaging. In case the packing is opened, cover the air curtain to protect it from dust. Do not step or put heavy load over the package to avoid damages to the material. Store temperatures are between -20°C and +40°C.

When carrying material, make sure it is not damaged by the forklift (fork penetration in the packaging). Please see the *Packaging* indications.

WORKING INSTRUCTIONS



For safety, the air curtains never have to be stopped by disconnecting them from the main supply, always through the controller and wait for 10 minutes at least to disconnect the main supply. In case to not follow these instructions, the internal parts of the air curtain can be damaged.

Control PCBoard characteristics

The PCBoard relays adjust the 2 ventilation and heating speed in case of electrical heated air curtains.

Controller's common characteristics

- **Controllers:** There is an inbuilt keypad controller placed in the service door, which allows to switch the fan speed and the power stage of the electrical element.
- **2 ventilation speed.**
- **Remote control:** All the standard controllers have an IR receiver that works by infrared.

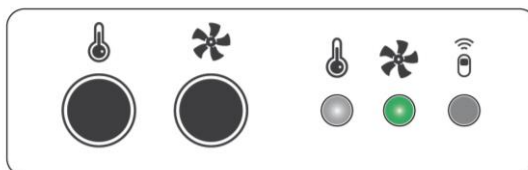

Unheated air curtains controller

Common characteristics to all controllers for electrical heated air curtains

2 speed system with 2 different Fan Speed and Heating Stages (H1, H2).

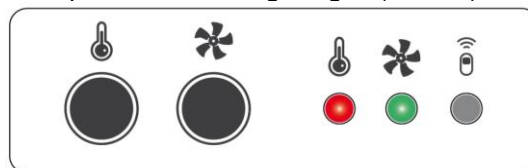

Controller for electrical heated air curtains

- **Two heating stages:** On the first heating stage a green LED turns on, and on the second stage the LED becomes red.
- **Thermal Limitation:** to work the heating there must be any ventilation speed selected, what allow us to choose the maximum heating capacity with the minimum ventilation.
- **Time of delay:** When the equipment is stopped, and it has been working, the electrical heater is still heating during several minutes by thermal inertia with the consequent increase of internal temperature. In order to avoid internal damages by overheating, when we stop the air curtain, it keeps turned on for a period of time.

The air speed and the heating stage are indicated by a lighted LED while the safety function is indicated by a flashing LED.

Remote control characteristics

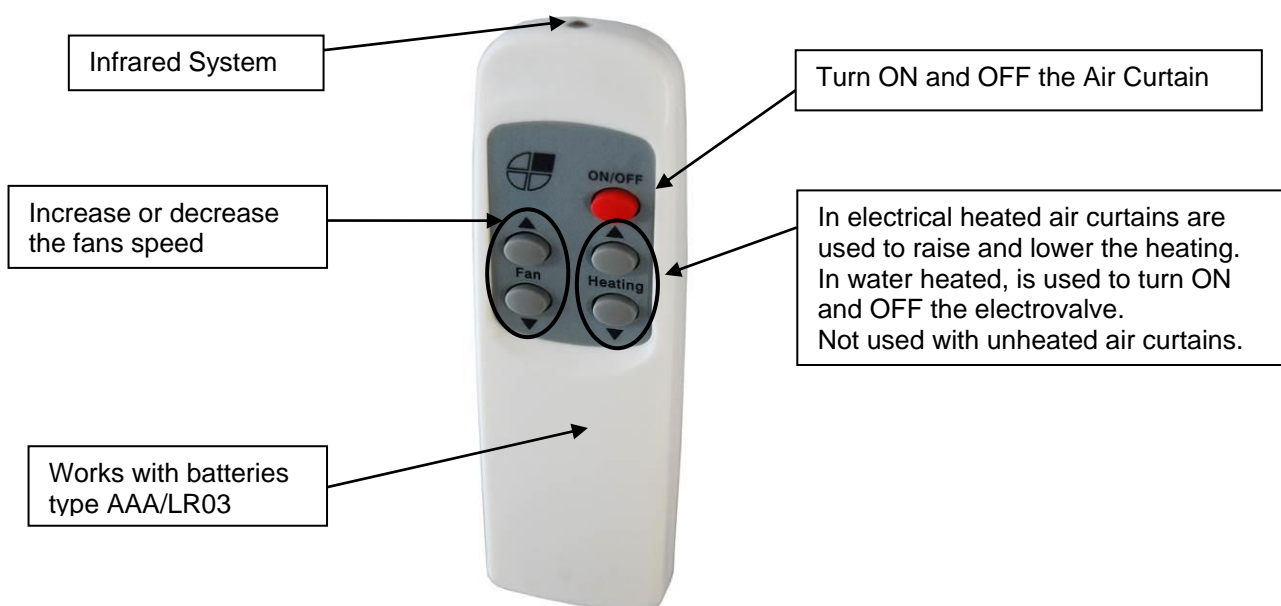

WIRING DIAGRAMS

Following wiring diagrams are enclosed:

For the following models: OPTIMA WIRELESS 1000 - 1500

- Only air with standard controller. Diagram: AIRDOE07900
- Electrical 400Vx3 1000E6kW - 1500E6-9kW with standard controller. Diagram: AIRDOE07910
- Electrical 230Vx1 1000 - 1500E6kW with standard controller. Diagram: AIRDOE07920
- Electrical 230Vx1 1500E9kW with standard controller. Diagram: AIRDOE07925

For the following models: OPTIMA WIRELESS 2000

- Only air with standard controller. Diagram: AIRDOE07950
- Electrical 400Vx3 2000E with standard controller. Diagram: AIRDOE07960
- Electrical 230Vx1 2000E with standard controller. Diagram: AIRDOE07965

In case you need to connect the equipment to a PLC, the corresponding wiring diagrams will be supplied.

Control remoto
Remote control

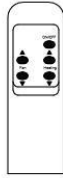

Q= Interruptor magnetotérmico
Q= Circuit breaker

230Vx1 / 50Hz

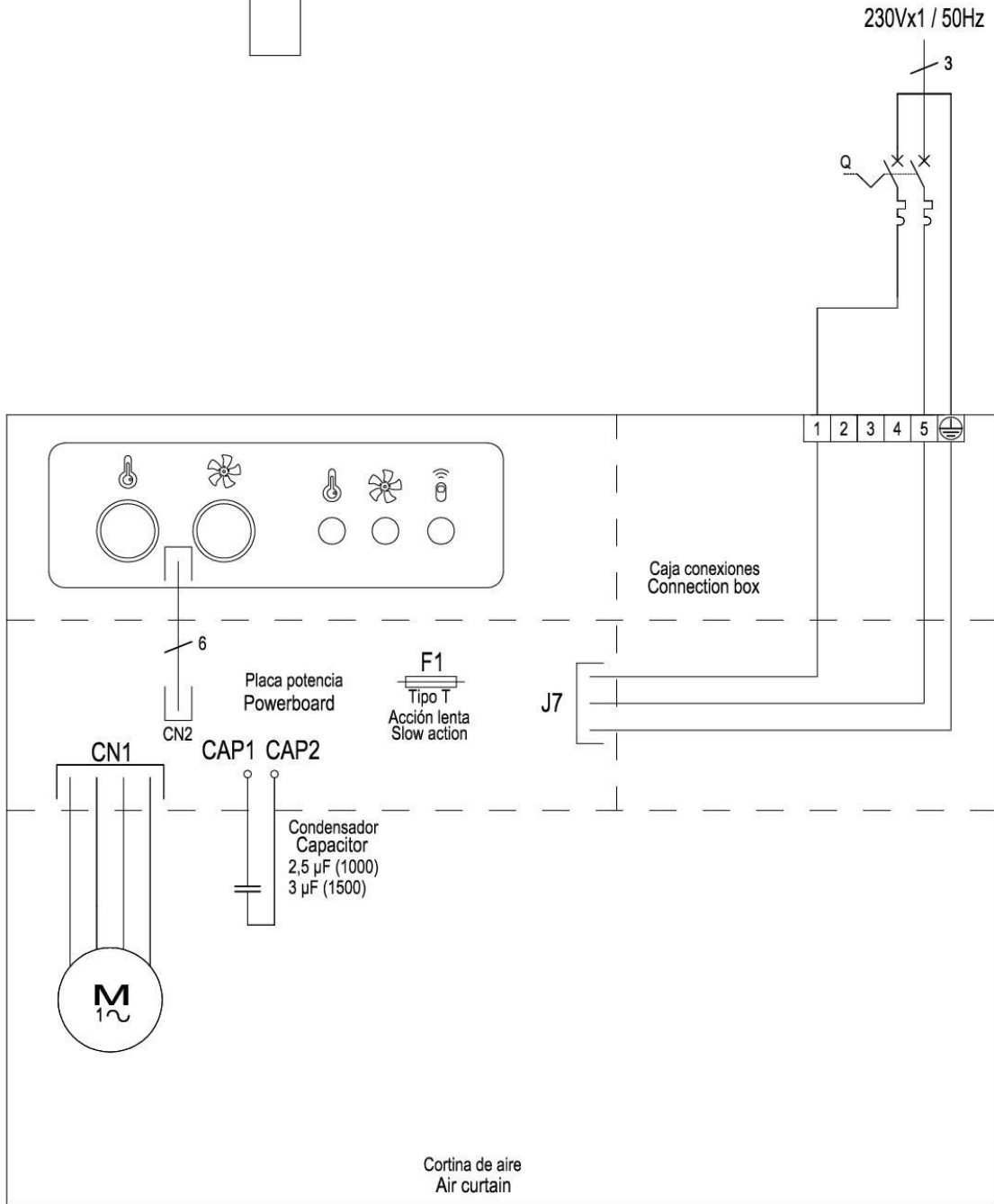

ESQUEMA ELÉCTRICO CORTINA DE AIRE
WIRING DIAGRAM OF AIR CURTAIN

CONTROLADOR 2 VELOCIDADES, CORTINA SOLO AIRE OPTIMA WIRELESS 1000/1500
AIR ONLY AIR CURTAIN, 2 SPEEDS OPTIMA WIRELESS 1000/1500

Pág./ Page 1 de/ of 1
Doc. AIRDOE07900
R12 - 08/02/16

Q= Interruptor magnetotérmico
Q= Circuit breaker

Control remoto
Remote control



400Vx3 / 50Hz

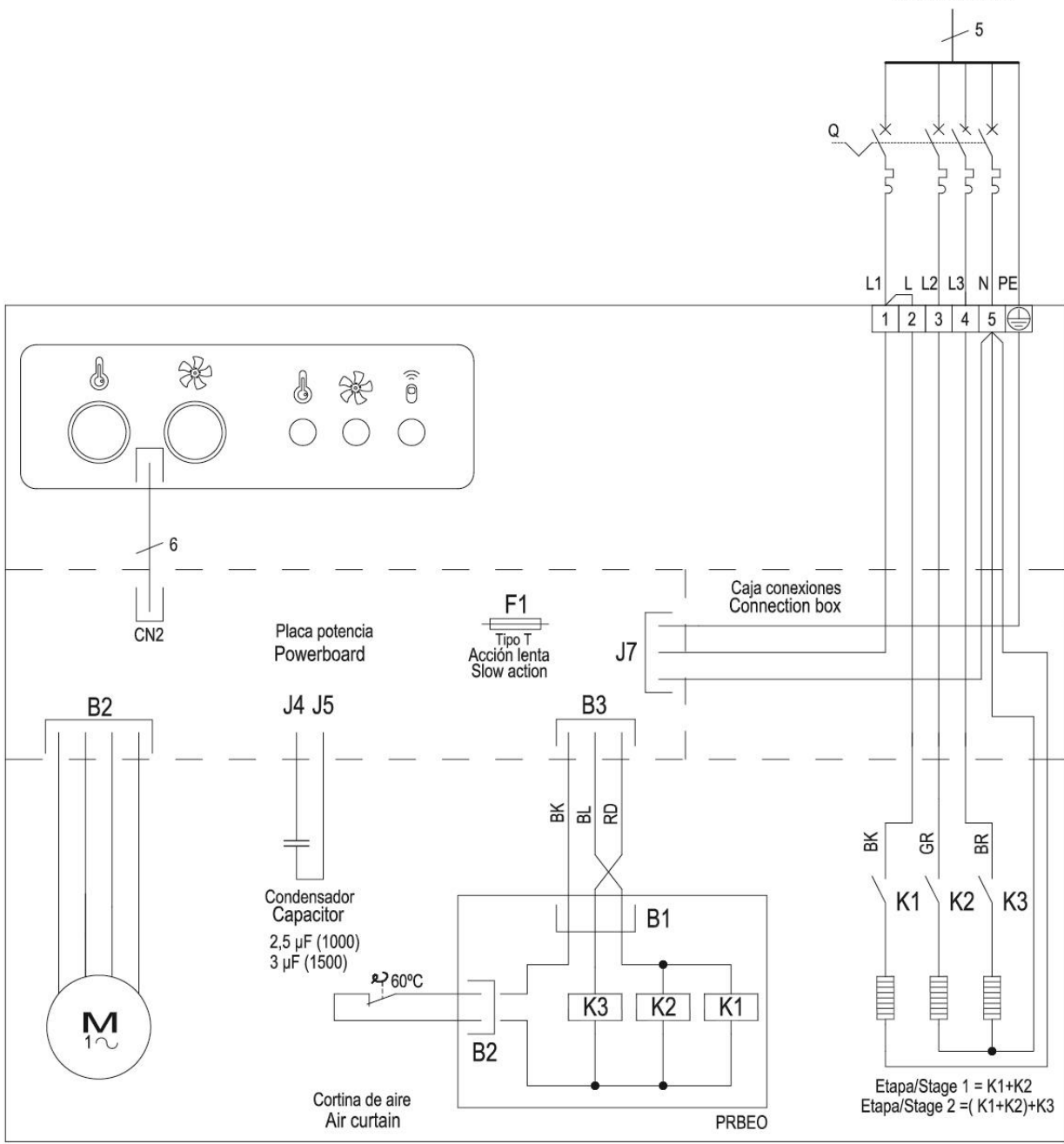

BK	Negro/ Black	RD	Rojo/ Red	BR	Marrón/ Brown
BL	Azul/ Blue	GR	Gris/ Grey		

ESQUEMA ELÉCTRICO CORTINA DE AIRE CONTROLADOR 2 VELOCIDADES
WIRING DIAGRAM OF AIR CURTAIN 2 SPEED CONTROLLER

CORTINA ELÉCTRICA 400V~3 1000-6kW /1500-6-9kW
ELECTRICAL, 2 SPEEDS 400V~3 1000-6kW /1500-6-9kW

Pág./ Page 1 de/ of 1
Doc. AIRDOE07910
R15 - 11/03/20

Control remoto
Remote control



Q= Interruptor magnetotérmico
Q= Circuit breaker

230Vx1 / 50Hz

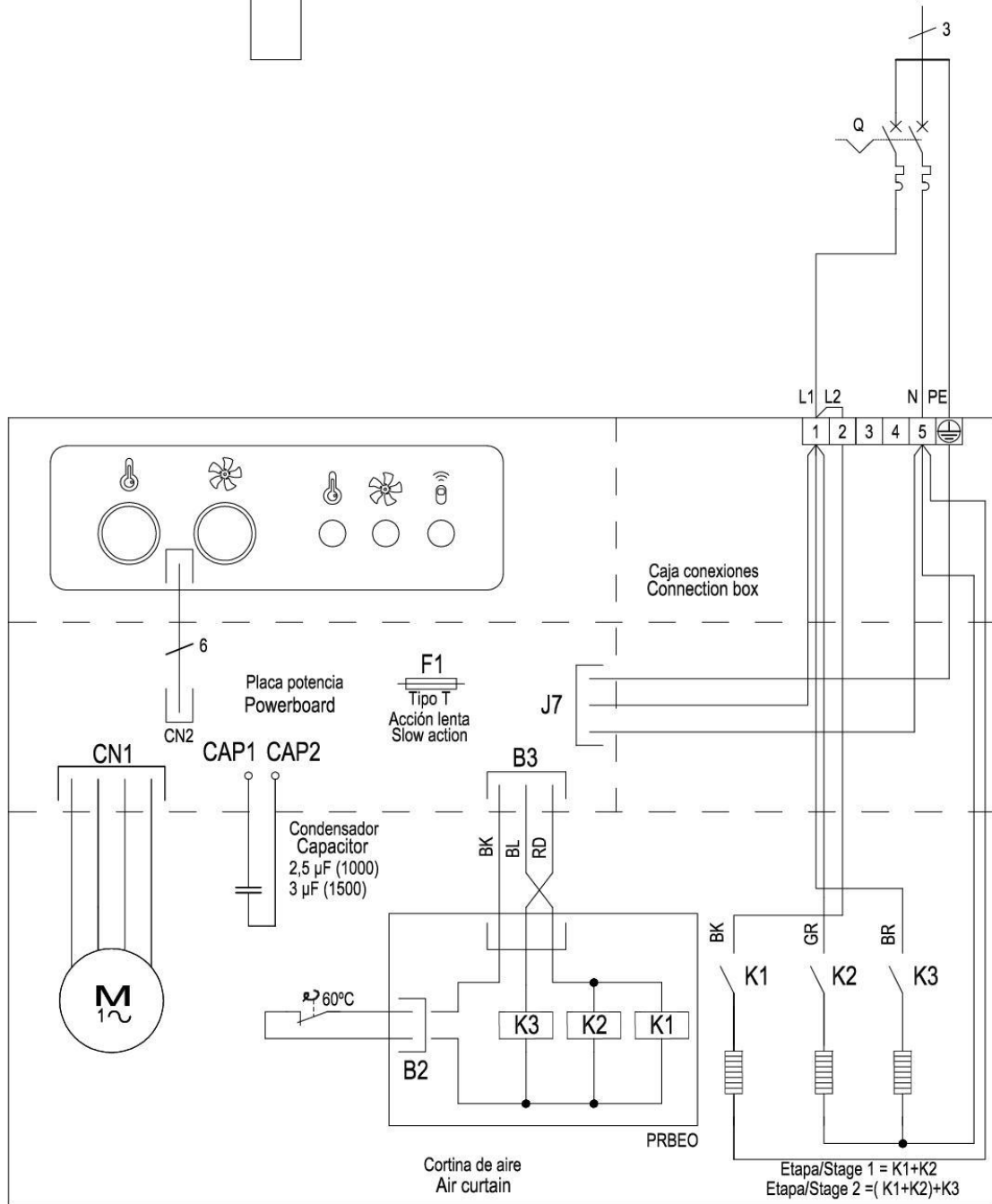

BK	Negro/ Black	RD	Rojo/ Red	BR	Marrón/ Brown
BL	Azul/ Blue	GR	Gris/ Grey		

ESQUEMA ELÉCTRICO CORTINA DE AIRE
WIRING DIAGRAM OF AIR CURTAIN

CONTROLADOR 2 VELOCIDADES, CORTINA SOLO AIRE 230V~1 1000-6kW /1500-6kW
ELECTRICAL, 2 SPEEDS 230V~1 1000-6kW /1500-6kW

Pág./ Page 1 de/ of 1
Doc. AIRDOE07920
R13 - 15/12/16

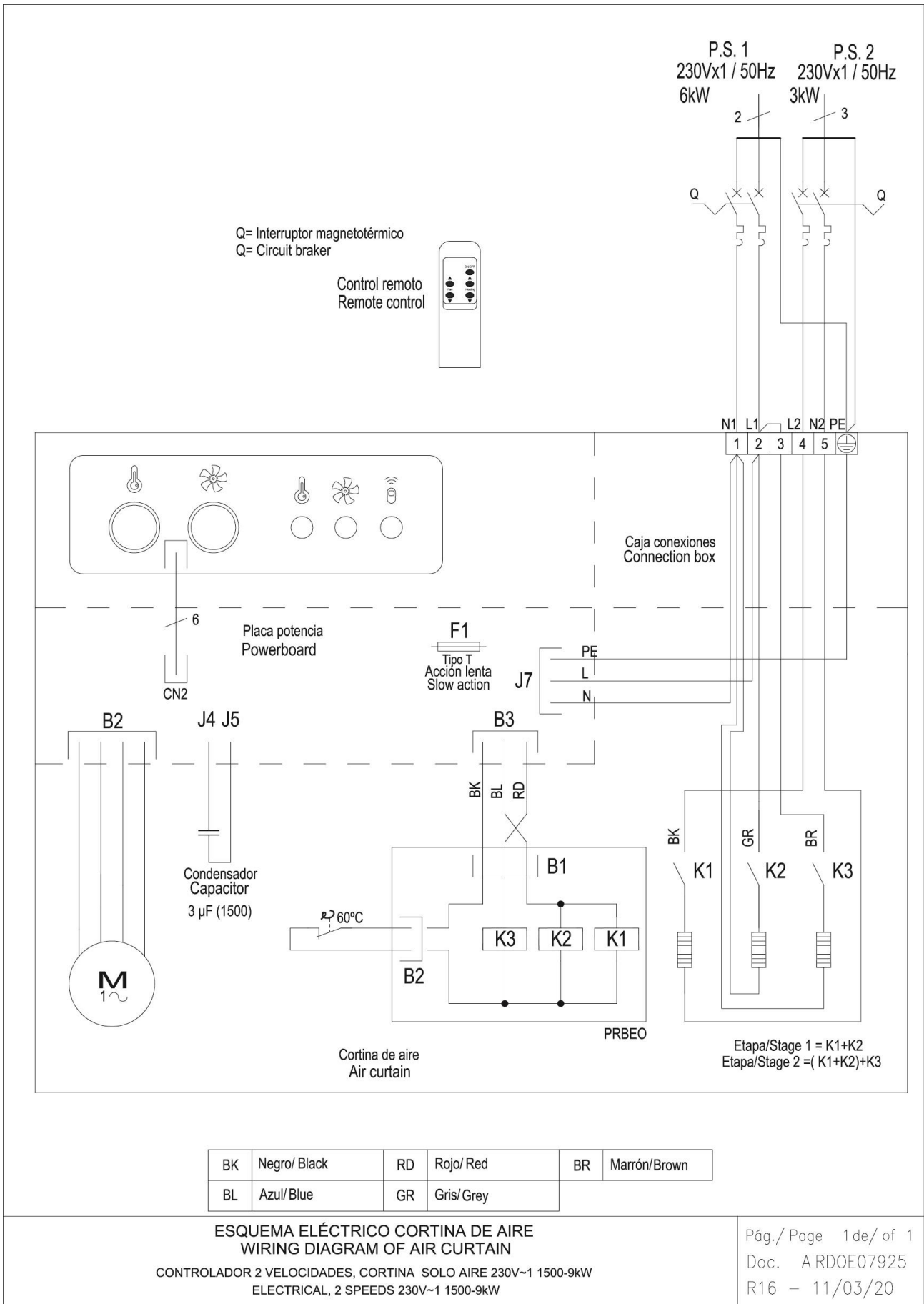

Control remoto
Remote control

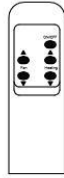

Q= Interruptor magnetotérmico
Q= Circuit breaker

230Vx1 / 50Hz

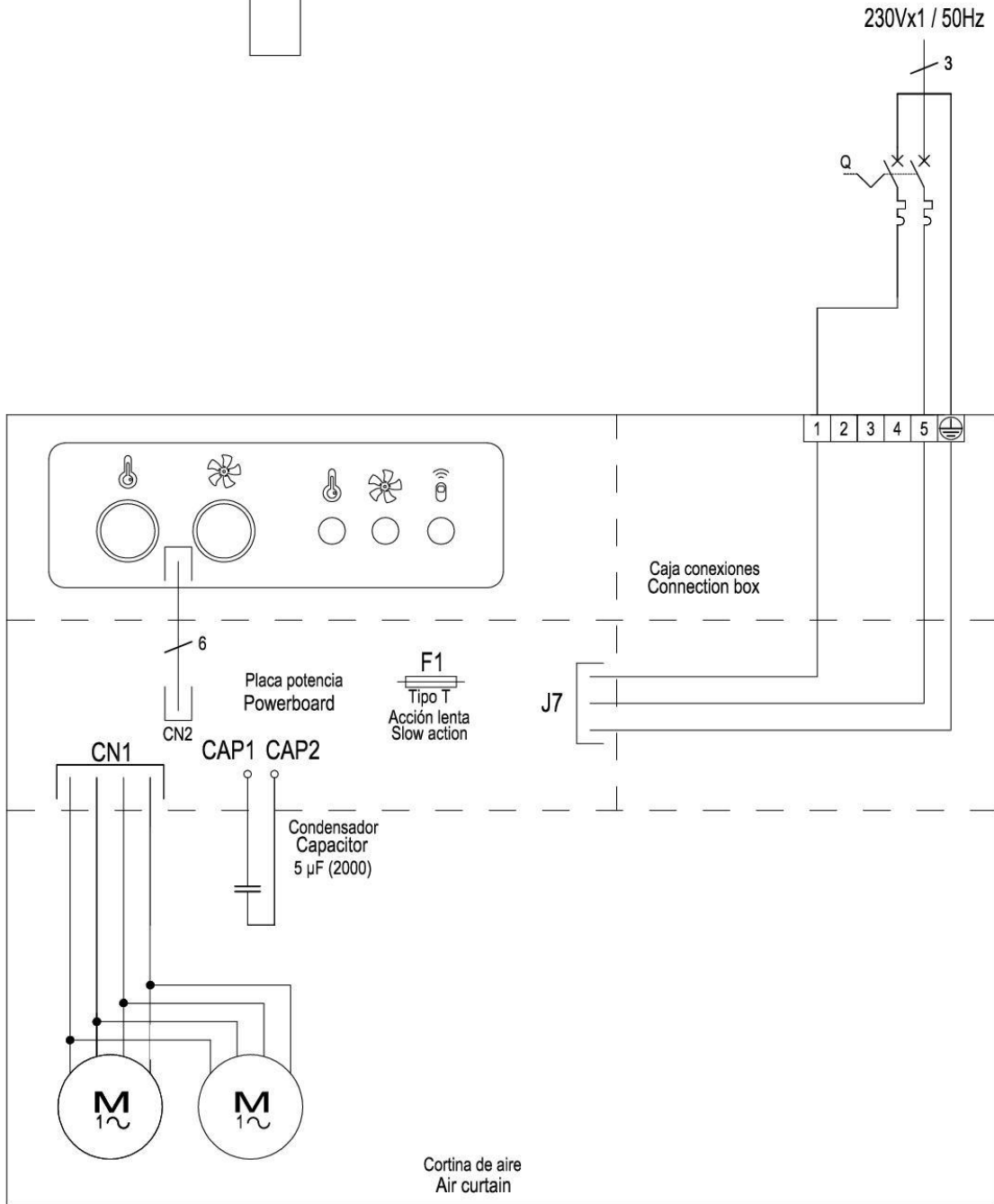

ESQUEMA ELÉCTRICO CORTINA DE AIRE
WIRING DIAGRAM OF AIR CURTAIN
CONTROLADOR 2 VELOCIDADES, CORTINA SOLO AIRE OPTIMA WIRELESS 2000
AIR ONLY, 2 SPEEDS OPTIMA WIRELESS 2000

Pág./ Page 1 de/ of 1
Doc. AIRDOE07950
R12 - 08/02/16

Q= Interruptor magnetotérmico
Q= Circuit breaker

Control remoto
Remote control

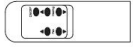

400Vx3 / 50Hz

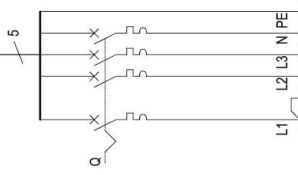

Caja conexiones
Connection box

Placa potencia
Powerboard

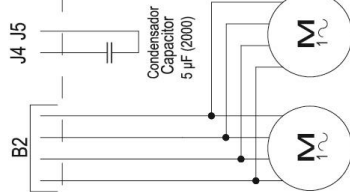
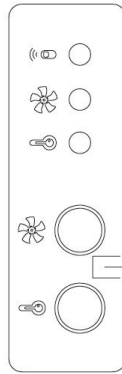

Corfina de aire
Air curtain

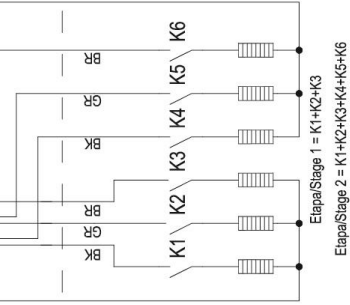
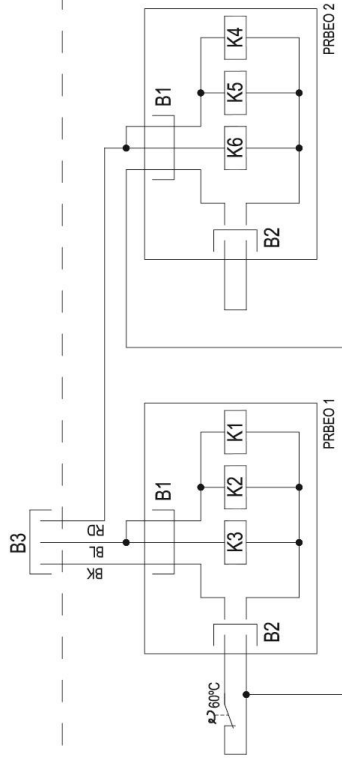

Negro/Black	RD	Rojo/Red	BR	Marrón/Brown
Azul/Blue	GR	Gris/Grey		

ESQUEMA ELÉCTRICO CORTINA DE AIRE
WIRING DIAGRAM OF AIR CURTAIN

CONTROLADOR 2 VELOCIDADES: CORTINA ELÉCTRICA OPTIMA WIRELESS 2000-400V-3 11.3kW
ELECTRICAL. 2 SPEEDS 400V-3 OPTIMA WIRELESS 2000-11.3kW

Pág./ Page 1 de/ of 1
Doc. AIRDOE07960
R14 - 11/03/20

Q= Interruptor magnetotérmico
Q= Circuit breaker

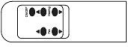

Control remoto
Remote control

P.S.1
230Vx1/50Hz

P.S.2
230Vx1/50Hz

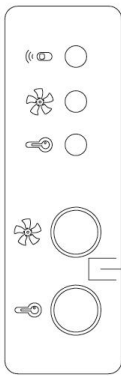
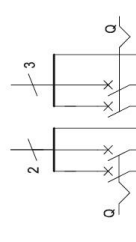

Placa potencia
Powerboard

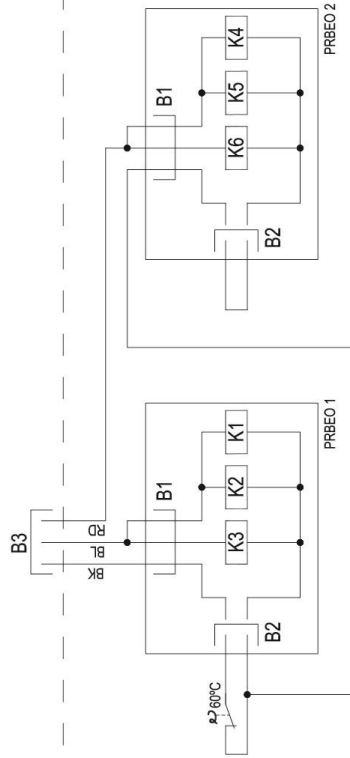
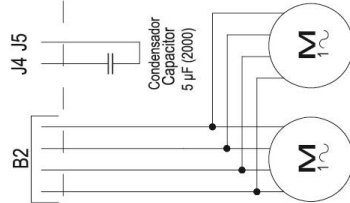

Caja conexiones
Connection box

Caja conexiones
Connection box



Cortina de aire
Air curtain

Etapas/Stage 1 = K1+K2+K3
Etapas/Stage 2 = K1+K2+K3+K4+K5+K6

Negro/Black	RD	Rojo/Red	BR	Marrón/Brown
Azul/Blue	GR	Gris/Grey		

ESQUEMA ELÉCTRICO CORTINA DE AIRE
WIRING DIAGRAM OF AIR CURTAIN

CONTROLADOR 2 VELOCIDADES: CORTINA ELÉCTRICA OPTIMA WIRELESS 2000 230V-11.3kW
ELECTRICAL: 2 SPEEDS OPTIMA WIRELESS 230V-11.3kW

Pág./ Page 1 de/ of 1
Doc. AIRD0E07965
R17 - 11/03/20

OPTIMA WIRELESS | Air Curtains For Commercial Doors



Characteristics



- Self-supporting casing construction made of galvanized steel plate, finished in structural epoxy-polyester painting white colour RAL9016 as standard. Other colours are available on request.
- Micro-perforated inlet grille with filter functions and easy service. It does not need prefilter.
- Anodized aluminium outlet vanes, airfoil shaped.
- Low noise twisted cross-flow fans driven by a 2-speed external rotor motor.
- "E" type with electrical shielded elements, two stages with integrated regulation.
- "A" type without heating, air only.
- Included regulation with infrared remote control and inbuilt keypad with leds.

Specifications

AIR ONLY					
Model	Airflow m ³ /h	Power Fans 230V-50Hz W	Current Fans 230V-50Hz A	Noise Level (5 m) dB(A)	Weight kg
OPT W 1000 A	1500	80	0,41	35/50	17,5
OPT W 1500 A	2150	117	0,53	36/51	25,5
OPT W 2000 A	2900	160	0,82	38/53	33

ELECTRICAL HEATED								
Model	Airflow m ³ /h	Electrical Heating Capacity kW	Power Supply	Maximum Electrical Heating Current A	Power Fans 230V-50Hz W	Current Fans 230V-50Hz A	Noise Level (5 m) dB(A)	Weight kg
OPT W 1000 E	1500	4/6	400Vx3	8,7	80	0,41	35/50	20,5
OPT W 1000 E230	1500	3,8/5,6	230Vx1	24,5	80	0,41	35/50	20,5
OPT W 1500 E	2150	6/9	400Vx3	13,0	117	0,53	36/51	27,5
OPT W 1500 E230-6	2150	3,8/5,6	230Vx1	24,5	117	0,53	36/51	27,5
OPT W 1500 E230-9	2150	6/9	230Vx1 (*)	39,1	117	0,53	36/51	27,5
OPT W 2000 E	2900	5,6/11,3	400Vx3	16,3	160	0,82	38/53	42
OPT W 2000 E230	2900	5,6/11,3	230Vx1 (*)	49,1	160	0,82	38/53	42



(*) 2 separated power supplies.

Dimensions

	L	A	B
OPT W 1000	1050	940	-
OPT W 1500	1550	1440	-
OPT W 2000	2050	1940	970

(*) Manual regulation using inbuilt keypad or by infrared remote control

MAINTENANCE INSTRUCTIONS

	<i>For safety, before any cleaning, disconnect power supply using the controller.</i>
	<i>It is forbidden to open the service door (risk of electrical discharge and being trapped in fans). Service and maintenance should be done only by introduced and qualified workers.</i>
	<i>Do not use water or steam for cleaning the internal parts and components of the air curtain.</i>

External cleaning

Air curtains don't need any kind of maintenance except from the cleaning of the casing and the inlet grille. It is recommended to weekly clean the inlet grille. It's important to make sure that the air curtain is OFF, otherwise the dust mixed with a wet cloth would create a kind of paste that will damage the fan rotor when it sucks the air.

Annual cleaning of the discharge area (outlet).

The casing of the air curtain should be cleaned with a wet cloth and non-aggressive detergent. Do not use caustic soap or acids.

The inlet grille prevents the settling of dust and strange objects in the internal elements. It is recommended to check periodically that the inlet grille is free of any object that could interfere the air entrance (plastic bags, papers, etc.).



In case of a micro drilled inlet grille (it has filter functions to prevent the entrance of dust to the internal elements) use a vacuum cleaner with a soft brush in order to avoid any damages in the micro drilled grille. We recommend cleaning the grille every week (depending on the amount of the incoming air dust).

Internal cleaning

In models with micro drilled grille is recommended to clean the inside of the unit with a vacuum at least once every two years (*), best before the winter season, with qualified staff.

(*) These periods are indicative, depending on the ambient conditions of every installation.

In places with a high number of particles in suspension is desirable to increase the frequency of the internal cleaning (including the city centers, near construction sites, etc.).

REPAIRS AND REPLACEMENTS



Installation and electrical connections must be done by qualified workers and following these instructions.



Before any repairs are undertaken, please:



- **Inform people that there is work in progress.**
- **Disconnect the power supply and protect the thermal magnet (so nobody can restart it accidentally).**
- **Make sure there is no tension in the air curtain.**
- **Make sure the fans are stopped.**
- **Use only original spare parts.**

To **open the service door**, follow these steps:

- Remove the lateral
- Lever softly between the grille and the door.



Motor or turbine replacement

Before the motor replacement, advise people that there is work in progress.

Release the connector of the motor. Release the fixation screw of the impeller (Allen L hex key 2.5mm) through the discharge opening.

Remove motor by loosening the fixation screws. Install the replacement motor following the process in reverse order, making sure that the motor and the turbine fit perfectly, the turbine screw must fit in with the flat part of the motor axle.



Fuse replacement

Before the replacement, inform people that there is work in progress, disconnect main supply, make sure that the unit is without tension and that the fans are stopped.

Open the service door and unplug the visible cable from the plate and the condenser. The fuse is protected by a plastic box. Pull up the plastic box with the help of a screwdriver and replace the fuse.

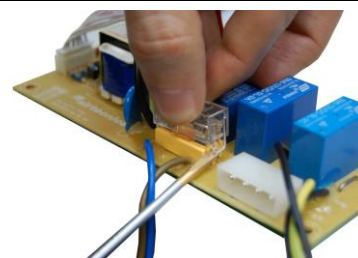

Plate replacement

Open the service door and unplug the visible cables from the plate and the condenser.



Heater replacement

Before the replacement, inform people that there is work in progress, disconnect main supply, make sure that the unit is without tension and that the fans are stopped. Before proceeding to unfasten the heater fixing screws, we must:

Electrical Heaters: Disconnect the power supply from the electrical element.

Heat exchanger replacement

Before change of heater, inform people that there is work in progress, stop the air curtain through the inbuilt controller and disconnect main supply. Make sure that the unit is without tension and the fans are stationary. Before removing the screws that fix the heater, we have to:



1. Disconnect the power supply of the battery: remove the screw-earth of the connection box and disassemble from the equipment.



2. Disconnect the cables 2, 3 and 4 of the connections box.

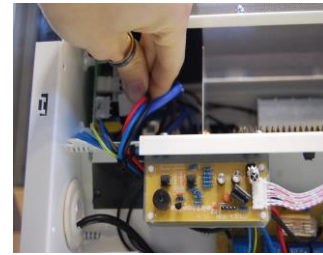

3. Disconnect the connector B1.

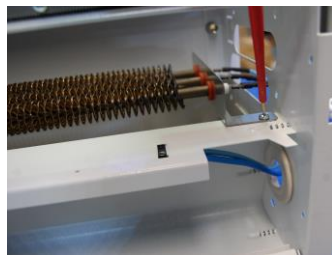

4. When we have the heater ready, we proceed to remove the fixation screws of the battery to remove it. To assemble the new heater follow the same process in reverse order.

Once removed the screws we will proceed to remove the water coil or electrical element using gloves to avoid any cut.

ACCESSORIES

Supports, vibration dampers, etc. depending on the model.



DECLARATION OF CONFORMITY



Declaration  of conformity / Declaración  de conformidad

Manufacturer **Motors i Ventiladors S.L. (AIRTÈCNICS)**
Fabricante **Conca de Barberà 6, Pol. Ind. Pla de la Bruguera**
08211 Castellar del Vallès (Barcelona) Spain

We declare, under our sole responsibility, that the product(s)
Declaramos, bajo nuestra única responsabilidad, que el/los producto(s)

Air Curtains
Cortinas de aire

with models
con los modelos

Minibel, Optima, Recessed Optima, Windbox, Recessed Windbox, Smart, Dam, Deco, Kool, Variwind, Rotowind, Invisair, Rund, Zen, Duojet, Triojet, Max, Recessed Dam, Recessed Compact, Maxwell

is/are developed, designed and manufactured in accordance with the following directive(s)
ha(n) sido desarrollado(s), diseñado(s) y fabricado(s) de acuerdo con la(s) siguiente(s) directiva(s)

Low Voltage Directive 2014/35/UE
Directiva Baja Tensión 2014/35/UE

Electromagnetic Compatibility Directive 2014/30/UE
Directiva Compatibilidad Electromagnética 2014/30/UE

Restriction Certain Hazardous Substances Directive 2011/65/EU (RoHS)
Directiva Restricción Substancias Peligrosas 2011/65/EU

Eco-design Energy-related Products Directive 2009/125/EC
Directiva Diseño Ecológico Productos Con Energía 2009/125/CE

applying the following harmonized standards in particular
aplicando las siguientes normas armonizadas en particular

LVD: EN 60335-1:2012 + AC:2014 + A11:2014
EN 60335-2-30:2010 + A11:2012

EMC: EN 61000-6-2:2006
EN 61000-6-3:2007 + A1:2012
EN 55014-1:2008 + A1:2009 + A2:2012
EN 55014-2:2015

RoHS: EN 50581:2012

Date / Fecha
Name / Nombre
Position / Cargo

03/05/2016
Jordi Oltra Orta
General Manager / Director General





Model <i>Modelo</i>	WINDBOX M 2000 E			
Airflow <i>Caudal</i>	3600	m3/h		
Blowers <i>Ventiladores</i>	1,88	A	0,424	kW 230 V/50Hz
Heating capacity <i>Calefacción</i>	80/60 °C		60/40 °C	
Water Coil <i>Agua</i>		kW		kW
Electric Coil <i>Batería Eléctrica</i>	6/12/18	kW	400V~3 50Hz	
Serial Number <i>Número de Serie</i>	2015-07-06 / 61.990			

Air curtain identification

Each air curtain is identified by a unique serial number printed in a label located inside the door service. There is also indicated the model and their technical characteristics (flow, fans technical characteristics and power heating).

It is indispensable to have this number to facilitate possible replacements or technical information of the air curtain in question.

If you detect some error in this manual, we'll be pleased to receive your *feedback*, it helps us to improve even more.

Airtècnics reserves the right to modify some of the specifications in this manual.

GUARANTEE

Your air curtain is guaranteed for a period of one year from the date of purchase. We will adjust, repair or replace at our discretion from our warehouse any defect, system failure or part found to be defective. The assembly cost out of our warehouse is at buyer expense. The products that, in our eyes, have been inadequately used, incorrectly manipulated, improperly installed, connected to different nominal tensions, modified, repaired by non-authorized workers or that have suffered damages during transport are totally excluded from the guarantee.

To validate the guarantee it should be correctly filled and enclosed with the invoice that vouches for the buying date. If it is manipulated, it will lose all validity.

It is the buyer's responsibility to take the necessary safety measures because in case of a failure or mistake in one of our products, no damages to third parties, sets or installations will occur.

✂ -----

Guarantee draft

Air curtains data:

Model: Series number:
 Invoice date: Invoice number:

Buyer data:

Name:
 Address:
 Country: Phone: Fax:

Seller data:

Name:
 Address:
 Country: Phone: Fax:

Buyer signature and stamp

Seller signature and stamp