



INSTALLATION, OPERATION AND MAINTENANCE MANUAL



Air Curtains ZEN BB

Please, read these instructions carefully before attempting installation

SECURITY ADVISE SYMBOLS



Attention, Danger, Safety Advice!



Danger from electric current or high voltage!



Injuries risk!



Danger! Do not stay underneath: Heavy load.



Important information.

AIRDOM05541-R1 (16/09/2020)

INDEX

CONNECTION DIAGRAM	3
INSTALLATION.....	4
Power Supply	4
PCBoard and Control (Only electrical heated)	4
Fixing.....	5
Water coils.....	5
Electrical elements.....	5
STORAGE AND TRANSPORT	6
WORKING INSTRUCTIONS	6
Control PCBoard characteristics	6
Standard controller	6
WIRING DIAGRAMS.....	6
DATASHEET	12
MAINTENANCE INSTRUCTIONS.....	14
External cleaning	14
Internal cleaning	14
REPAIRS AND REPLACEMENTS	15
Fan replacement.....	15
Fuse and PCB replacement.....	16
Heater replacement	16
FAILURES AND SOLUTIONS.....	18
ACCESSORIES	19
DECLARATION OF CONFORMITY	20
Air curtain identification.....	21
GUARANTEE	21

CONNECTION DIAGRAM

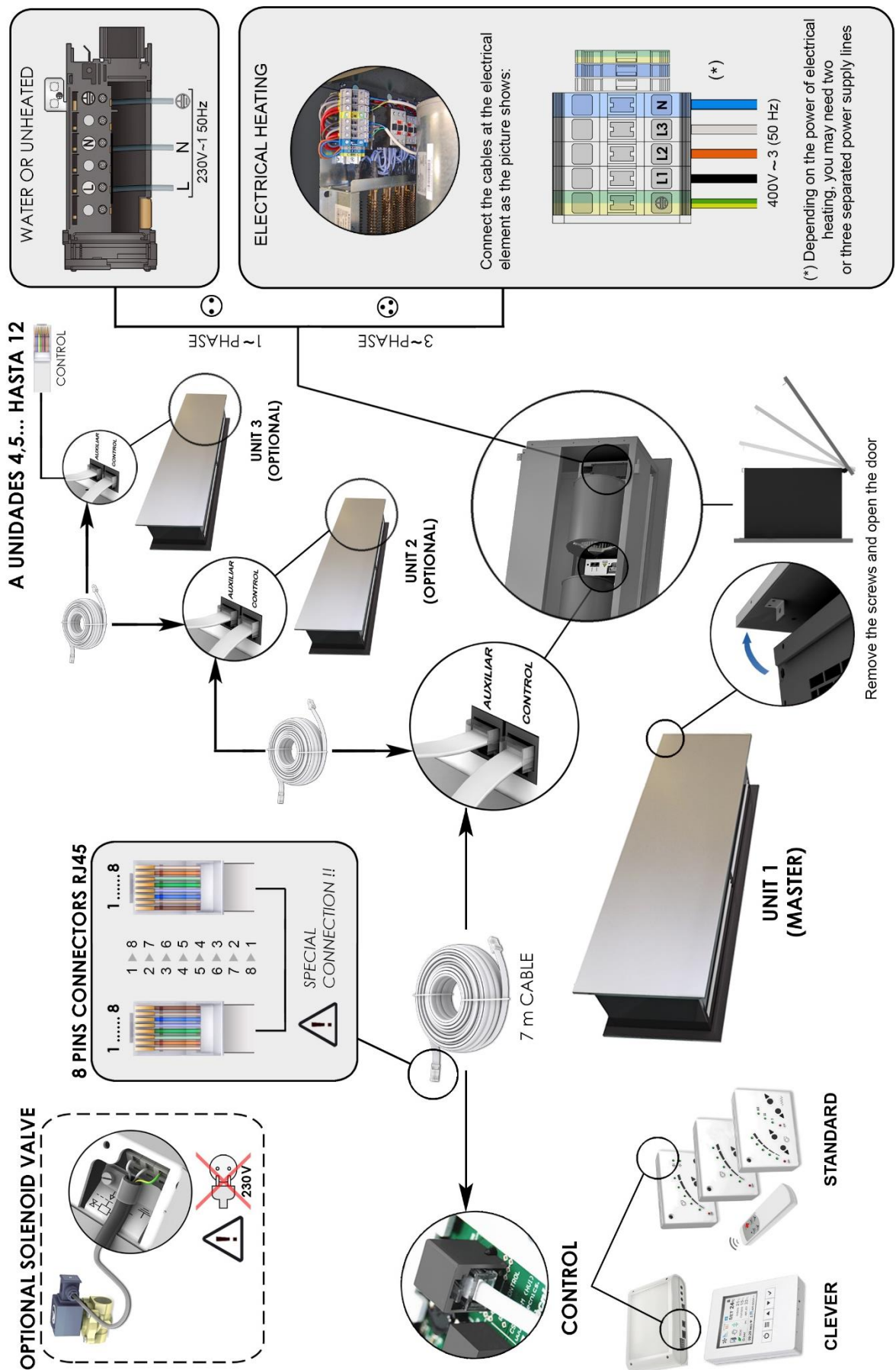

A UNIDADES 4,5... HASTA 12

INSTALLATION

Valid for models: **Zen BB**

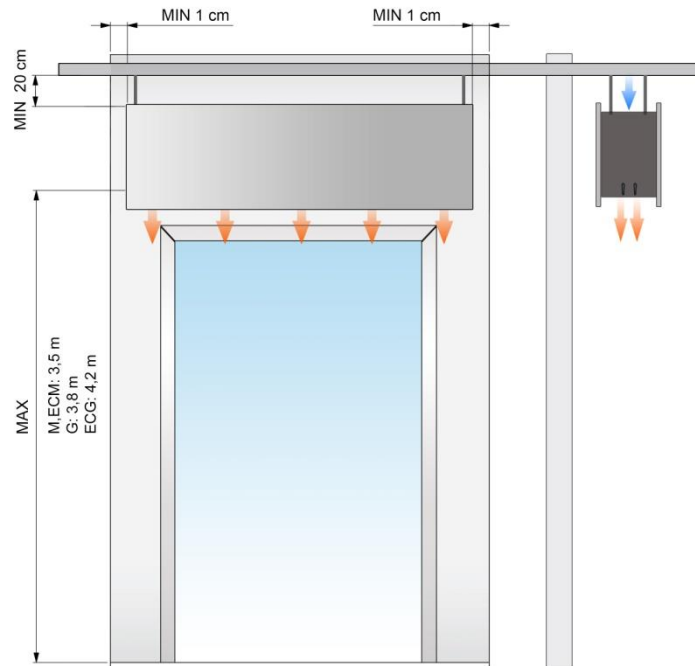

MAX. Maximum recommended height, MIN. Minimum recommended distance

(***) Customizable panels

Minimum recommended distance between the inlet grille and any obstacle is of 200mm.

	<i>Installation work, connection, disconnection, electrical wiring, mechanical maintenance and service must be done by qualified people observing these instructions and in accordance with all applicable norms and standards. If the unit is operated with additional controller, please consider its specific instructions.</i>
	<i>It is necessary to open the air curtain to connect it because connections (power supply, control, water pipes when existing) are placed inside. Fixations are external. See how to open service door at repairs section.</i>
	<i>For safety, the air curtains never have to be stopped by disconnecting them from the main supply, always through the controller and waiting 10 minutes at least to disconnect the main supply. In case to not follow these instructions, the internal parts of the air curtain can be damaged.</i>

Power Supply

To connect the power supply there is a black connection box inside the air curtain (located on bottom).

For an ambient air or water heated air curtain, just connect the single phase 230Vx1.

In case of an air curtain with electrical heating we will also connect the three phase 400Vx3 of the electrical element.

PCBoard and Control (Only electrical heated)

To connect the controller there is a PC Board (printed circuit) located inside the air curtain (located on bottom). There is need to open the unit to connect it.

Use the 10 meters RJ45 cable supplied with the equipment. The communication between the controller and the PCB is digital and low-voltage.

Optionally, there are different accessories and controllers available, to meet every customer needs (Thermostats, hand-auto, door contacts, anti-freezing sensor, supports, valves, etc.).

The new total control for ventilation technology is advanced *Clever* regulation. Leading the new generation of air curtains management with maximum control providing maximum energy saving. *Clever* automatically

adapts the functioning of the air curtain to the entrance climatic conditions in order to keep the comfort and energy saving.

For more information consult the *Clever Control* manual.

Fixing

Units are provided of several external suspension points, depending on the weight and length of each model (see exact situation of the points at the air curtains characteristics page).

Generally, air curtains work horizontally but also can be installed vertically using feet supports (*Accessories* section).

The fixing of the air curtain should be managed according to the weights of each unit shown on the technical data page. The installation can be made through threaded rods, cable tensors or other supports. See available supports in the accessories section.

Water coils

Clever Control has different outputs to manage an electro valve (open/close water entrance) or proportional valve (0-100% water entrance) or any other devices.

It is recommended:

- Close the hot water circulation (by turning the electrovalve OFF) to avoid fan overheating while the unit is OFF. Electrovalve is optional.
- Install 2 cutoff water valves (supply and return) in order to disassemble the equipment easily.
- Install a bleeding valve at the highest part of the water heating circuit.

The ambient temperature should be always over +4°C, otherwise it will be necessary to provide an anti-frost protection device.

Water coils have a drainage point placed at the end part of the intake manifolds area.

Some special units are provided with condensation tray prepared to work with cold water. In this case, these units can't work at high ventilation speed (depending on model, length and power it will be a speed limitation). Intake air speed should not be higher than 3m/s because water drops can appear on the outlet.

Electrical elements

The heater element has resistances bars (the number depends on length) that combined give 3 stages of heating. The control is made by contactors.

All electrical elements are protected electrically and electronically against overheating (see "*Operating instructions*" section).

The electrical controllers have the option to install an external thermostat that turns on/off the heating in order to control the temperature.

During the first uses scent can be emitted but it disappears in a few days.

STORAGE AND TRANSPORT



Attention! Heavy load.
Do not step underneath hanging load during the transport or assembly.

Store in a dry place and weather protected in its original packaging. In case the packing is opened, cover the air curtain to protect it from dust. Do not step or put heavy load over the package to avoid damages to the material. Store temperatures are between -20°C and +40°C.

When carrying material, make sure it is not damaged by the forklift (fork penetration in the packaging). Please see the *Packaging* indications.

WORKING INSTRUCTIONS



For safety, the air curtains never have to be stopped by disconnecting them from the main supply, always through the controller and wait for 10 minutes at least to disconnect the main supply. In case to not follow these instructions, the internal parts of the air curtain can be damaged.

Control PCBoard characteristics

Fan speed is regulated through the input voltage variation of the fans set. The transformer has 5 output voltages: 120, 140, 170, 200 and 230 Volts.

Standard controller

See enclosed *Clever Control* manual.

WIRING DIAGRAMS

For the models ZEN BB, the following wiring diagrams are enclosed:

- Warm water heated or only air 1000-2500 with Clever Control. Diagram: AIRDOE09030
- Warm water heated or only air 3000 with Clever Control. Diagram: AIRDOE09032
- Electrical air curtain 1000-1500 with Clever Control. Diagram: AIRDOE09033
- Electrical air curtain 2000-2500 with Clever Control. Diagram: AIRDOE09036
- Electrical air curtain 3000 with Clever Control. Diagram: AIRDOE09040

In case you need to connect the equipment to a PLC, the corresponding wiring diagrams will be supplied.

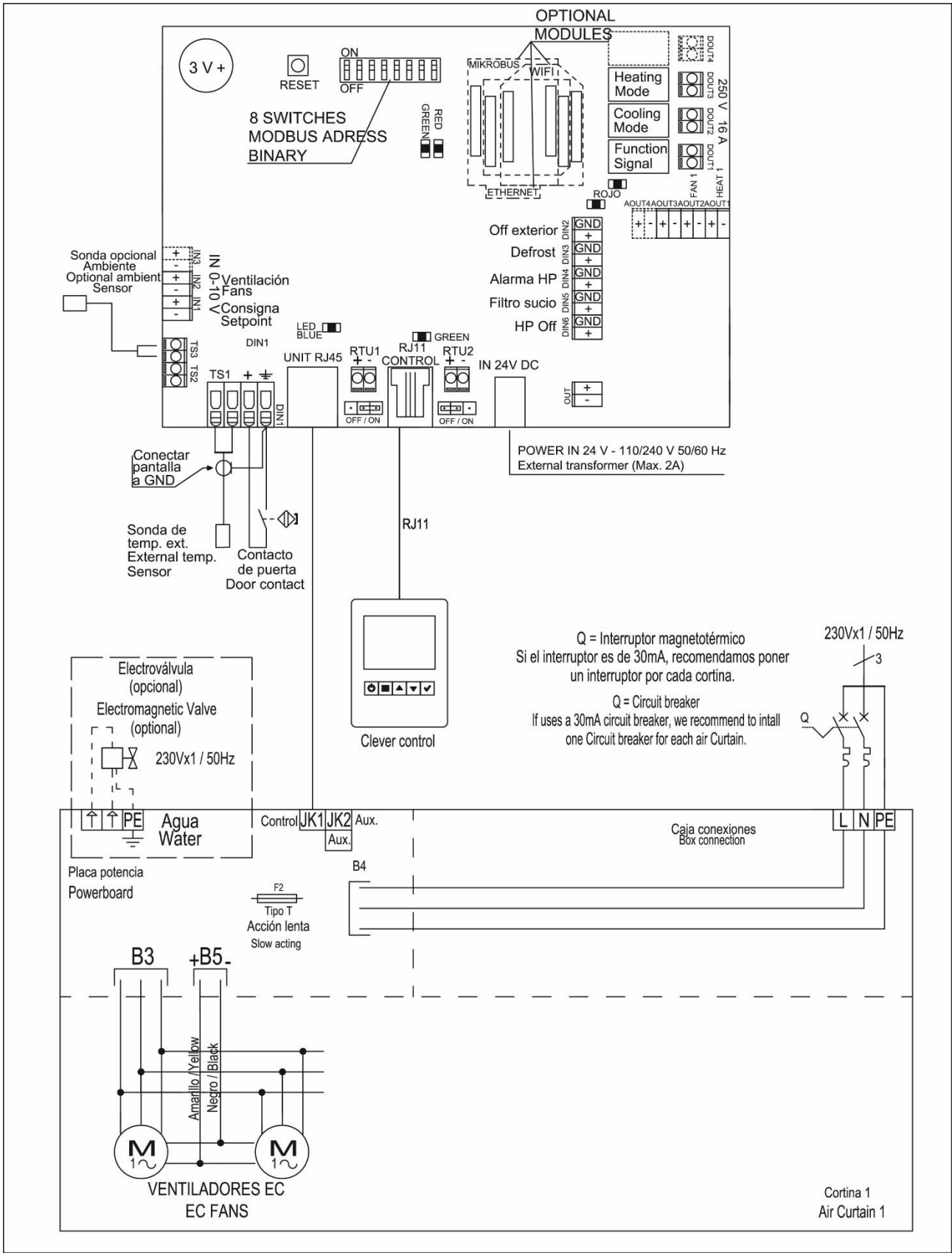

ESQUEMAS ELÉCTRICOS CORTINA DE AIRE VENTILADORES EC
WIRING DIAGRAMS OF AIR CURTAIN EC FANS

CONTROLADOR CLEVER AGUA O AIRE CORTINA BB1000, 1500, 2000
CLEVER CONTROLLER ONLY AIR & WATER. AIR CURTAIN BB 1000, 1500, 2000

Pág./ Page 1 de/
Doc. AIRDOE09030
R3 - 15/09/20

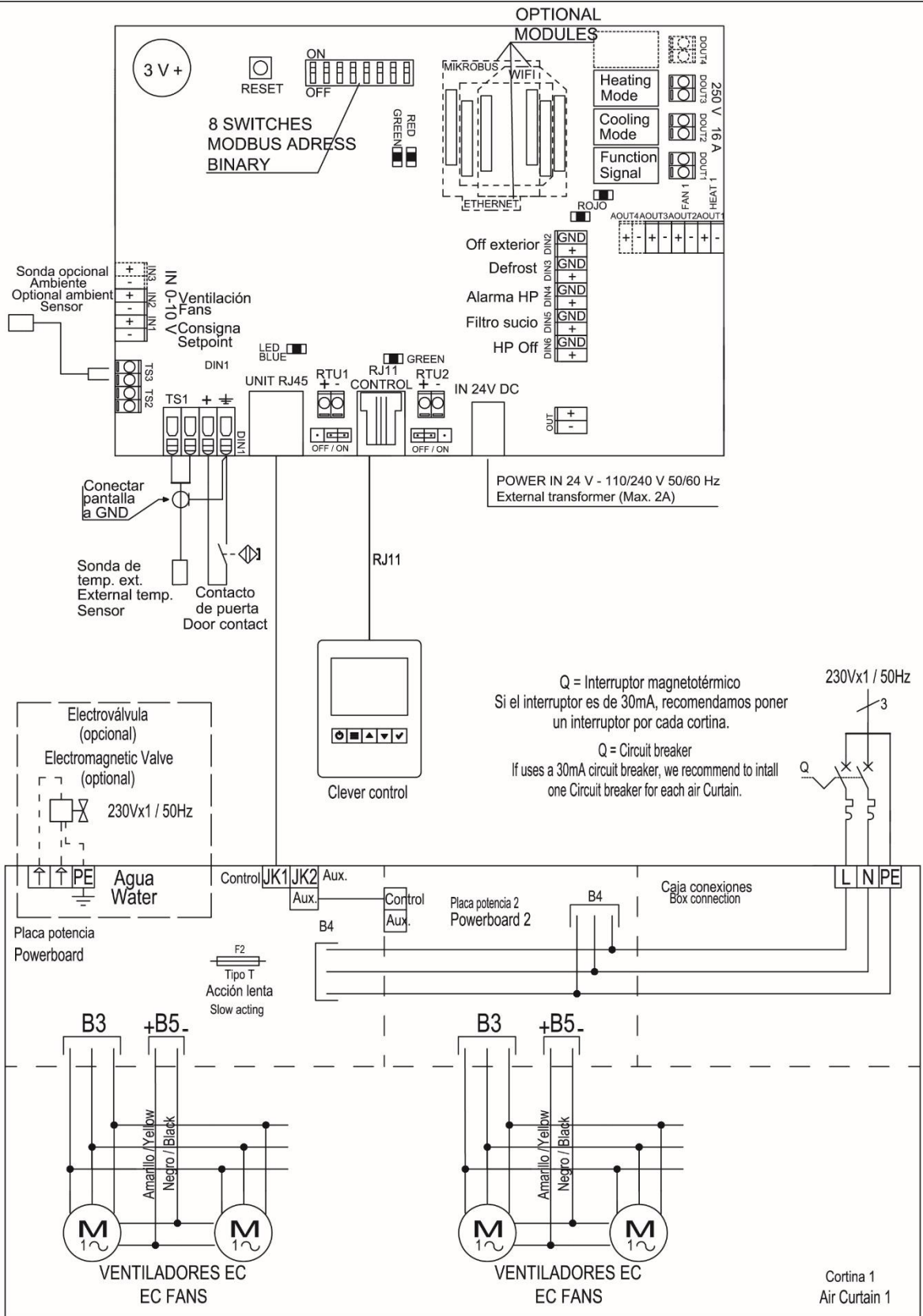

ESQUEMAS ELÉCTRICOS CORTINA DE AIRE VENTILADORES EC
 WIRING DIAGRAMS OF AIR CURTAIN EC FANS
 CONTROLADOR CLEVER AGUA O AIRE CORTINA BB 2500, 3000
 CLEVER CONTROLLER ONLY AIR & WATER. AIR CURTAIN BB 2500, 3000

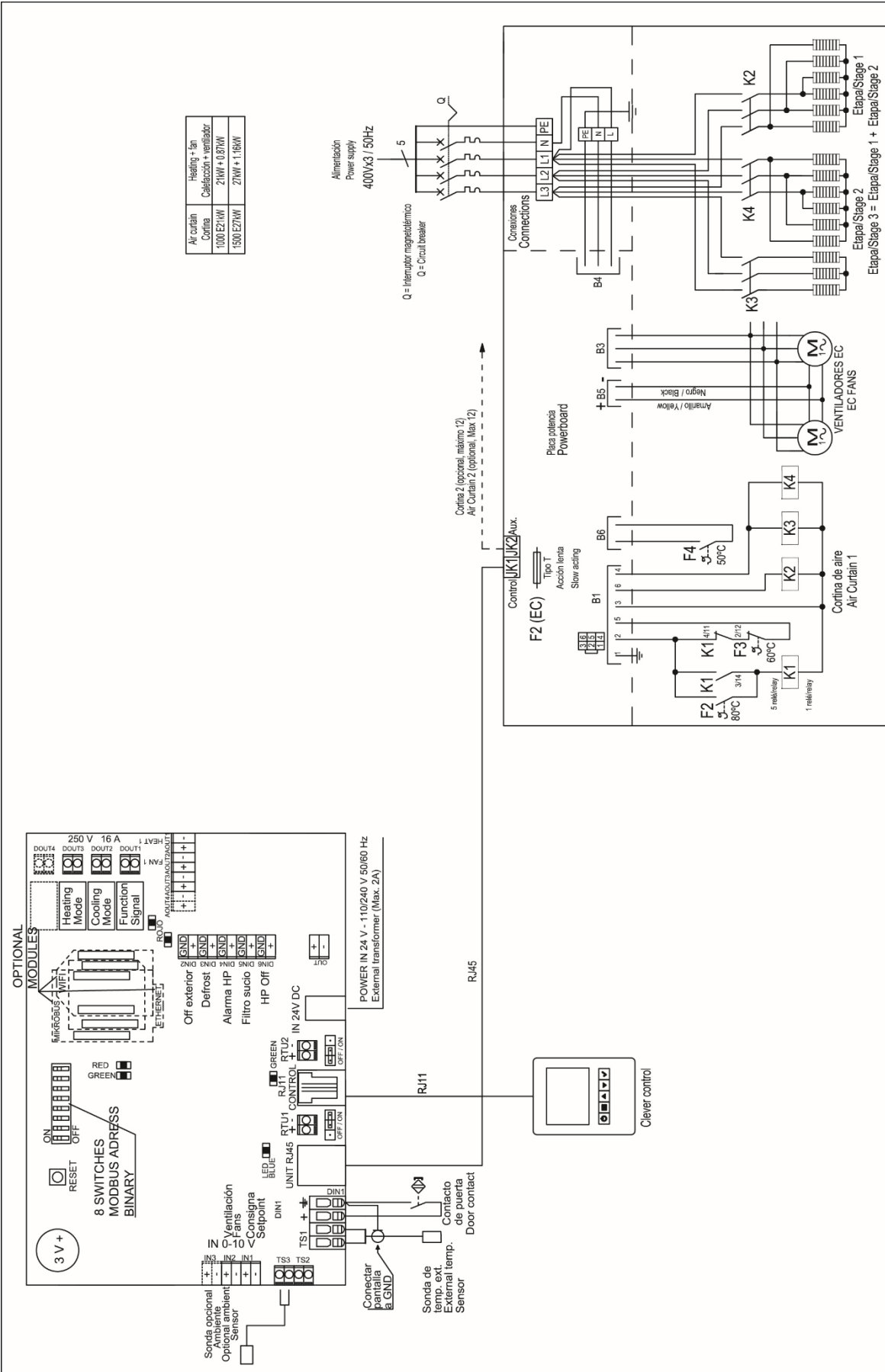

ESQUEMAS ELÉCTRICOS CORTINA DE AIRE BB VENTILADOR EC
WIRING DIAGRAMS OF AIR CURTAIN BB EC FANS

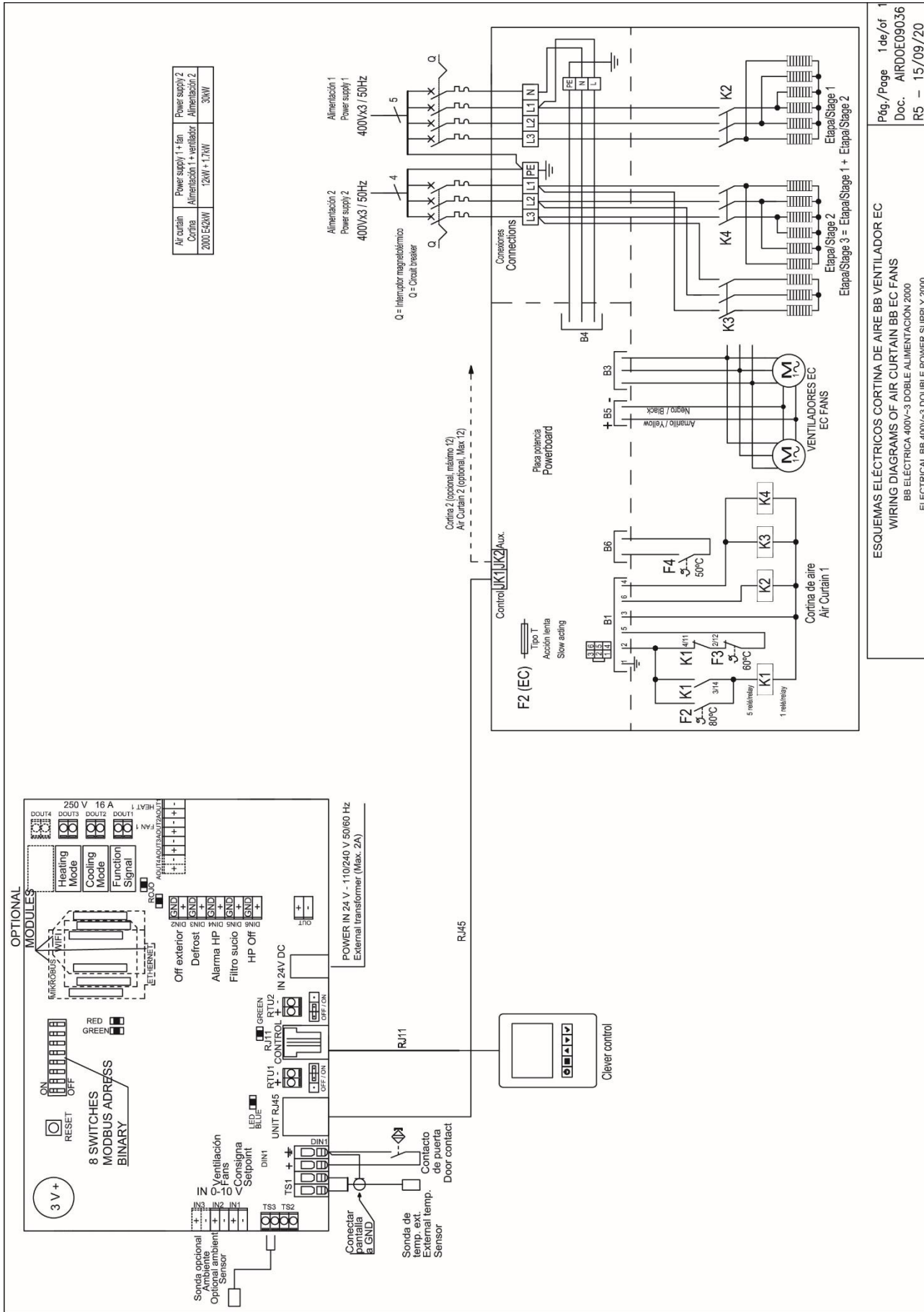

ESQUEMAS ELÉCTRICOS CORTINA DE AIRE BB VENTILADOR EC
 WIRING DIAGRAMS OF AIR CURTAIN BB EC FANS
 BB ELÉCTRICA 400V-3 DOBLE ALIMENTACIÓN 2000
 ELECTRICAL BB 400V-3 DOUBLE POWER SUPPLY 2000

Air curtain	Power supply 1 + fan	Power supply 2
Cortina	Alimentación 1 + ventilador	Alimentación 2
2500 E-6kW	16kW + 2kW	30kW
3000 E50kW	20kW + 2.3kW	30kW

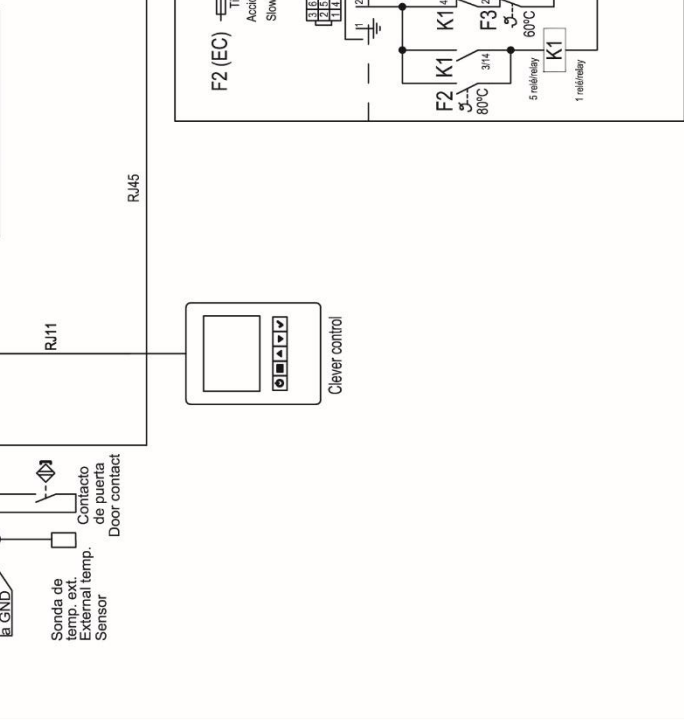
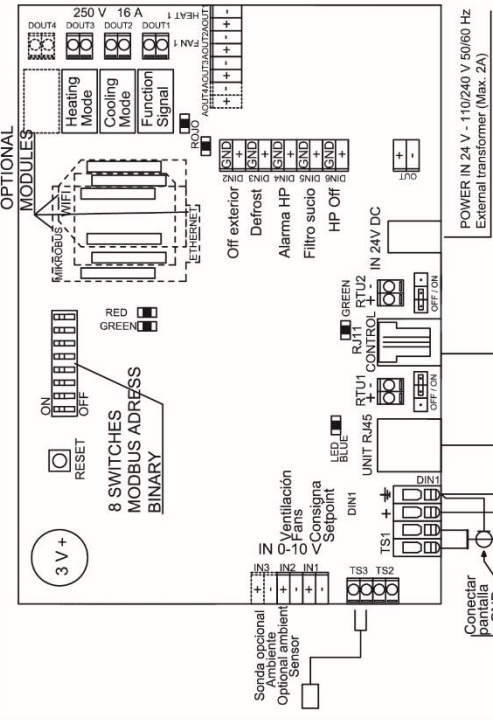

Alimentación 1 Power supply 1 400Vx3 / 50Hz	Alimentación 2 Power supply 2 400Vx3 / 50Hz
---	---

Q = Interruptor magnetotérmico
Q = Circuit breaker

Etapa/Stage 1 + Etapa/Stage 2
Etapa/Stage 3 = Etapa/Stage 1 + Etapa/Stage 2

ESQUEMAS ELÉCTRICOS CORTINA DE AIRE BB VENTILADOR EC
WIRING DIAGRAMS OF AIR CURTAIN BB EC FANS
BB ELÉCTRICA 400V-3 DOBLE ALIMENTACIÓN 2500 y 3000
ELECTRICAL BB 400V-3 DOUBLE POWER SUPPLY 2500 & 3000

ZEN BB | Decorative Air Curtains For Commercial And Industrial Doors



Characteristics



- Decorative air curtain in contemporary architectural style. Its minimalist and smart design integrates in any environment and offers infinite options to customize.
- Can include personalized logotypes, signs or graphic designs. It can even incorporate clocks or lighting.
- Front anodized aluminium panels. Optionally manufactured in brushed or mirror polished stainless steel. Other materials are possible, such as wood, metal, etc.
- Central structure made of galvanized steel finished in black forge as standard. Other colours are available on request.
- Anodized aluminium outlet vanes, airfoil shaped, adjustable in both directions.
- EC Double-inlet centrifugal fans driven by an external rotor motor and low noise level, with very low consumption efficiency fans.
- "P" type with water heated coil. "E" type with electrical shielded elements, three stages with integrated regulation. "A" type without heating, air only. Optional expansion DX coil.
- Includes Advanced Clever control (programmable, automatic, intelligent, energy saving, Modbus RTU for BMS...) with Plug&Play control and 7m RJ11 cable.

Specifications

AIR ONLY					
Model	Airflow m³/h	Power Fans 230V-50Hz kW	Current Fans 230V-50Hz A	Noise Level (5m) dB(A)	Weight kg
ZEN BB 1000 A	4.020	0,873	3,87	66	39
ZEN BB 1500 A	5.360	1,164	5,16	67	55,5
ZEN BB 2000 A	8.040	1,746	7,74	68	78
ZEN BB 2500 A	9.380	2,037	9,03	69	94

ELECTRICAL HEATED						
Model	Airflow m³/h	Electrical Heating Capacity 400Vx3-50Hz kW	Power Fans 230V-50Hz kW	Current Fans 230V-50Hz A	Noise Level (5m) dB(A)	Weight kg
ZEN BB 1000 E	4.020	6'15'21	0,873	3,87	66	49,5
ZEN BB 1500 E	5.360	8'19'27	1,164	5,16	67	71,5
ZEN BB 2000 E	8.040	12'30'42 (*)	1,746	7,74	68	99
ZEN BB 2500 E	9.380	16'30'46 (*)	2,037	9,03	69	120

(*) 2 separated power supplies.

WATER HEATED													
Model	Airflow m³/h	P86			P64			P54			Current Fans 230V-50Hz A	Noise Level (5m) dB(A)	Weight kg
		Heating Capacity 80/60°C kW	Water Drop Pressure 80/60°C Pa	Heating Capacity 60/40°C kW	Water Drop Pressure 60/40°C Pa	Heating Capacity 50/40°C kW	Water Drop Pressure 50/40°C Pa	Power Fans 230V-50Hz kW					
ZEN BB 1000 P	3.750	16,48	12180	15,16	16190	18,21	15190	0,873	3,87	65	47,5		
ZEN BB 1500 P	5.000	24,15	15260	21,87	10990	26,46	10420	1,164	5,16	66	68,5		
ZEN BB 2000 P	7.500	35,04	12680	31,13	7350	38,44	10260	1,746	7,74	67	95		
ZEN BB 2500 P	8.750	42,12	11880	38,96	13420	46,38	9110	2,037	9,03	68	115		

Water heated:
 P86, P64 2x1", P54 1000-2000 2x1" and 2500 2x1¼".
 Connection pipes P86, P64 and P54 are female (male if lateral pipes).
 P86 2 rows coil, P64 3 rows coil, P54 4 rows coil.



Dimensions

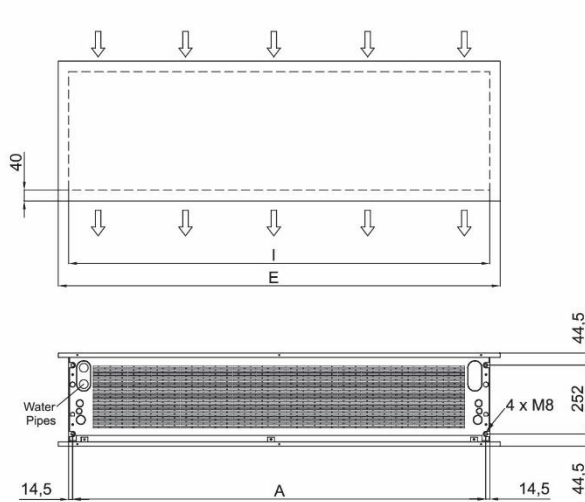

	E	I	A
ZEN BB 1000	1220	1140	1115
ZEN BB 1500	1620	1544	1515
ZEN BB 2000	2120	2044	2015
ZEN BB 2500	2620	2544	2515

Finishes





Vertical installation



- Painted any RAL colour or metal
- Different materials: aluminium, stainless steel AISI 304 (brushed or polished), wood, glass, PVC/PES, etc.
- Logos, lights, clocks, signs, vinyls, patterns, etc.



MAINTENANCE INSTRUCTIONS

	<i>For safety, before any cleaning, disconnect power supply using the controller.</i>
	<i>It is forbidden to open the service door (risk of electrical discharge and being trapped in fans). Service and maintenance should be done only by introduced and qualified workers.</i>
	<i>Do not use water or steam for cleaning the internal parts and components of the air curtain.</i>

External cleaning

Air curtains don't need any kind of maintenance except from the cleaning of the casing and the inlet grille. It is recommended to weekly clean the inlet grille. It's important to make sure that the air curtain is OFF, otherwise the dust mixed with a wet cloth would create a kind of paste that will damage the fan rotor when it sucks the air.

Annual cleaning of the discharge area (outlet).

The casing of the air curtain should be cleaned with a wet cloth and non-aggressive detergent. Do not use caustic soap or acids.

The inlet grille prevents the settling of dust and strange objects in the internal elements. It is recommended to check periodically that the inlet grille is free of any object that could interfere the air entrance (plastic bags, papers, etc.).



Internal cleaning

In models without micro drilled inlet grille and water coil or electrical heating is recommended to clean the inside of the unit with a vacuum at least once a year (*), best before the winter season, with qualified staff.

(*). These periods are indicative, depending on the ambient conditions of every installation.

In places with a high number of particles in suspension is desirable to increase the frequency of the internal cleaning (including the city centers, near construction sites, etc.).

REPAIRS AND REPLACEMENTS



Installation and electrical connections must be done by qualified workers and following these instructions.

Before any repairs are undertaken, please:



- **Inform people that there is work in progress.**
- **Disconnect the power supply and protect the thermal magnet (so nobody can restart it accidentally).**



- **Make sure there is no tension in the air curtain.**
- **Make sure the fans are stopped.**
- **Use only original spare parts.**

To **open the service door**, follow these steps:

1.- With a screwdriver and holding the service panel, remove the screws that fix it, placed on the top of the air curtain.



2.- Open the door carefully, in case you need to dismount it, remove the safety cables and move the door to one side to make it come out of position.



Some finishes can be fragile, manipulate the door gently and project it.

Fan replacement

Before replacing the fan, inform people that there is work in progress, stop the air curtain through the controller and disconnect main supply. Make sure that the unit is without tension and the fans are stationary. Unplug the fan from the cable tree. Remove the fan by loosening the fixing screws and assemble the new fan following the process in reverse order.



Fuse and PCB replacement

Before the replacement, inform people that there is work in progress.

Disconnect main supply, make sure that the unit is without tension and that the fans are stationary.

Fuse replacement: Open the service panel and remove the fuse of the fuse holder by hand or pulling with the help of a screwdriver pressing to the plate and turning in under clockwise, then replace it.



PCB replacement: Open the service panel and simply unscrew the power plate from the inside of the air curtain to remove it and make the necessary repairs.



Heater replacement

Before the replacement, inform people that there is work in progress, disconnect main supply, make sure that the unit is without tension and that the fans are stopped. Before proceeding to unfasten the heater fixing screws, we must:

Water Coils: Close the shut-off water valves of the building water circuit to the air curtain (supply and return). Open the service door and empty the water from the coil simply removing the draining screw placed in the bottom of the entrance manifold as shown in the photograph.



Electrical Heaters: Disconnect the power supply from the electrical element.

When we have the coil or heater ready, we proceed to remove the fixation screws to disassemble the coil or heater and assemble the new heater following the same process in reverse order.



Remove the screw-earth of the connection box and disassemble from the equipment.



Unplug the cables to 1, 2, 3 in the connection box.

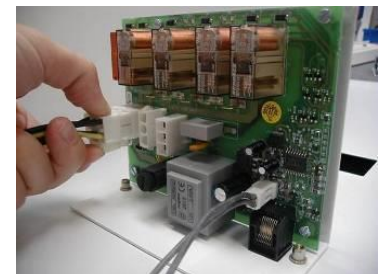

Unplug the two connectors of plate pressing the fluke.

Open the service door, remove the screws of the water coil or electrical heater and remove it

After opening the service door, we proceed to remove the heater according to the following steps. First, extract the rubber caps and remove all screws which fasten the inlet grille. Now you can remove the grille.



Then, unscrew all the screws from the selected support according to the pictures



Afterwards, unfasten the 2 side covers. In case of vertical installation, you must remove 1 side cover and the foot support.

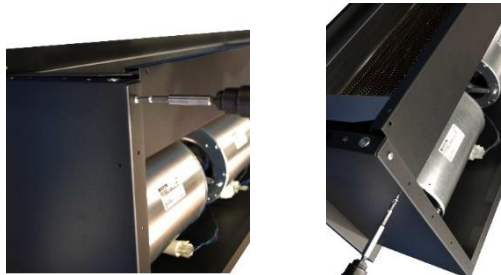

For ZEN 2000 and 2500 models, you also have to loosen the middle reinforcement rod support.



To end, the heater is fastened by these little angles. Once unscrewed, we can extract the heater. Now, we can do the repairing or replacing the heater following the reverse process.



Loosen and rotate all the flukes that hold the coil or heater.

FAILURES AND SOLUTIONS

More than 95% of the complaints are submitted during the start of operation of the equipment and are due to installations errors.

More than 90% of the failures are solved only by **checking the connections**. Following the three following points, we can make sure that the installation is correct:

A) RJ45 cable manipulated: The cable that connects the controller to the air curtains is an 8 lines crossed RJ45 cable. **If manipulated (cut or removed the connector) and incorrectly joined (reverse way) the air curtain will not work well.** Moreover it can damage the electronics. To solve the problem just turn the connector of the cable (see connection diagram in the first page).

B) Wrong connection of the RJ45 cable. Verify whether the connector position is the correct, between the “control” and “auxiliary”, according to the installation diagram (particularly if there are several air curtains with a single controller).

C) Wrong current supply/input. The air curtain input depends on the type of current available and also on the heating type of the unit. Connect the unit according to the connection diagrams of the first page.

More common failures and solutions		
Effect	Problems	Solutions
All lights of the controller are OFF	Is the RJ45 cable the original (not manipulated), with no enlargements either shortenings?	Change the cable or connect it again correctly.
	Does the current reaches the connection box?	Connect correctly the terminals of the junction box: Between L and N there must be 230V and if the air curtain goes with three-phase electrical element, there must be 400V among terminals L1, L2 and L3.
	Is the controller connected to the air curtain, to the connector “Control” of the PCBoard?	Connect the cable from the controller to the “Control”, never to the “Aux”.
	Is the fuse of the PCBoard in good conditions?	Check the fuse and replace it in case it is necessary (type T, slow action).
Some lights of the controller are Flashing.	The green LED of the maximum speed flashes when we stop the air curtain after having been operating with heating.	It is not a failure, but a safety mechanism. The air curtain turns on by itself to the maximum speed to get cold and protect its components. When it decreases from the safety temperature, it will stop.
	Some speed or heating lights are flashing when the air curtain is working.	It is a protection mechanism of the air curtain so that the internal parts of the air curtain do not suffer damages. Situations on which the problem continuously recurs and the way to solve it: 1. Inlet grille blocked (objects, dirtiness...) the ambient temperature inside the equipment can increase a lot if the air cannot circulate. Clean the grille. 2. Small room: we recommend installing a thermostat to control the heating power so the protection device do not activates. 3. In case that the ambient temperature is already high, we recommend to lower the power heating or install a thermostat. 4. Inlet air already warm, that comes from another heating equipment beyond the air curtain. Move the air curtain away, place a thermostat in the inlet part of the curtain or lower the heating power. 5. Any motor does not work: call the technical service.
The heating does not work	Does the three-phase current reach the connections box?	Check installation.
The speed and/or the heat changes continuously with no apparent reason but the lights of the controller are not flashing.	Probably the RJ45 cable is near interference sources, transmitters, cable plates, particularly those that supply current to Motors, etc.	Pass the cable the furthest possible away from interference sources, particularly when long distances or use a screened table.

ACCESSORIES



External temperature Sensor

It permits to take the temperature from a place different to the control.

Supports, feet, vibration dampers, etc. depending on the model.

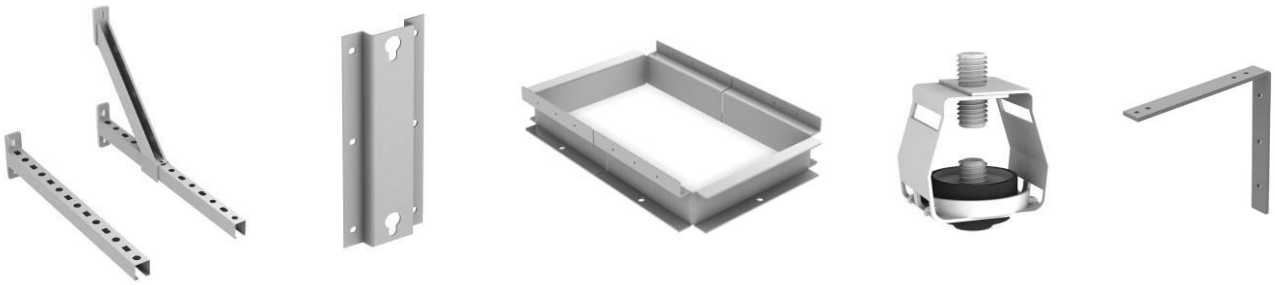

Door contact, thermostatic valve, solenoid valve, antifreezing sensor, etc.



RJ45 Cable 20m and 50m



DECLARATION OF CONFORMITY



Declaration CE of conformity / Declaración CE de conformidad

Manufacturer **Motors i Ventiladors S.L. (AIRTECNICS)**
Fabricante **Conca de Barberà 6, Pol. Ind. Pla de la Bruguera**
08211 Castellar del Vallès (Barcelona) Spain

We declare, under our sole responsibility, that the product
Declaramos, bajo nuestra única responsabilidad, que el producto

Air Curtains
Cortinas de aire

with models
con los modelos

Minibel, Optima, Recessed Optima, Optima Wireless, Recessed Optima Wireless, Windbox, Recessed Windbox, Smart, Dam, Deco, Kool, Variwind, Rotowind, Invisair, Rund, Zen, Triojet System, Duojet, Max, Recessed Dam, Recessed Compact, Maxwell, Windbox BB, Recessed Windbox BB, Zen BB, Compact Fly, Aris, Fly K, Fly KL-KXL, Fly KBB, Windbox L-XL.

is/are developed, designed and manufactured in accordance with the following directive(s)
ha(n) sido desarrollado(s), diseñado(s) y fabricado(s) de acuerdo con la(s) siguiente(s) directiva(s)

Low Voltage Directive 2014/35/UE
Directiva Baja Tensión 2014/35/UE

Electromagnetic Compatibility Directive 2014/30/UE
Directiva Compatibilidad Electromagnética 2014/30/UE

Restriction Certain Hazardous Substances Directive 2011/65/EU (RoHS)
Directiva Restricción Substancias Peligrosas 2011/65/EU

Eco-design Energy-related Products Directive 2009/125/EC
Directiva Diseño Ecológico Productos Con Energía 2009/125/CE

applying the following harmonized standards in particular
aplicando las siguientes normas armonizadas en particular

LVD: EN 60335-1:2012 / AC:2014 / A11:2014 / A13:2017 / A:14:2020
EN 60335-2-30:2010 / A11:2012 / A1:2020

EMC: EN 61000-3-11:2002
EN 61000-3-12:2012
EN 55014-1:2017
EN 55014-2:2015

RoHS: EN 50581:2012

Date / Fecha
Name / Nombre
Position / Cargo

13/07/2020
Jordi Hierro
Technical Manager / Director Técnico

AIRTECNICS EXPORT, S.L.
C/Conca de Barbera, 5 - Pla Bruguera
08211 CASTELLAR DEL VALLES
Tel. +34 93 714 36 36
CIF: ESB66276171



Model <i>Modelo</i>	WINDBOX M 2000 E			
Airflow <i>Caudal</i>	3600	m3/h		
Blowers <i>Ventiladores</i>	1,88	A	0,424	kW 230 V/50Hz
Heating capacity <i>Calefacción</i>	80/60 °C		60/40 °C	
Water Coil <i>Agua</i>		kW		kW
Electric Coil <i>Batería Eléctrica</i>	6/12/18	kW	400V~3 50Hz	
Serial Number <i>Número de Serie</i>	2015-07-06 / 61.990			

Air curtain identification

Each air curtain is identified by a unique serial number printed in a label located inside the door service. There is also indicated the model and their technical characteristics (flow, fans technical characteristics and power heating).

It is indispensable to have this number to facilitate possible replacements or technical information of the air curtain in question.

If you detect some error in this manual, we'll be pleased to receive your *feedback*, it helps us to improve even more.

Airtècnics reserves the right to modify some of the specifications in this manual.

GUARANTEE

Your air curtain is guaranteed for a period of one year from the date of purchase. We will adjust, repair or replace at our discretion from our warehouse any defect, system failure or part found to be defective. The assembly cost out of our warehouse is at buyer expense. The products that, in our eyes, have been inadequately used, incorrectly manipulated, improperly installed, connected to different nominal tensions, modified, repaired by non-authorized workers or that have suffered damages during transport are totally excluded from the guarantee.

To validate the guarantee it should be correctly filled and enclosed with the invoice that vouches for the buying date. If it is manipulated, it will lose all validity.

It is the buyer's responsibility to take the necessary safety measures because in case of a failure or mistake in one of our products, no damages to third parties, sets or installations will occur.

✂ -----

Guarantee draft

Air curtains data:

Model: Series number:
 Invoice date: Invoice number:

Buyer data:

Name:
 Address:
 Country: Phone: Fax:

Seller data:

Name:
 Address:
 Country: Phone: Fax:

Buyer signature and stamp

Seller signature and stamp