

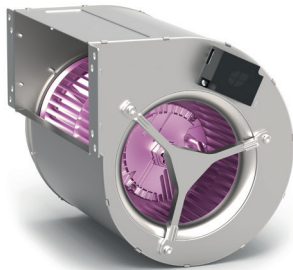

Characteristics

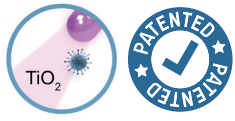

- Kleefan technology with photocatalytic disinfectant action fans.
- Photocatalysis starts from the natural principle of decontamination of nature itself. It is a natural phenomenon that, mimicking photosynthesis, accelerates a photoreaction through the action of light on a catalyst.
- UV-A rays, from the long-life LED, act on the titanium dioxide in the turbine generating Reactive Oxygen Species (ROS) that cause advanced oxidation processes (AOP), deactivating a wide range of pathogenic microorganisms (viruses and bacteria).
- This catalytic reaction produces oxidation reactions in organic compounds and reduction in inorganic ones, in addition to significantly reducing suspended particles.
- Mineralizes most of the pollutants present in urban areas produced by vehicles and industry (NOx, SOx, COx, formaldehydes, VOCs, etc.).
- Double-inlet EC centrifugal fan driven by an external rotor motor of low consume protected through thermal contact 0-100% variable speed.
- Optional: electronic speed regulator PM3 0-10V with integrated ON / OFF switch, to be built into the wall.

Specifications

Model	Airflow m³/h	Fan Power 230V-50Hz W	Fan Current 230V-50Hz A	Noise Level (5 m) dB(A)	Weight kg
KLEEFAN	900	138	1,06	59	3,5

Dimensions

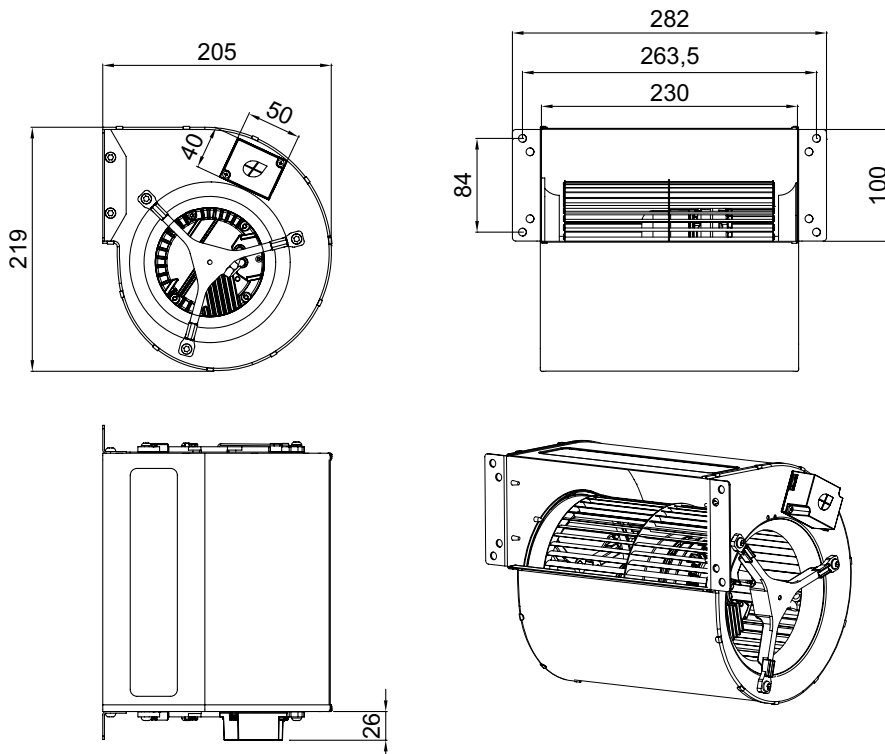



Performance curve

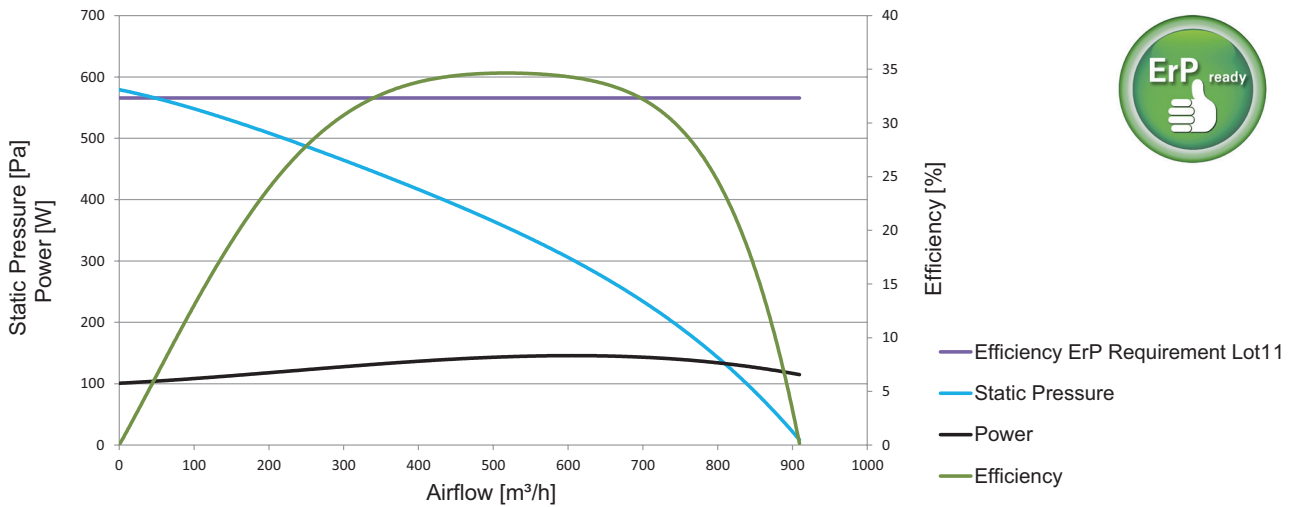

Efficiency test

The photocatalytic disinfectant technology has been tested effectively against formaldehydes, volatile organic compounds and particles by the Research Center for Food Safety and Control (CRESCA) of the Polytechnic University of Catalonia. The Kleenfan test results indicate a substantial improvement in air quality with just one pass through the fan, regardless of recirculation. They reflect a reduction efficiency of PM10, PM2.5 and PM1 airborne particles higher than 96% with a single circulation through the fan. Kleenfan reduces volatile organic compounds (VOCs) by more than 70%. Furthermore, this oxidizing technology is perfect for deodorization, with a reduction of more than 65% of formaldehyde, one of the main indicators for the elimination of odours.

