

Air Curtain with Heat Pump MITSUBISHI ELECTRIC



INSTALATION, OPERATION AND MAINTENANCE MANUAL

**Air curtains with Slave DX control and Heat Pump
Mitsubishi Electric 1:1&VRF system**

**With HEATING and COOLING:
Windbox, Recessed Windbox, Smart, Dam and Recessed Dam with
Mitsubishi Electric Pump and Kit (*)**

**Only HEATING:
Invisair, Rotowind, Rund and Zen with Mitsubishi Electric Pump (*)**



Please, reed these instructions carefully before attempting installation

SECURITY ADVISE SIMBOLS



Attention, Danger, Safety Advice!



Danger from electric current or high voltage!



Injuries risk!



Danger! Do not stay underneath: Heavy load.



Important information.

(*) This manual complements with the Mitsubishi Electric Kit PAC-AHxxxM-J (VRF) or PAC_IF013B-E (1:1)



This manual indicates how to connect the air curtains with the heat pump external unit. It is necessary to complement this information with the heat pump manufacturer manual for a correct installation and maintenance of the set.

INDEX

CAUTIONS.....	3
INSTALLATION	4
CONNECTION DIAGRAM.....	11
CONNECTIONS	12
TRANSPORTATION AND STORAGE	14
OPERATING INSTRUCTIONS.....	15
AIR CURTAINS WORKING MODE	20
WIRING DIAGRAMS	20
DATASHEET.....	21
MAINTENANCE INSTRUCTIONS	30
REPAIRS AND REPLACEMENTS	36
TROUBLESHOOTING	42
ACCESSORIES.....	44
DECLARATION OF CONFORMITY	45
IDENTIFICATOR	46
GUARANTEE	46

CAUTIONS

IMPORTANT INSTRUCTIONS

Please before installing or using the air curtain, read carefully all instructions and considerations to reduce the risk of fire, electric shock, injury to people or damage to the air curtain itself. For that is recommended to follow the next basic precautions:

1. Use the air curtain only in the manner intended by the manufacturer and described in this manual. Any other use not recommended may increase the risks mentioned before.
2. Installation work and electrical wiring must be done by a qualified technician. Be also careful to not damage electrical wiring or hidden utilities when cutting or drilling into a wall or ceiling.
3. All air curtains with heat pump include a precharge of 4 to 6 bars of nitrogen. Discharge the pressure before performing the installation connections.
4. The air curtain is a heavy appliance and for that matter it must be elevated with proper lifting tools to prevent injuries to the people who install it.
5. Before servicing or cleaning the unit, switch power off at service pannel and lock the service disconnecting the means to prevent being switched on accidentally. When the service protection elements cannot be locked, securely fasten a prominent warning device, such as a tag, to the service panel.
6. It's HIGHLY recommended to do a periodical maintenance as stated in this manual section following the instructions given to clean the inlet grille, visual inspect each part and prevent any possible malfunction or issue of the air curtain before it happens.
7. Do not operate any air curtain after it malfunctions. Disconnect power at service panel and have air curtain inspected by a qualified technician before reusing.
8. To disconnect the air curtain, turn the control "OFF", wait 10 minutes for the device to stop completely and then turn off power supply to the air curtain.
9. The air curtains with heating are hot when in use. To avoid burns, do not let bare skin touch hot surfaces. Keep combustible materials, such as furniture, pillows, bedding, papers, clothes, etc at least 3cm (1 inch) from the top, back, front, sides and at least 180cm (6 feet) from the discharge of the air curtain.
10. To prevent a fire, do not block the air intake or discharge of the air curtain in any manner. Also prevent any foreign objects to enter any ventilation or exhaust opening as it may cause an electric shock, fire or damage the air curtain.
11. The air curtain has hot and may have arcing or sparking parts inside. Do not use it in areas where gasoline, paint or flammable vapors or liquids are used or stored.
12. Extreme caution is necessary when any air curtain is used by or near children, elderly or invalids, and whenever the air curtain is left operating unattended.
13. Some air curtain may include a visual alarm to warn that parts of the air curtain are getting excessively hot. If the overheating alarm is active because inside the temperature is rising too much, then the air curtain protects itself changing the functioning by increasing ventilation speeds and/or reducing heating stages. Check Troubleshooting part in this manual for more info about how to proceed.
14. Air curtains must not be installed outdoors unless is intended for outdoor use. If so, the air curtain should be always protected against rain and it's recommended a special protection to prevent corrosion and other issues caused by the environment (optional).
15. The optimal working temperature of the fans is between 5°C and 40°C (41°F to 104°F) to protect the electrical components and at most should not exceed 50°C (122°F).

SAVE THESE INSTRUCTIONS

INSTALLATION

Tips and recommendations for a good installation

LENGTH

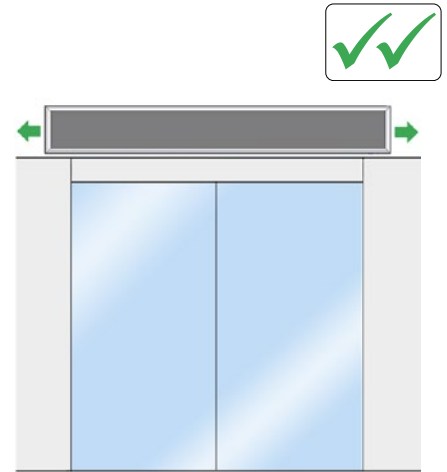
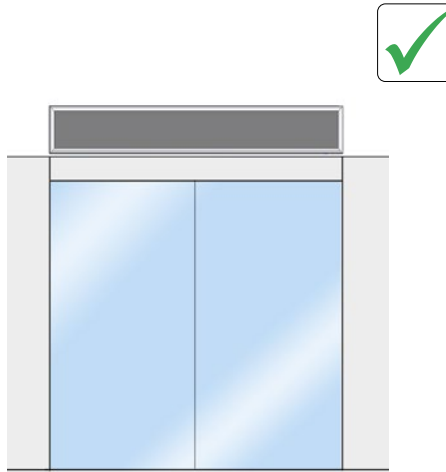
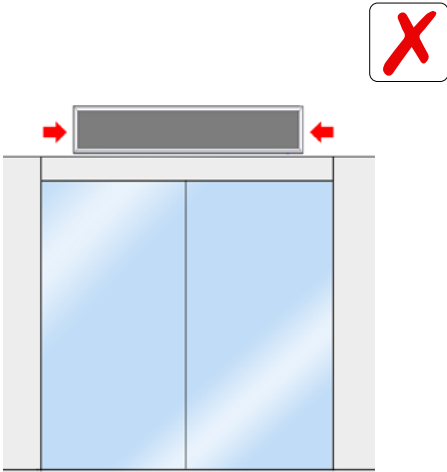

CENTERED / HEIGHT

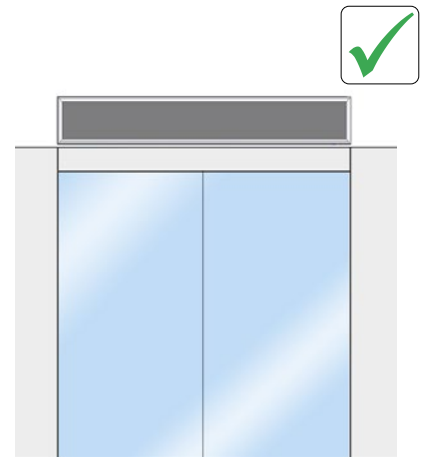
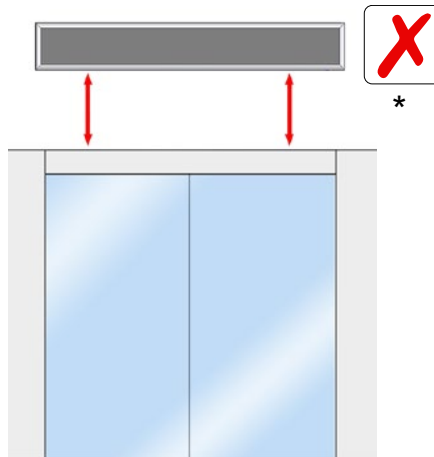
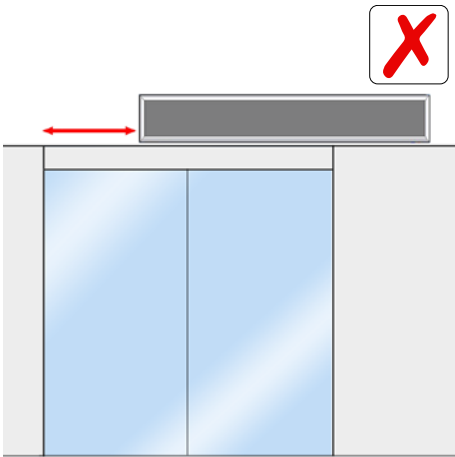

(* Unless it has been designed to be installed at that height.

DOOR DISTANCE

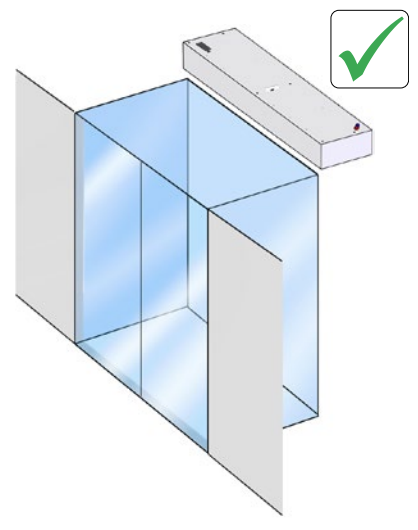
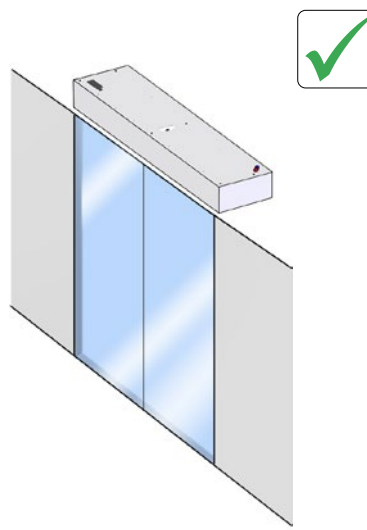
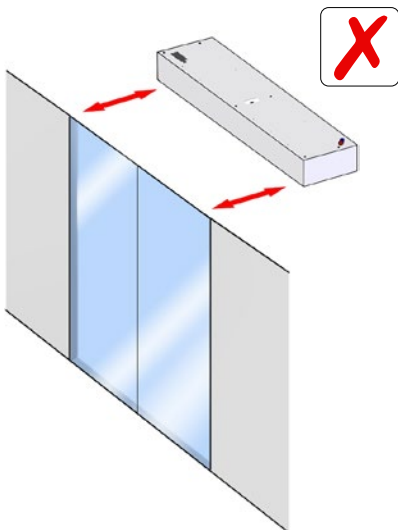



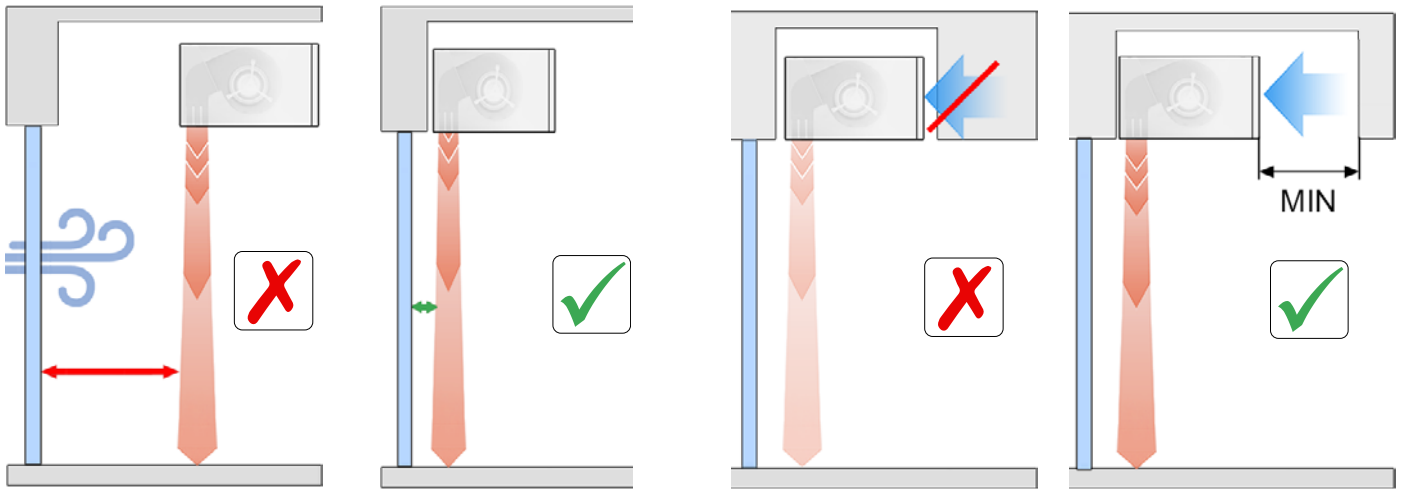

AIR DISCHARGE

AIR ASPIRATION

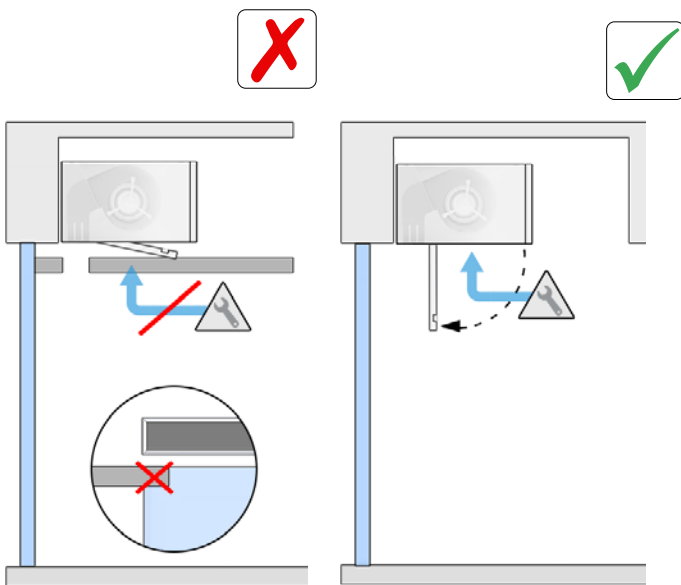

MAINTENANCE ACCESSIBILITY



	<p>Installation work, connection, disconnection, electrical wiring, maintenance and service must be done by qualified people observing these instructions and in accordance with all applicable norms and standards.</p> <p>If the unit is operated with additional controller, please consider its specific instructions.</p>
	<p>For manipulation safety, being it assembling, transport or maintenance duties it's a must to wear the correct individual protection equipment recommended. Those being gloves, insulating shoes, goggles and helmet.</p>
	<p>There is no need to open the service door to connect the air curtain. All connections of power supply, control, DX pipes (when the model is a heat pump) and fixations are external. They are placed on top of the units. Depending of the model, inside of them may be auxiliar connectors like temperature sensors, electrovalves, etc.</p>
	<p>For safety, the air curtains never have to be stopped by disconnecting them from the main supply, always through the controller and waiting 10 minutes at least to disconnect the main supply. In case to not follow these instructions, the internal parts of the air curtain can be damaged.</p>

Windbox Model

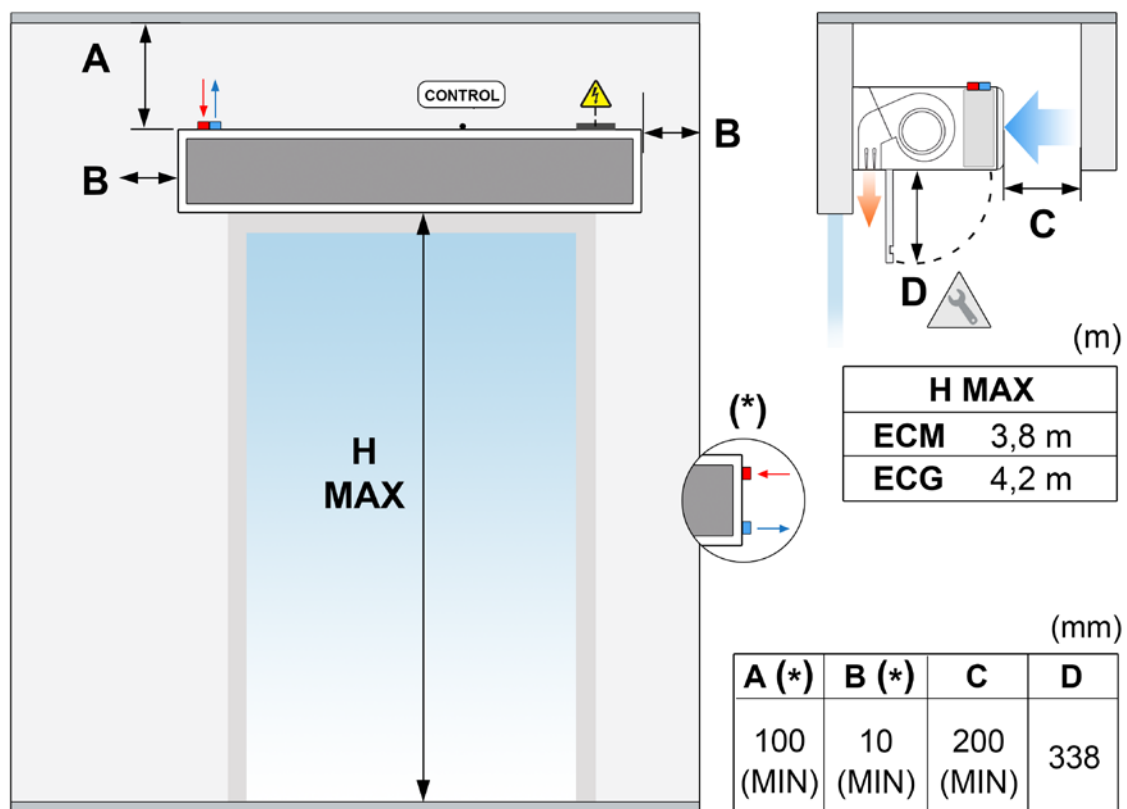

H MAX. Maximum recommended range, MIN. Recommended minimum distance.

(*) Standard units. Under demand, this distance can be reduced to 10 mm when the connections are located inside the air curtain and the pipes outlet are on the side. In this case the distance B will be of 100 mm.

The minimum recommended distance between the suction grille and any obstacle is 200 mm (Dimension C).

Dimension D: service opening distance.

DAM Model

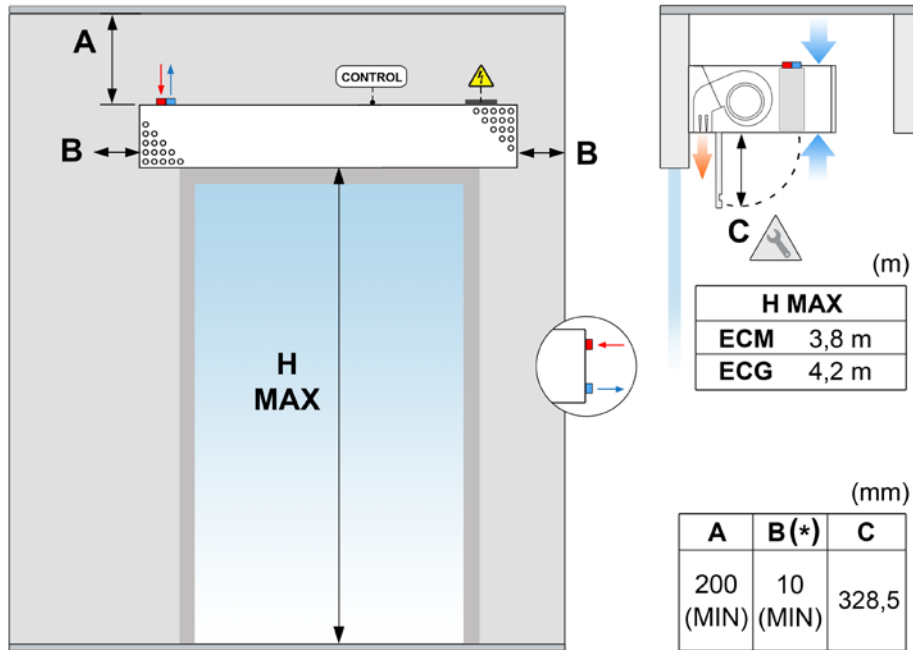

H MAX. Maximum recommended range, MIN. Recommended minimum distance.

(*) Standard units. Under demand, the distance "B" will be modified to 100 mm when the outlet of pipes is located on the side.

The minimum recommended distance between the suction grille and any obstacle is 200 mm for air curtains DAM (Dimension A).

Dimension C: service opening distance.

Recessed Windbox Model

H MAX. Maximum recommended range, MIN. Recommended minimum distance.

(*) Standard units. Under demand, this distance can be reduced to 10 mm when the connections are located inside the air curtain and the pipes outlet are on the side. In this case the distance B will be of 100 mm.

The minimum recommended distance between the suction grille and any obstacle is 200 mm.

Dimension C: service opening distance.

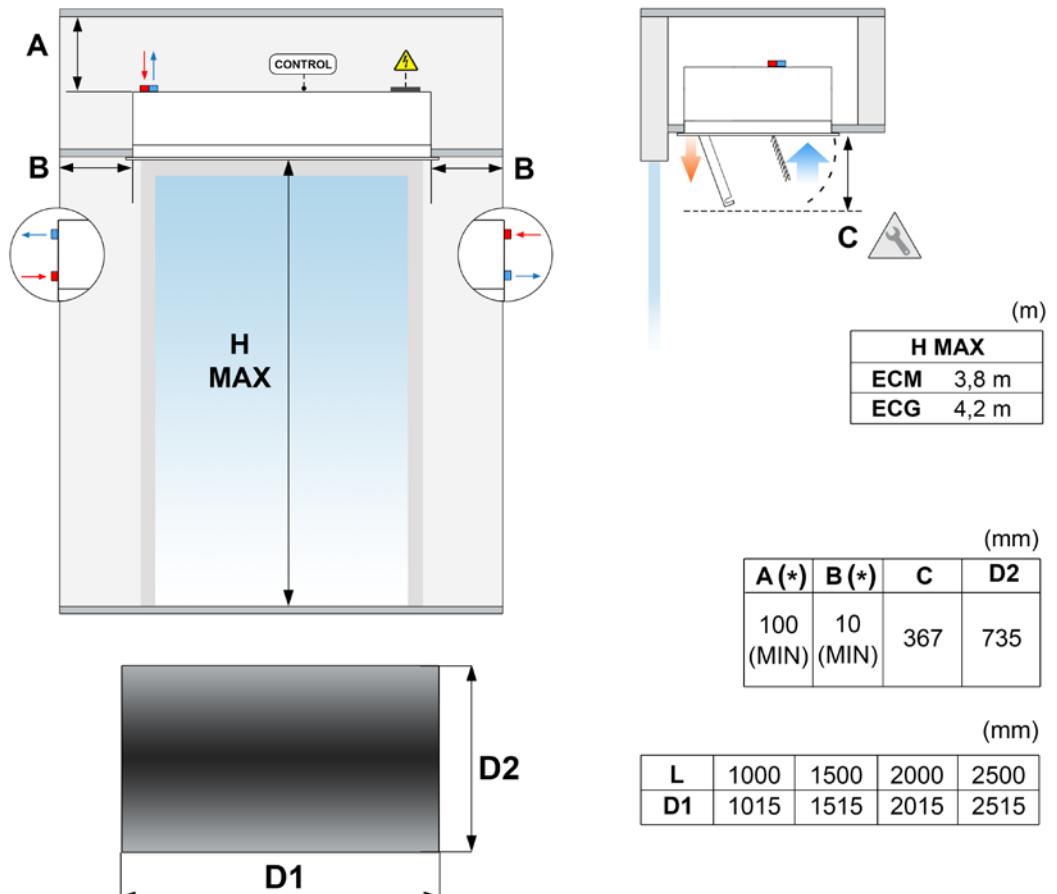

Recessed DAM Model

H MAX. Maximum recommended range, MIN. Recommended minimum distance.

(*) Standard units. Under demand, this distance can be reduced to 10 mm when the connections are located inside the air curtain and the pipes outlet are on the side. In this case the distance B will be of 100 mm.

The minimum recommended distance between the suction grille and any obstacle is 200 mm (Dimension C). Dimension D: service opening distance.

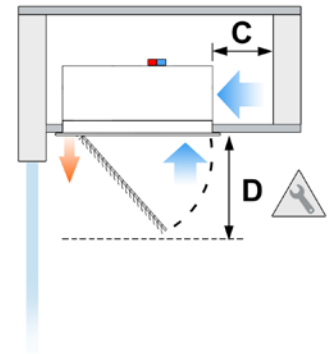
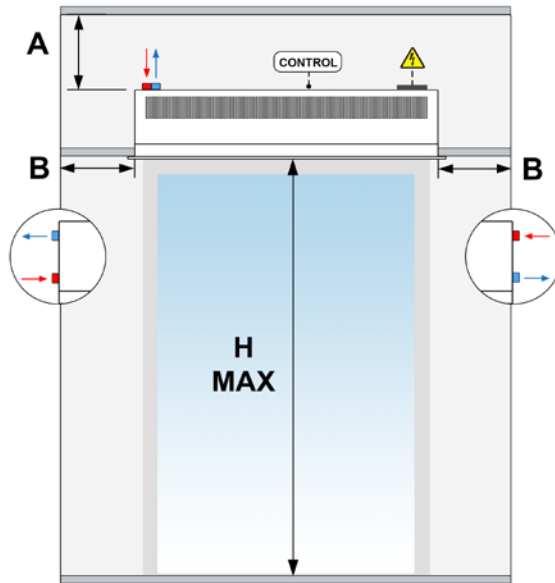

H MAX (m)	
ECM	3,8 m
ECG	4,2 m

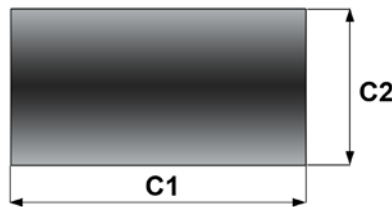

(mm)				
A (*)	B (*)	C	D	C2
100 (MIN)	10 (MIN)	200 (MIN)	532	595

(mm)				
L	1000	1500	2000	2500
C1	1015	1515	2015	2515

Invisair Model

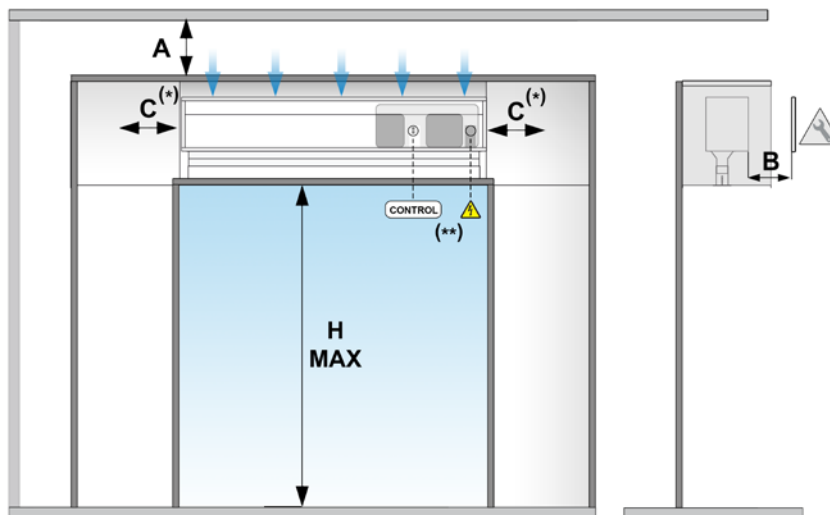

H MAX (m)	
ECG	4,2 m

(mm)					
A	B	C(*)	L1	L2	L3
200 (MIN)	250 (MIN)	10 (MIN)	1500	200	100
			2000		
			2500		

H MAX. Maximum recommended range, MIN. Recommended minimum distance.

The minimum recommended distance between the suction grille and any obstacle is 200 mm (Dimension A).

(*) Standard units. Under demand, the distance "C" will be modified to 100 mm when the outlet of pipes is located on the side.

Dimension B: service opening distance.

Smart Model

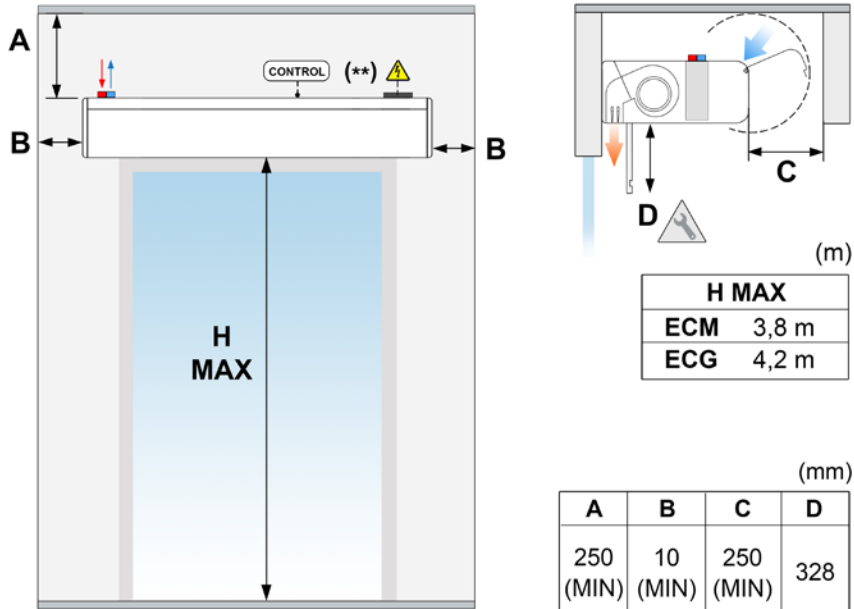

H MAX. Maximum recommended range, MIN. Recommended minimum distance.
 The minimum distance to open the front panel is 250 mm (Dimension C).
 Dimension D: service opening distance.

Zen Model

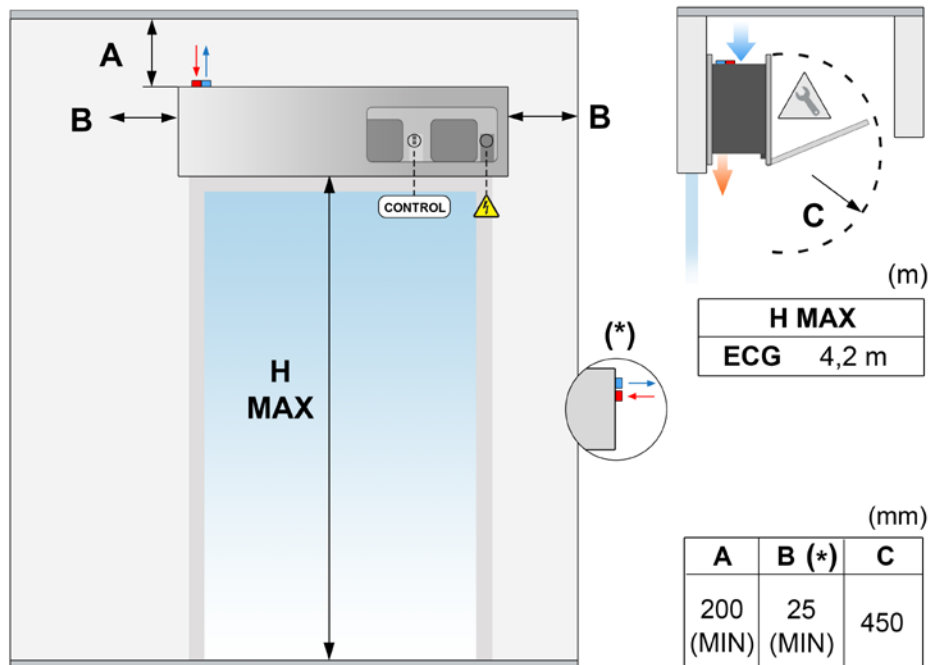

H MAX. Maximum recommended range, MIN. Recommended minimum distance.

(*) Standard units. Under demand, the distance "B" will be modified to 100 mm when the outlet of pipes is located on the side.

The minimum recommended distance between the suction grille and any obstacle is 200 mm (Dimension A).
 Dimension C: service opening distance.

Rund Model

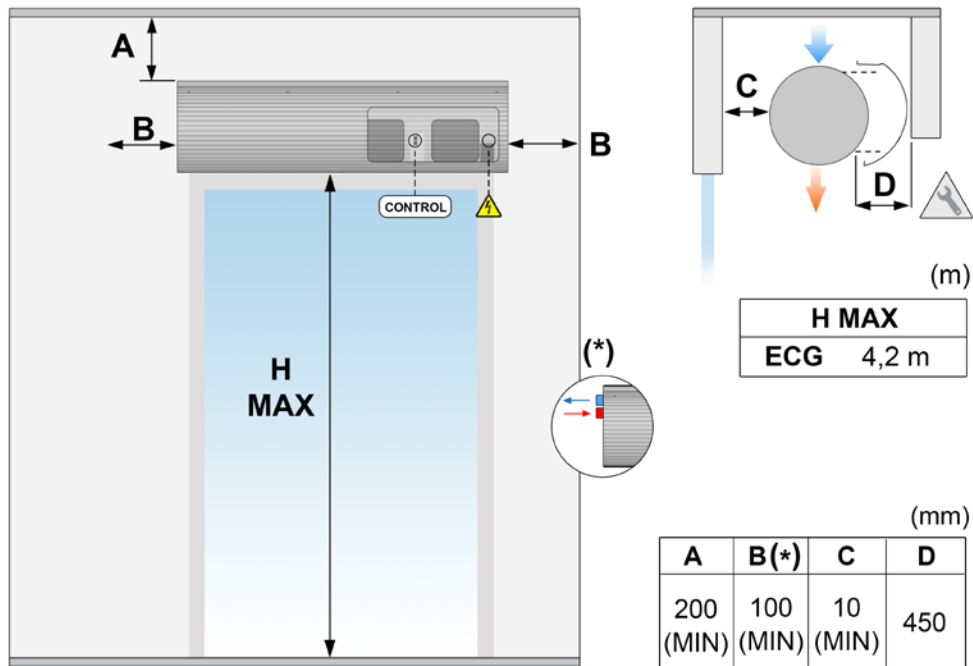

H MAX. Maximum recommended range, MIN. Recommended minimum distance.

(*) Standard units. Under demand, this distance can be reduced to 10 mm when the connections are located inside the air curtain and the pipes outlet are on the back part. In this case the distance C will be of 100 mm. The minimum recommended distance between the suction grille and any obstacle is 200 mm (Dimension A). Dimension D: service opening distance.

Rotowind Model

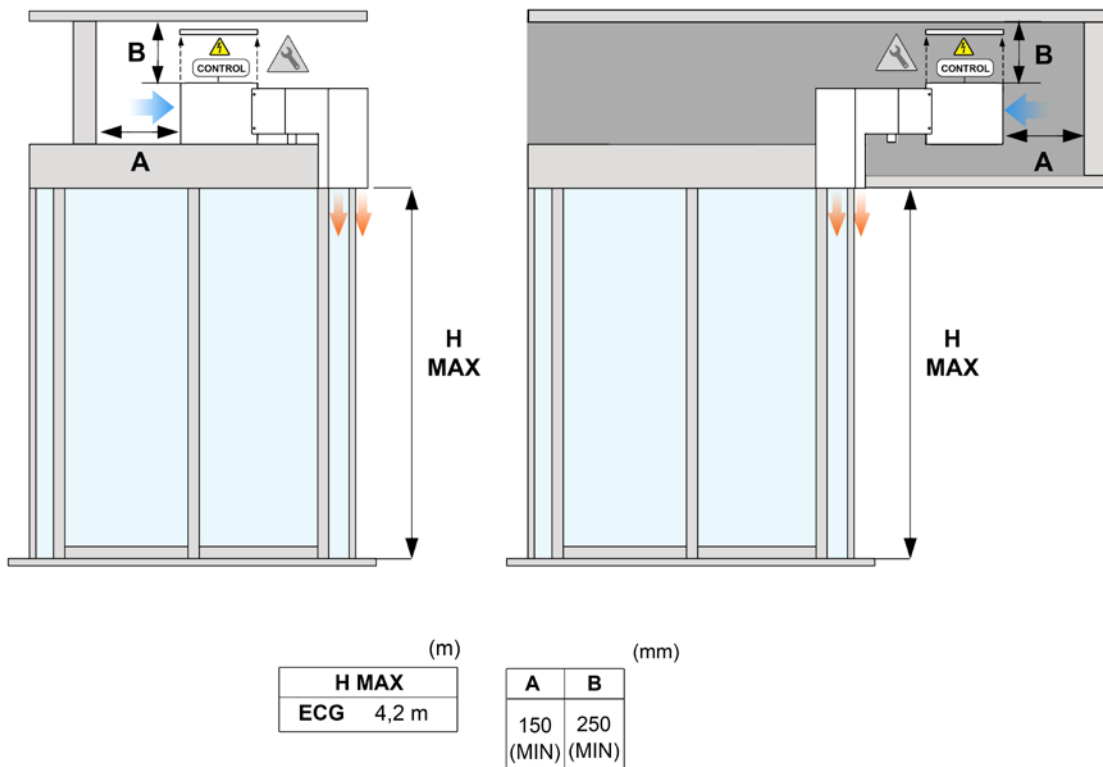

H MAX. Maximum recommended range, MIN. Recommended minimum distance.

The minimum recommended distance between the suction grille and any obstacle is 150 mm (Dimension A). Dimension B: service opening distance.

CONNECTION DIAGRAM

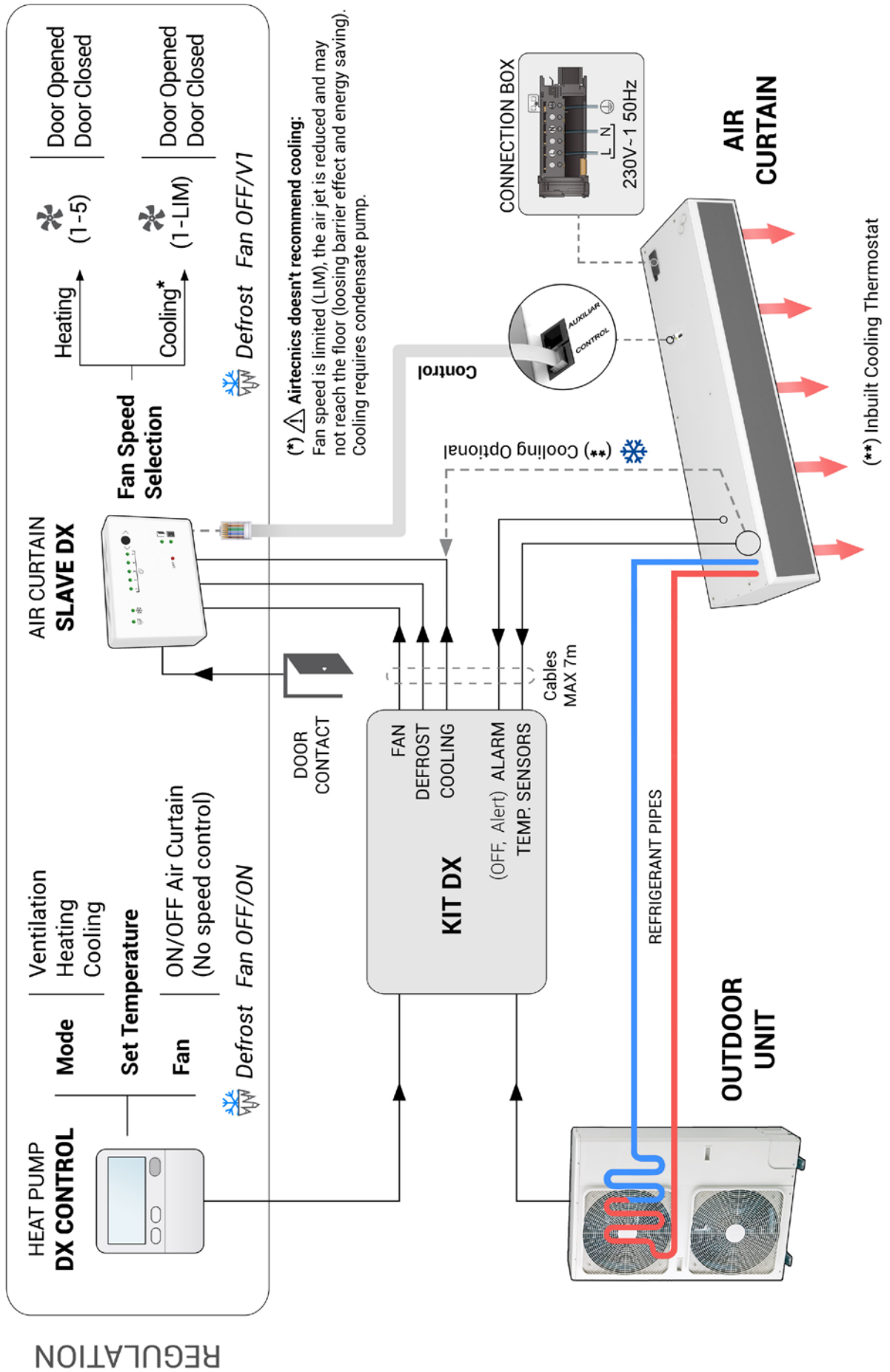

CONNECTIONS

Power Supply

Air Curtain: to connect the power supply there is a black connection box located on the outside of the air curtain except for the Rund and Zen air curtain models, which is located inside. The standard power supply is 230Vx1.

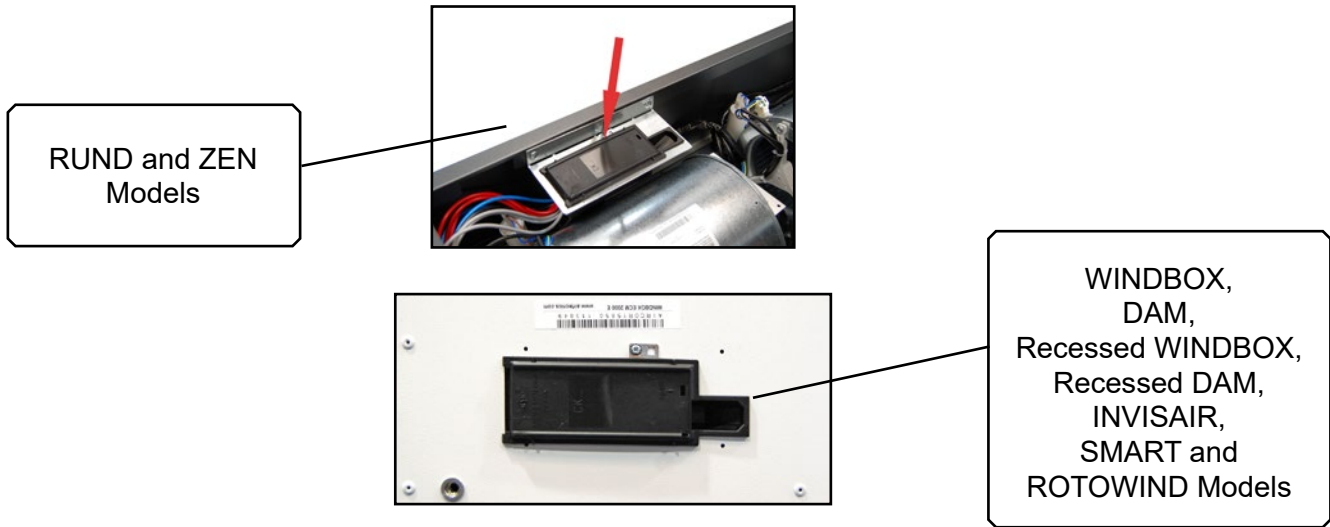

Only the single-phase 230V power supply is required to operate the fans.

The recommended maximum number of air curtains connected to the same differential is:

Model	Differential 30mA	Differential 300mA
ECM-ECG	2 uds.	20 uds.

Each installation must be checked by a specialist to verify that there is no incompatibility between the selected electrical protections and the connected air curtains.

Kit DX: Follow Mitsubishi Electric's own instructions for connection.

Outdoor unit (condenser): Follow the instructions of each condenser unit to connect the power supply. The voltage can be of 230Vx1 or 400Vx3 depending on the model.

Condensate pump (applicable only in models with cool): It is the pump to empty the condensate tray and must be connected to 230Vx1. Moreover, it has two connections for water pipe. The inlet is connected to the condensate tray and the outlet to the waste pipe. It is optional but highly recommended for cold working models.

Control

Airtècnics Air Curtains: Connect the Slave DX to the "control" connector placed in the curtain using the RJ45 cable (included). Each model has it's own way to connect the control device:

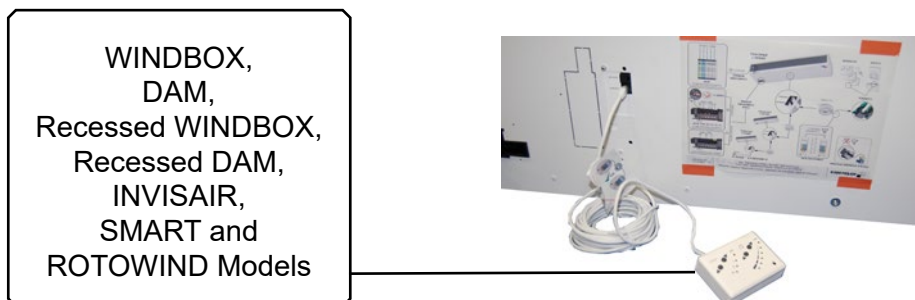



RUND and ZEN Models

Airtècnics Slave DX Control:

All contacts must be free voltage.

- o *Door contact:* Connect the door contact to “+” and “T” of the Slave DX. If not installed, it works as open door.

- o *ON/OFF contact:* Connect the output FAN (“K3” and “K4”) of the Mitsubishi Electric kit to the terminals “1” and “2” of the Slave DX. When the contact is closed, the fans of the curtain turn on.

- o *Defrost contact (optional):* Connect the output Defrost (“K7” and “K8”) to the terminals “+” and “F” of the Slave DX. The Mitsubishi Electric DX-kit needs to be configured so the fans don’t stop while the defrost is active. To do so, the contact ON must be modified and then connect it to the Slave DX to select what the air curtain should do while in defrost:

- Stops.
- Keeps working but at the lowest speed.
- If it’s needed to keep the fans work while defrost, then don’t connect the defrost to the Slave DX.

- o *Cooling contact (only for curtains with cooling and heating):* Connect the cooling signal to the Slave DX input as is shown at the wiring diagram. By default, the sensor is connected to the PCB which limits the 3rd fan speed, but if the user wants to change the speed, then disconnect the sensor from the “TR” connector from the PCB and connect it to the Slave DX (“+”, “R”). In both cases, the fan speed is limited to 2,5 m/s to avoid water dragging.

One of the two options should be done for air curtains with cooling. If not, the water can cause several damages which the guarantee does not cover.

Kit-DX Mitsubishi Electric: Controls the functioning of the external heat pump unit and it should be installed close to the air curtain. It sends orders and communicates with the air curtain Slave DX.

For 1:1 systems it’s not needed to modify the capacity.

To modify the capacity in VRF systems, it’s needed to follow this table:

PAC	Unit - Heating Capacity	Air Curtain DX	Switches (On/Off state)	
			SW2	SW3-2
AH125	P100 10-12,5kW	DX12		
	P125 12,5-16kW	DX14,15,16		
AH250	P200 18-25kW	DX22, 24, 25		
	P250 25-31,5kW	DX27, 28, 29, 30, 32		

Mitsubishi Control: Connect to DX kit. The Mitsubishi control decides the mode (air, heating and, in curtains prepared for that, in cooling) and the Set temperature. The air curtain only can work when the Mitsubishi Electric control is ON.

Mitsubishi Electric's outdoor unit: Connect it with the DX kit according to the wiring diagram.

Condensate water pump: Mandatory on cooling models. If not installed, it may result in water damage to the unit (not covered by the guarantee) or to the building. Airtècnics optionally provides a condensate pump with a hose cable of 3 pins for the power supply of the condensate pump.

Fixings

The air curtain has several external fastening points depending on the weight and length (see situation in the model characteristics section).

Generally, air curtains are installed horizontally. The anchor must be sized according to the weights of each air curtain indicated on the technical data page. The installation can be done using threaded rods, tensioners or other supports (see available supports in the accessories section).

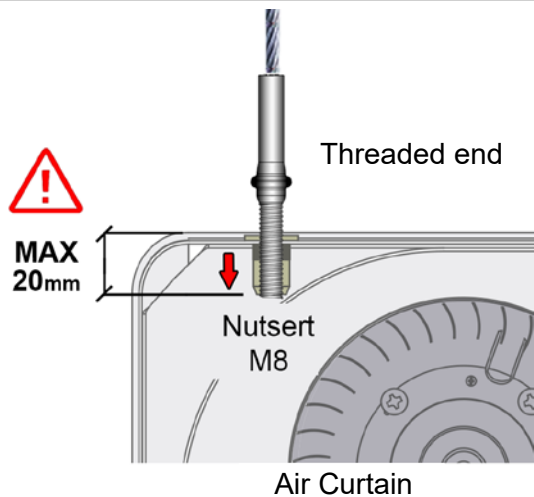

TRANSPORTATION AND STORAGE

	<p>Warning! Heavy load. Do not stand under the suspended load during transportation or assembly.</p>
-------------------------------------------------------------------------------------	------------------------------------------------------------------------------------------------------------------------

Store in a dry place protected from the environment. If the package is opened, cover the air curtain to protect it from the dust. Do not step on or place heavy loads on it to avoid damage to the material. Storage temperature between -20 °C and +40 °C.

When transporting the material, be sure to use the recommended tools to move and lift heavy parts to prevent injuries or damages. Also you must ensure that it is not damaged by the forklift. (possible penetration of the fork in the packaging). Observe the instructions on the packaging for correct manipulation of the product.



OPERATING INSTRUCTIONS



For safety, the air curtains must never be stopped by disconnecting the current, always do it through the control. If the power is turned off to turn off the air curtain, or within ten minutes of turning it off with the control, internal components may be damaged.

Characteristics of regulation boards

Depending on the fan type, the air speed is regulated by:

- EC (ECM - ECG): voltage variation from 0 - 10V DC.

Characteristics of the Slave DX

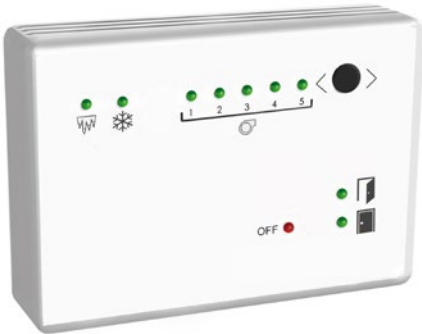

Controller Slave DX (CS-5DX-NE) is specially designed for air curtains with direct expansion coils.

This controller works in slave mode. When the control of heat pump brand is ON (ventilation, heating or cooling), it turns on the air curtain ventilation.

The customer can choose a different speed for each of the following conditions:

- Heating/Ventilation mode and door open.
- Heating/Ventilation mode and door closed.
- Cool/Ventilation mode and door open.
- Cool/Ventilation mode and door closed.

In each of these conditions, the desired speed can be programmed by pressing the button.

When it starts cooling mode, it limits the maximum speed if the cooling signal is connected to terminals “+” and “R”.

If the outdoor unit starts defrost, the curtain will stop or go to the minimum speed according to switch 7.

External ON/OFF (“1”, “2”): When the control of the heat pump turns on in any mode (ventilation, heating or cooling), the air curtain also turns on by this contact.

In case of not turning on the ventilation when the heat pump starts to run, the external unit could be damaged. Red LED in OFF indicates that the curtain and the heat pump are in OFF. When the heat pump turns on, the red LED turns OFF and a green or orange LED turns on indicating the speed.

Door Contact (“+”, “T”): If optional door contact is installed, it permits to choose a speed when the door is open and other when the door is closed.

Air curtain changes door open speed (orange LED) to the door closed speed (green LED) after a delay time, configurable according to switches “5” and “6”.

It's possible to use all kinds of sensors (movement sensors, infrared, etc).

Programming by speed button:

- With open door, the user can set the fan speed when the air curtain works with open door.
- With closed door the user can select the fan speed when the air curtain works with closed door.

By default, the first time that the unit is switched ON, the speed with door open will be V5, while when the door is closed it will be V2. The user will be able to change that setting afterwards.

If door contact is not installed, it will always work as open door if switch 2 is in OFF.

The door state is indicated by 2 green LED.

Cool Signal (“+”, “R”): Only for air curtains with cooling mode. When it works in cool (signal active) the maximum speed is limited, configurable using the switches “8” and “9”. With Cool Signal active is possible to select one speed with door open and another with closed door different than the selected for when the signal is not active. The aim is that the suction speed should not exceed 2.5 m/s in order to avoid dragging of condensation droplets.

To use this mode, it’s needed to disconnect the terminal “TR” from the air curtain’s PCB. If not, the air curtain will be limited automatically at the 3rd speed.

If the heat pump works in cold mode and this signal is not connected, the air curtain may be damaged (out of warranty) and/or water will fall out.

In curtains with only heating it is not necessary to limit the speed, so it’s not necessary to connect it.

A green LED indicates if cold mode is working.

Defrost Signal (“+”, “F”): For air curtains with cooling mode, to use this function it’s needed to disconnect the terminal “TR” from the air curtain’s PCB. If not, the air curtain will be limited automatically at the 3rd speed. For air curtains with only heating mode, just connect the signal to the DX kit.

When defrost is on, there are 2 modes that can be selected if the defrost signal is connected on the Slave DX kit:

- Air curtain stops. SW7 in OFF.
- Air curtain works at minimum speed. SW7 in ON.

To minimize the effects of defrost, it is possible to:

- Use units that does not defrost against internal unit, continuous heating systems or similar.
- Use 2 external units in one curtain.
- Use electrical resistors to help.

If one of these systems is used, it is preferable not to reduce the ventilation speed in order to keep the barrier effect. In these cases, don’t connect the defrost signal.

There is a blue LED that indicated when the Defrost is active.

DIP programming (Slave DX)

Inside the control box there are some switches (by default all in OFF) numbered from 1 to 9 that allows:

1: Contact inverter ON/OFF (“1”, “2”).

- Switch “1” in OFF: Closed Contact = Air Curtain ON, Open Contact = Air Curtain OFF.
- Switch “1” in ON: Closed Contact = Air Curtain OFF, Open Contact = Air Curtain ON.

2: Door contact inverter (“+”, “T”).

- Switch “2” in OFF: Closed Contact = Door Closed, Open Contact = Door Open.
- Switch “2” in ON: Closed Contact = Door Open, Open Contact = Closed Door.

3: Cool singal contact inverter (“+”, “R”).

- Switch “3” in OFF: Closed Contact = Cool ON, Open Contact = Cool OFF.
- Switch “3” in ON: Closed Contact = Cool OFF, Open Contact = Cool ON.

4: Defrost contact inverter (“+”, “F”).

- Switch “4” in OFF: Closed Contact = Defrost ON, Open Contact = Defrost OFF.
- Switch “4” in ON: Closed Contact = Defrost OFF, Open Contact = Defrost ON.

5 y 6: the combination of these two switches makes possible to modify the delay time from the moment the door closes until the equipment operates with closed door speed settings.

Switch 5	Switch 6	Delay time
Off	Off	0 sec
On	Off	10 sec
Off	On	60 sec
On	On	120 sec

7: Defrost:

Switch "7"	Speed during Defrost
Off	V0
On	V1

8 y 9: Maximum speed with Cool in ON (by default V3 OFF-OFF). It's the maximum working speed when the air curtain is in cool mode.

Switch "8"	Switch "9"	Maximum speed in Cool mode
On	Off	V1
On	On	V2
Off	Off	V3
Off	On	V4

Strips

Regulator serigraphy:

("1", "2") External ON/OFF

("+", "T") Door Contact

("+", "R") Cool

("+", "F") Defrost

Pipes installation and refrigerant charge

Consult the Mitsubishi Electric's manual.

In reference to the air curtain installation, the refrigerant volumes and the exchanger connections are as following:



For 1-1 installations:

Reference	Exchanger volume [l]	Exchanger connections Gas-Liquid
ECM 1000 DX8-ME	1,8	5/8" – 3/8"
ECM 1500 DX11-ME	2,2	5/8" – 3/8"
ECM 1500 DX13-ME	3	5/8" – 3/8"
ECM 2000 DX16-ME	3,1	5/8" – 3/8"
ECM 2500 DX22-ME	3,9	1"1/8 – 3/8"
ECM 2500 DX24-ME	5,3	1"1/8 – 3/8"
ECM 3000 DX26-ME	4,8	1"1/8 – 1/2"
ECG 1000 DX10-ME	1,8	5/8" – 3/8"
ECG 1500 DX14-ME	2,2	5/8" – 3/8"
ECG 2000 DX22-ME	3,1	5/8" – 3/8"
ECG 2000 DX24-ME	4,1	1"1/8 – 3/8"
ECG 2500 DX27-ME	5,3	7/8" – 3/8"
ECG 3000 DX27-ME	4,8	1"1/8 – 1/2"

For VRF installations:

Reference	Exchanger volume [l]	Exchanger connections Gas-Liquid
ECM 1500 VRF12-ME	1,8	5/8" – 3/8"
ECM 1500 VRF16-ME	3	5/8" – 3/8"
ECM 2000 VRF19-ME	4,1	1"1/8 – 3/8"
ECM 2000 VRF21-ME	4,1	1"1/8 – 3/8"
ECM 2500 VRF24-ME	5,3	1"1/8 – 1/2"
ECM 2500 VRF26-ME	5,3	1"1/8 – 1/2"
ECM 3000 VRF30-ME	4,8	1"1/8 – 1/2"
ECG 1000 VRF10-ME	1,8	5/8" – 3/8"
ECG 1500 VRF13-ME	2,2	5/8" – 3/8"
ECG 1500 VRF15-ME	3,0	5/8" – 3/8"
ECG 2000 VRF20-ME	3,1	1"1/8 – 3/8"
ECG 2000 VRF24-ME	4,1	1"1/8 – 1/2"
ECG 2500 VRF25-ME	3,9	1"1/8 – 1/2"
ECG 2500 VRF29-ME	5,3	1"1/8 – 1/2"
ECG 3000 VRF29-ME	4,8	1"1/8 – 1/2"

Temperature sensors in the air curtain

	<p>If some welding is made in the pipes of the air curtains coil, the sensors can be damaged, causing operating errors. If some welding must be done, avoid that the heat reaches the air curtain sensors.</p>
	<p>All consequential damages, direct and indirect, due to wrong installation of the air curtain are excluded from the guarantee.</p>

• High pressure (liquid) and middle point sensors. Only for 1:1 Kit PAC-IF013B-E

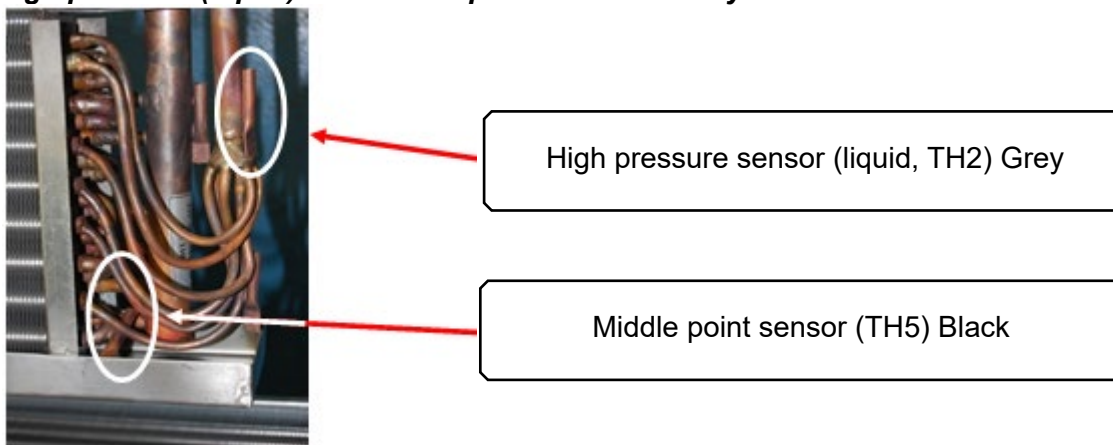

The liquid and middle point sensor will be placed on the supports shown on the previous image.

• High pressure (liquid) and low pressure (gas) sensors. Only for VRF Kit PAC-AHxxxM-J

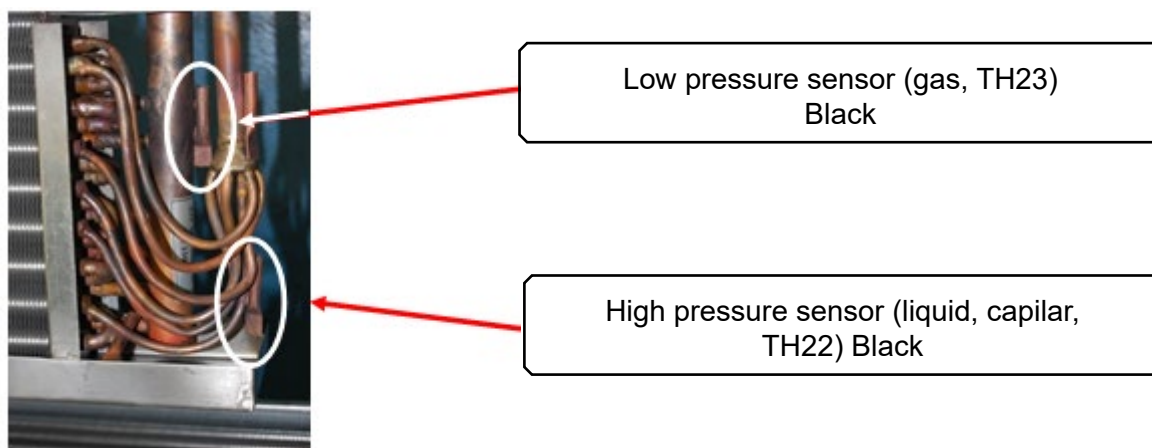

The liquid and gas sensors will be placed on the supports shown on the previous image.

- **Room sensor**

For 1:1 systems (PAC-IF0):

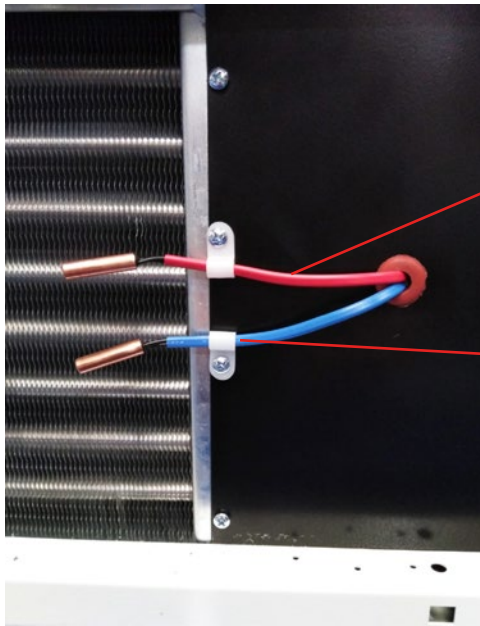

Room Sensor (TH1) Red

Room Sensor (TH11) Blue

For VRF system (PAC-AH):

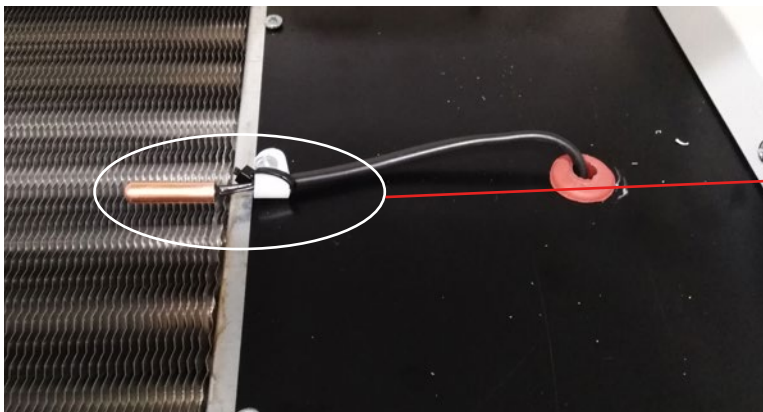

Room Sensor (TH21 y TH24)

In VRF system of only heating, the sensor TH24 is replaced for a resistor placed in the Kit PAC-AH.
In heating/cooling VRF system, the TH21 and TH24 are placed together in the suction of the air curtain (return).

The flange and cable hole are installed in the inlet air curtain zone. If we want to access to the sensor, we should remove the inlet grill (see repairs section of this manual).

Once all sensors are installed, proceed with the insulation to avoid the sensors contact with the air. For the insulation use thermal insulating foam, insulating tape, etc.

Find an example in the following picture of how to insulate the sensors:



AIR CURTAINS WORKING MODE



Air curtains which are not prepared to work in cooling **MUST NEVER** start the cooling mode. In case they started to work in cooling mode, the condensation in the coil could reach the electronic components and cause water droplets through the outlet and the service door of the air curtain, losing all guarantee.

If the air curtain is ONLY HEATING, it cannot be integrated into a centralized control if the mode change cannot be locked.

Airtècnics does not recommend air curtains to work with cool, because the air speed must be limited to try to avoid the dragging condensates. Due to this limitation, the air curtain doesn't perform the air barrier function as it should be.

WIRING DIAGRAMS

This manual complements with the air curtain's wiring diagram:

- Air curtain with heat pump DX 1:1 only heating with Slave DX – AIRDOE99812
- Air curtain with heat pump DX 1:1 heating/cooling with Slave DX – AIRDOE99813
- Air curtain with heat pump DX VRV only heating with Slave DX – AIRDOE99820
- Air curtain with heat pump DX VRV heating/cooling with Slave DX – AIRDOE99821

DATASHEET

WINDBOX M,G DX-ME

HEAT PUMP ENERGY SAVING AIR CURTAINS FOR MITSUBISHI ELECTRIC OUTDOOR UNITS (1:1)

Technical Features



RAL 9016 standard Stainless steel Other colors on request

Range
Up to 4,2 m

Heating types
**Heat Pump
Gas R410**

Casing
**Galvanised Steel
Self-Supporting**

Airflow / Length
**1640 - 5840 m³/h
1m to 3m**

Heating capacity
8 - 27 kW

Grille type
**Micro-perforated with
pre-filter included**

Fans
**Centrifugal
5-speed**

Control
**Slave DX regulator
Consult other options**

Outlet vanes
**Aluminium, airfoil type
Adjustable 0-15° each side**

WINDBOX air curtains range provide equipment suitable for all types of commercial entrances. A compact and robust air curtain from our standard range with a timeless design, ready for visible installation over the door and prepared for multiple false ceiling installation configurations.

In heating, it reduces consumption and CO2 emissions by up to 70%.

Sensors pre-installed in the direct expansion coil. As an option, under request, it can also work in cold mode (refrigeration), with optional condensate water pump.

Efficient EC centrifugal fans with low consumption, double inlet with external rotor motor and low noise level. Internal pre-filter included.

Plug&Play Slave DX control programmable according to the door status. Consult other regulation options (slave or master).

Ready to connect to Mitsubishi Electric Inverter outdoor heat pump unit (R32/R410A) and expansion valve not included, the customer should purchase it.

AIR CURTAIN SPECIFICATIONS

Model	Airflow m³/h	Ventilation power	Ventilation current	Outdoor unit	Outdoor unit	Pipes gas-liquid	Noise level (5 m)	Weight kg
		230V-50/60Hz kW	230V-50/60Hz A	230Vx1	400Vx3	inch	dB(A)	
ECM 1000 DX8-ME	1640	0,142	1,24	PUZ-ZM71VHA	-	5/8" - 3/8"	56	35
ECM 1500 DX11-ME	2460	0,213	1,86	PUZ-ZM100VKA	PUZ-ZM100YKA	5/8" - 3/8"	57	53
ECM 1500 DX13-ME	2460	0,213	1,86	PUZ-ZM125VKA	PUZ-ZM125YKA	5/8" - 3/8"	57	53
ECM 2000 DX16-ME	3280	0,284	2,48	PUZ-ZM140VKA	PUZ-ZM140YKA	5/8" - 3/8"	58	69
ECM 2500 DX22-ME	4100	0,355	3,10	-	PUZ-ZM200YKA	1"1/8 - 3/8"	59	86
ECM 2500 DX24-ME	4100	0,355	3,10	-	PUZ-ZM250YKA	1"1/8 - 3/8"	59	86
ECM 3000 DX26-ME	4920	0,426	3,72	-	PUZ-ZM250YKA	1"1/8 - 1/2"	60	103
ECG 1000 DX10-ME	2190	0,213	1,86	PUZ-ZM100VKA	PUZ-ZM100YKA	5/8" - 3/8"	61	50
ECG 1500 DX14-ME	2920	0,284	2,48	PUZ-ZM125VKA	PUZ-ZM125YKA	5/8" - 3/8"	62	59
ECG 2000 DX22-ME	4380	0,426	3,72	-	PUZ-ZM200YKA	5/8" - 3/8"	63	92
ECG 2000 DX24-ME	4380	0,426	3,72	-	PUZ-ZM250YKA	1"1/8 - 3/8"	63	92
ECG 2500 DX27-ME	5110	0,497	4,34	-	PUZ-ZM250YKA	1"1/8 - 1/2"	64	96
ECG 3000 DX27-ME	5840	0,568	5,96	-	PUZ-ZM250YKA	1"1/8 - 1/2"	65	109

OUTDOOR UNIT SPECIFICATIONS

Mitsubishi Inverter outdoor unit model	Heating capacity	COP or SCOP	Cooling capacity	EER or SEER	Power supply	Pipes gas-liquid	Pipes maximum length	Pipes maximum height
	kW		kW			inch	m	m
PUZ-ZM71VHA	8	4,30	7,1	4,39	230Vx1	5/8" - 3/8"	50	30
PUZ-ZM100VKA	11,2	4,53	10	4,68	230Vx1	5/8" - 3/8"	100	30
PUZ-ZM100YKA	11,2	4,53	10	4,68	400Vx3	5/8" - 3/8"	100	30
PUZ-ZM125VKA	14	3,86	12,5	3,95	230Vx1	5/8" - 3/8"	100	30
PUZ-ZM125YKA	14	3,86	12,5	3,95	400Vx3	5/8" - 3/8"	100	30
PUZ-ZM140VKA	16	3,76	14	3,71	230Vx1	5/8" - 3/8"	100	30
PUZ-ZM140YKA	16	3,76	14	3,71	400Vx3	5/8" - 3/8"	100	30
PUZ-ZM200YKA	22,4	3,77	20	3,65	400Vx3	1"1/8 - 3/8"	70	30
PUZ-ZM250YKA	27	3,47	25	3,22	400Vx3	1"1/8 - 1/2"	70	30

When adverse weather conditions, the outdoor unit capacity can decrease. It is recommendable to oversize the units.

WINDBOX M,G VRF-ME | HEAT PUMP ENERGY SAVING AIR CURTAINS FOR MITSUBISHI ELECTRIC OUTDOOR UNITS (VRF)

Technical Features



RAL 9016 standard  Stainless steel  Other colors on request 



Range
Up to 4,2 m

Heating types
Heat Pump
Gas R410

Casing
Galvanised Steel
Self-Supporting



Airflow / Length
2190 - 5840 m³/h
1m to 3m

Heating capacity
10 - 29 kW

Grille type
Micro-perforated with
pre-filter included

Fans
Centrifugal
5-speed

Control
Slave DX regulator
Consult other options

Outlet vanes
Aluminium, airfoil type
Adjustable 0-15° each side

WINDBOX air curtains range provide equipment suitable for all types of commercial entrances. A compact and robust air curtain from our standard range with a timeless design, ready for visible installation over the door and prepared for multiple false ceiling installation configurations.

In heating, it reduces consumption and CO2 emissions by up to 70%.

Sensors pre-installed in the direct expansion coil. As an option, under request, it can also work in cold mode (refrigeration), with optional condensate water pump.

Efficient EC centrifugal fans with low consumption, double inlet with external rotor motor and low noise level. Internal pre-filter included.

Plug&Play Slave DX control programmable according to the door status. Consult other regulation options (slave or master).

Ready to connect to Mitsubishi Electric VRF outdoor heat pump unit (R32/R410A) and expansion valve not included, the customer should purchase it.

AIR CURTAIN SPECIFICATIONS

Model	Airflow	Ventilation power	Ventilation current	Expansion valve	Pipes gas-liquid	Noise level (5 m)	Weight
	m ³ /h	230V-50/60Hz kW	230V-50/60Hz A		inch	dB(A)	
ECM 1500 VRF12-ME	2460	0,213	1,86	PAC-AH125M-J	5/8" - 3/8"	57	53
ECM 2000 VRF16-ME	3280	0,284	2,48	PAC-AH125M-J	5/8" - 3/8"	58	69
ECM 2000 VRF19-ME	3280	0,284	2,48	PAC-AH250M-J	1"1/8 - 3/8"	58	69
ECM 2500 VRF21-ME	4100	0,355	3,10	PAC-AH250M-J	1"1/8 - 3/8"	59	86
ECM 2500 VRF24-ME	4100	0,355	3,10	PAC-AH250M-J	1"1/8 - 1/2"	59	86
ECM 3000 VRF26-ME	4920	0,426	3,72	PAC-AH250M-J	1"1/8 - 1/2"	60	103
ECM 3000 VRF30-ME	4920	0,426	3,72	PAC-AH250M-J	1"1/8 - 1/2"	60	103
ECG 1000 VRF10-ME	2190	0,213	1,86	PAC-AH125M-J	5/8" - 3/8"	61	50
ECG 1500 VRF13-ME	2920	0,284	2,48	PAC-AH125M-J	5/8" - 3/8"	62	59
ECG 1500 VRF15-ME	2920	0,284	2,48	PAC-AH125M-J	5/8" - 3/8"	62	59
ECG 2000 VRF20-ME	4380	0,426	3,72	PAC-AH250M-J	1"1/8 - 3/8"	63	92
ECG 2000 VRF24-ME	4380	0,426	3,72	PAC-AH250M-J	1"1/8 - 1/2"	63	92
ECG 2500 VRF25-ME	5110	0,497	4,34	PAC-AH250M-J	1"1/8 - 1/2"	64	96
ECG 2500 VRF29-ME	5110	0,497	4,34	PAC-AH250M-J	1"1/8 - 1/2"	64	96
ECG 3000 VRF29-ME	5840	0,568	4,96	PAC-AH250M-J	1"1/8 - 1/2"	65	109

VRF-compatible models are as follows:

- City Multi - Y Series (Heat Pump)
- City Multi - R2 Series (Heat Recovery)



Selection program

When adverse weather conditions, the outdoor unit capacity can decrease. It is recommendable to oversize the units.

Dimensions

Horizontal free hanging Installation

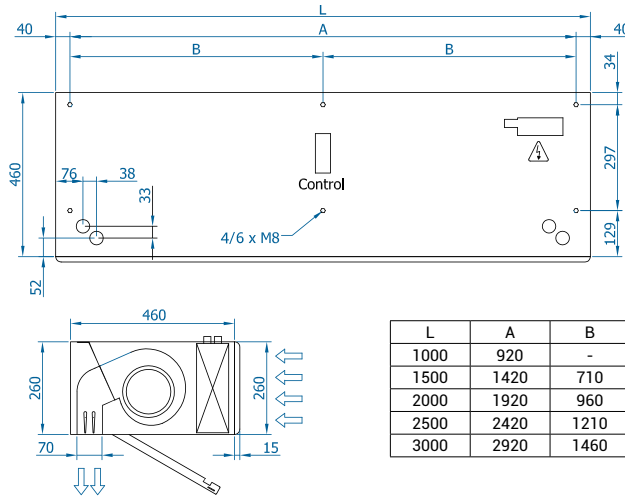

Inside ceiling surface mounting

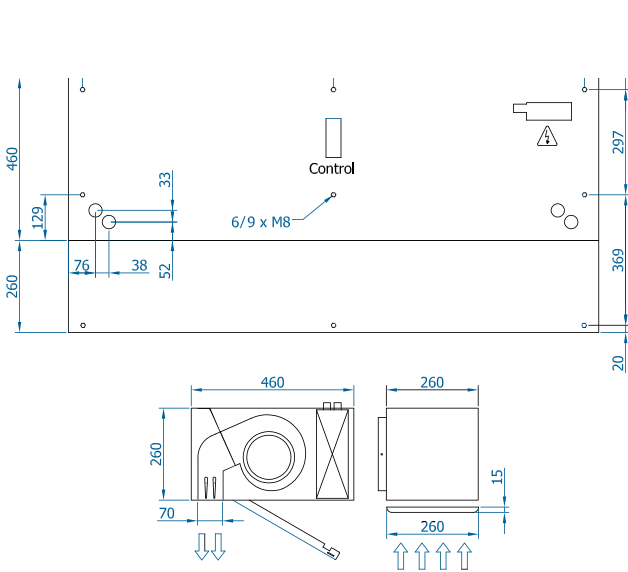

False ceiling invisible mounting

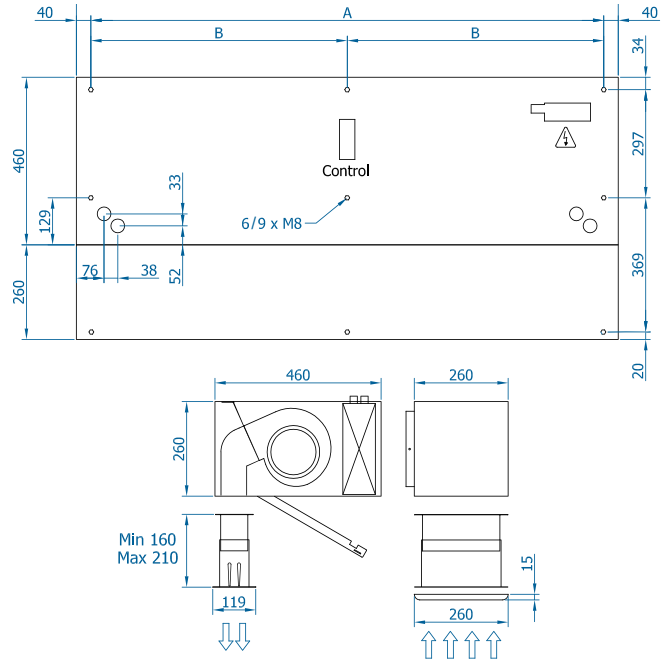

CAD drawings, BIM files, installation manuals and other documents



WINDBOX M,G DX/VRF-ME | HEAT PUMP ENERGY SAVING AIR CURTAINS FOR MITSUBISHI ELECTRIC OUTDOOR UNITS (1:1 - VRF)

Installation configurations

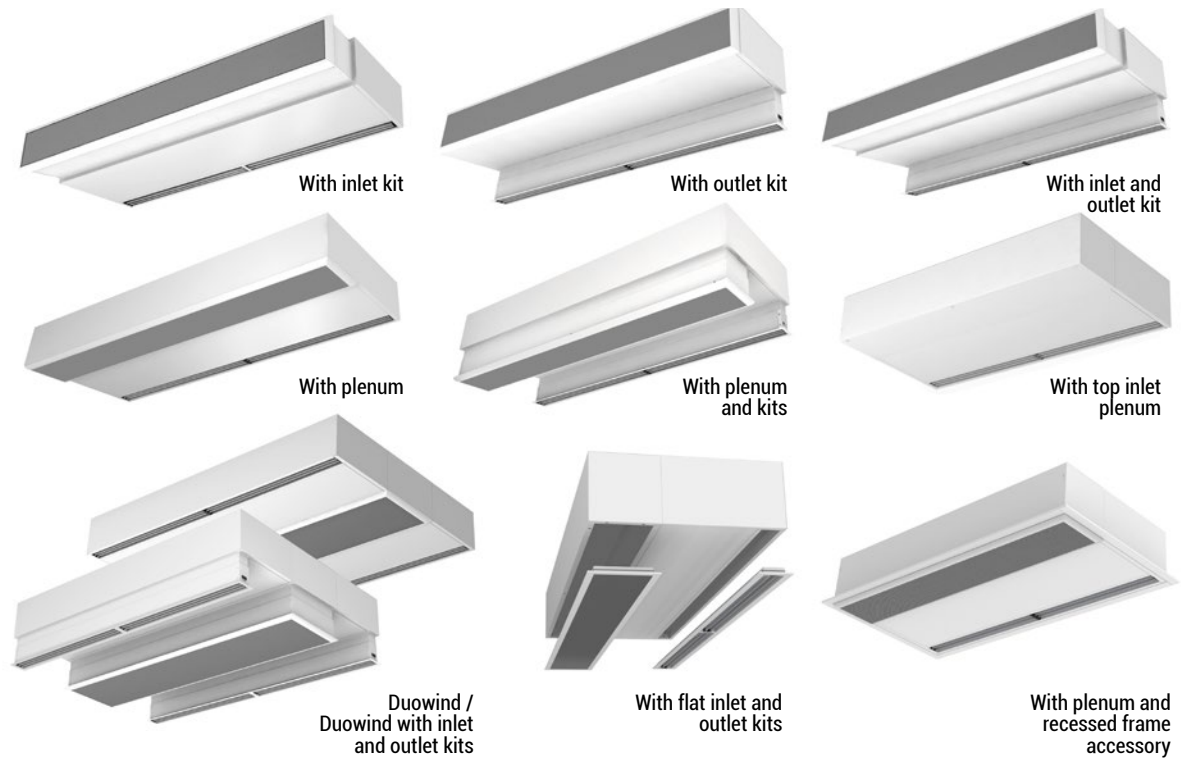

DAM DX/ VRF-ME | HEAT PUMP ENERGY SAVING AIR CURTAINS FOR MITSUBISHI ELECTRIC OUTDOOR UNITS (1:1 - VRF)

Dimensions

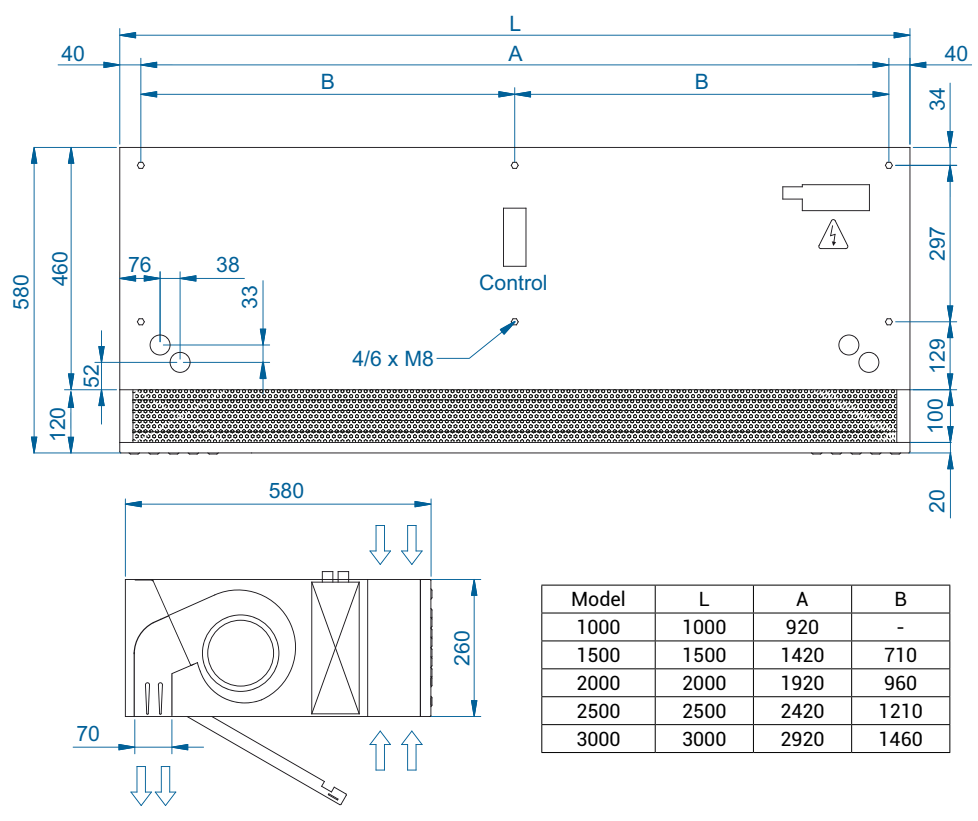

CAD drawings, BIM files, installation manuals and other documents



RECESSED WINDBOX DX/VRF-ME HEAT PUMP ENERGY SAVING AIR CURTAINS FOR MITSUBISHI ELECTRIC OUTDOOR UNITS (1:1 - VRF)

Dimensions

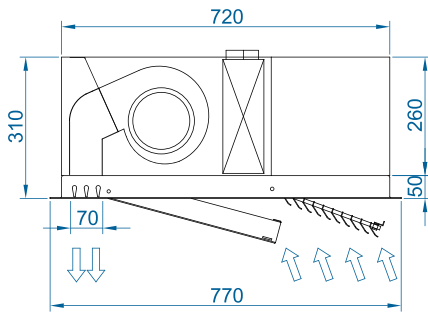
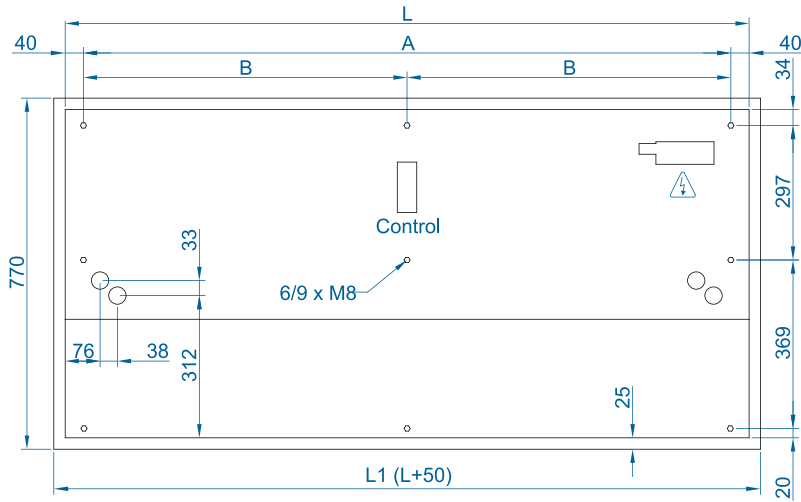

Model	L	L1	A	B
1000	1000	1050	920	-
1500	1500	1550	1420	710
2000	2000	2050	1920	960
2500	2500	2550	2420	1210

CAD drawings, BIM files, installation manuals and other documents



RECESSED DAM DX/VRF-ME HEAT PUMP ENERGY SAVING AIR CURTAINS FOR MITSUBISHI ELECTRIC OUTDOOR UNITS (1:1 - VRF)

Dimensions

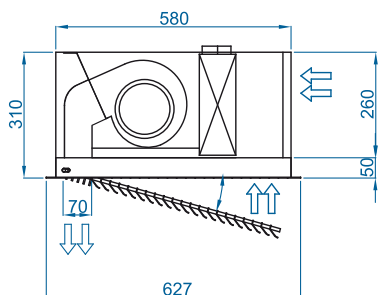
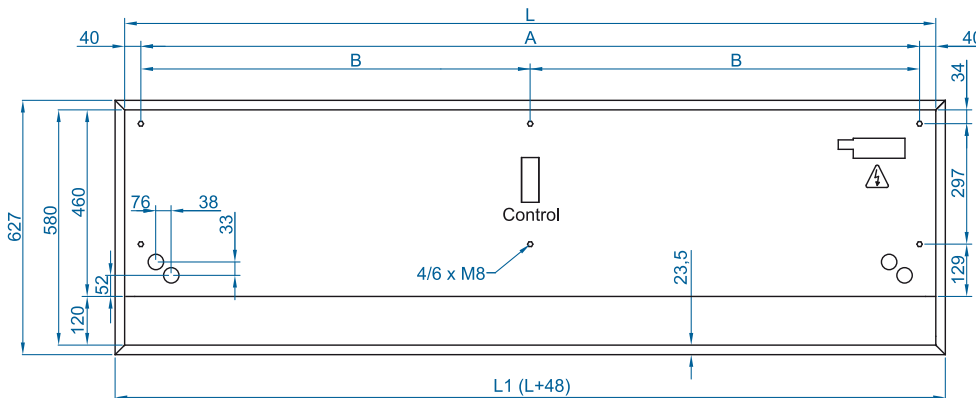

Model	L	L1	A	B
1000	1000	1048	920	-
1500	1500	1548	1420	710
2000	2000	2048	1920	960
2500	2500	2548	2420	1210

CAD drawings, BIM files, installation manuals and other documents



INVISAIR DX/VRF-ME | HEAT PUMP ENERGY SAVING AIR CURTAINS FOR MITSUBISHI ELECTRIC OUTDOOR UNITS (1:1 - VRF)

Dimensions

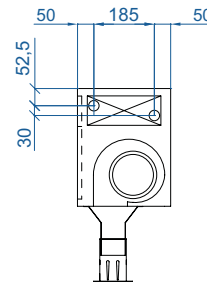
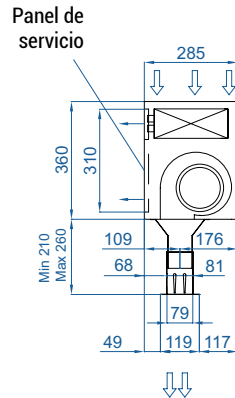
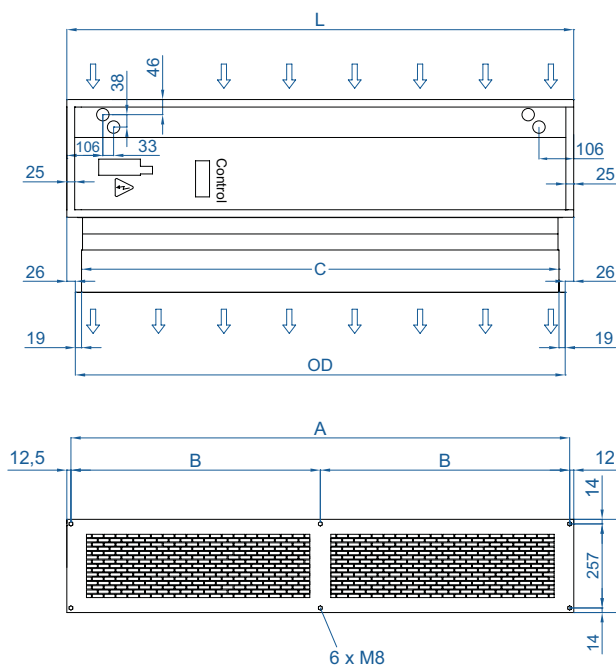

Model	L	A	B
1000	1050	1025	-
1500	1550	1525	762
2000	2050	2030	1015
2500	2550	2530	1265
3000	3050	2930	1465

CAD drawings, BIM files, installation manuals and other documents



SMART DX/VRF-ME | HEAT PUMP ENERGY SAVING AIR CURTAINS FOR MITSUBISHI ELECTRIC OUTDOOR UNITS (1:1 - VRF)

Dimensions

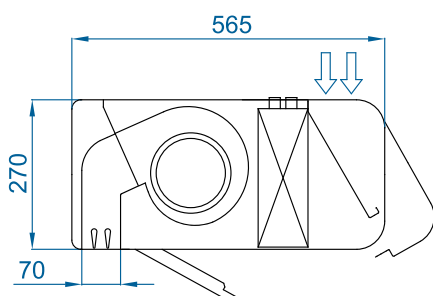
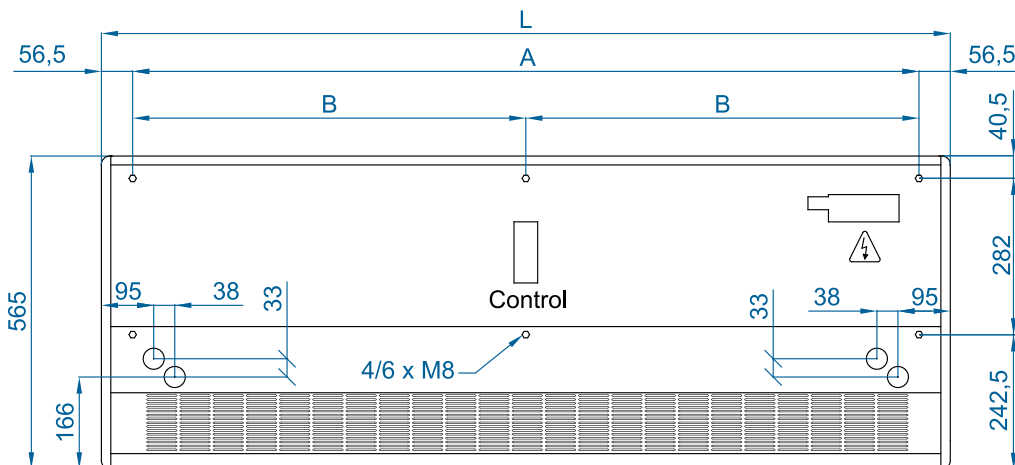

Model	L	A	B
1000	1034	920	-
1500	1534	1420	710
2000	2034	1920	960
2500	2534	2420	1210
3000	3034	2920	1460

CAD drawings, BIM files, installation manuals and other documents



Dimensions

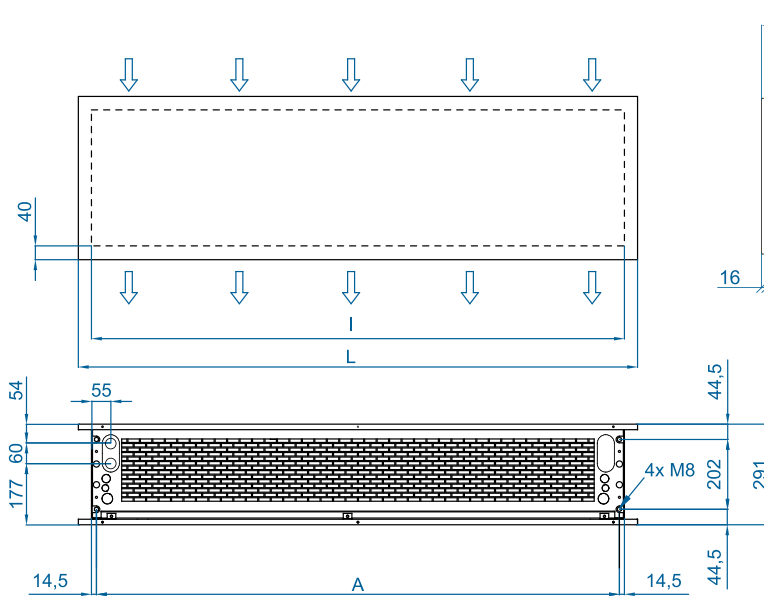

Model	E	I	A
1000	1220	1140	1115
1500	1620	1544	1515
2000	2120	2044	2015
2500	2620	2544	2515

CAD drawings, BIM files, installation manuals and other documents



Finishings



Vertical installation



Dimensions

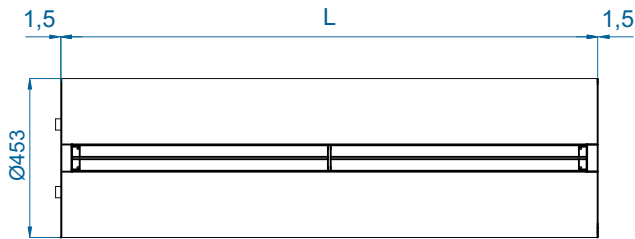

Model	L
1000	1025
1500	1525
2000	2030
2500	2530
3000	2980

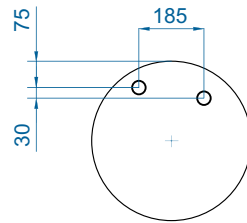
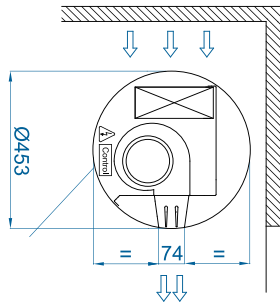

CAD drawings, BIM files, installation manuals and other documents



Configurations and supports



Ceiling fixation through threaded rods



Wall/ceiling fixation through arms



Wall/ceiling fixation through angle supports



Wall fixation through lateral arms



Floor fixation (goalpost)

Dimensions

Standard: Installation above the door

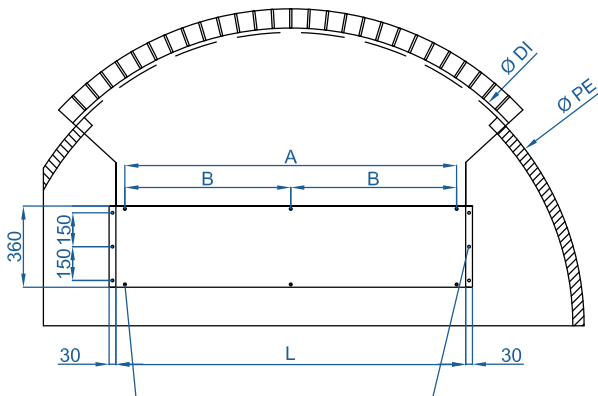
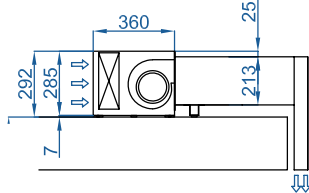

Model	L
1000	1050
1500	1550
2000	2055
2500	2555

Inverted: False ceiling installation

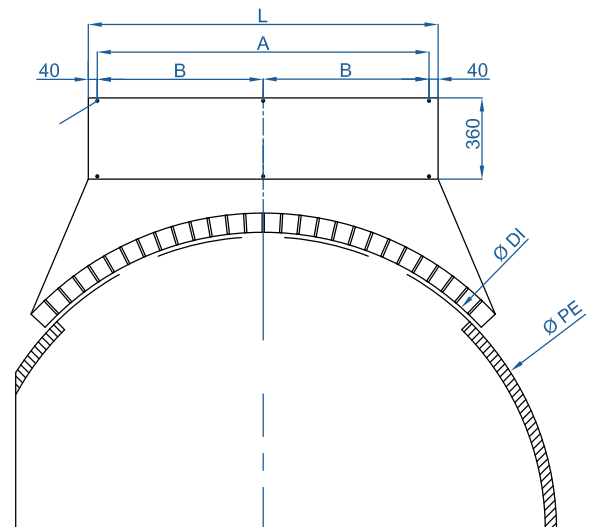
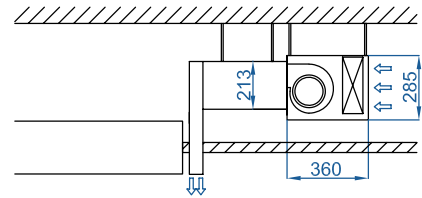
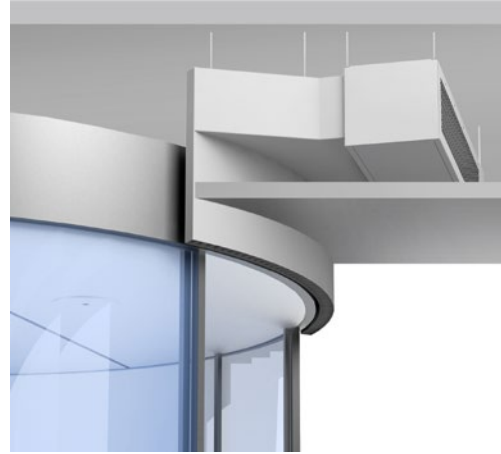





ØDI	Inside outlet diameter
ØPE	External door diameter

CAD drawings, BIM files, installation manuals and other documents



MAINTENANCE INSTRUCTIONS

	For safety, before cleaning, stop the air curtain through the control and wait 10 minutes before disconnect the device from the current.
 	Do not open the service door (risk of electric shock and entrapment in the fans). Repairs must be carried out exclusively by authorized personnel.
	The inside of the device must not be cleaned with water or steam.
	For manipulation safety, being it assembling, transport or maintenance it's a must to wear the correct individual protection equipment recommended. Those being gloves, insulating shoes, goggles and helmet.

Indicative periodicity of maintenance

N° Action	Action	Frequency
1	Filter cleaning	Bimonthly (recommended monthly)
2	Suction grille cleaning	Bimonthly (recommended monthly)
3	Exterior cleaning	Semiannual (recommended quarterly)
4	Interior cleaning	Semiannual (recommended quarterly)
5	Internal components visual inspection	Biannual (recommended annual)
6	Consumption and auditory control checking	Biannual (recommended annual)

Filter cleaning

The particle filter of the air curtain protects the coil from dirt and foreign elements that may clog it, causing a high efficiency performance reduction. On the following pages you will find the instructions for removing the filter for maintenance according to the standard air curtain model (Windbox) or Zen model. *For other models a separate instruction is attached.*

Windbox model includes a micro-perforated grille which has pre-filter functions, additional to the filter installed before the DX coil. The suction grille must be removed before cleaning the filter. These can be cleaned using a Hoover with a brush in order to not damage the filter. It is advisable to carry out this maintenance periodically to achieve the best efficiency of the equipment.

STANDARD AIR CURTAIN - Filter Installation

1 - Place and fasten the filters to the air curtain, using clamps:



Use
safety gloves

In the case of air curtains without plenum, the filters come already pre-installed inside the air curtain.

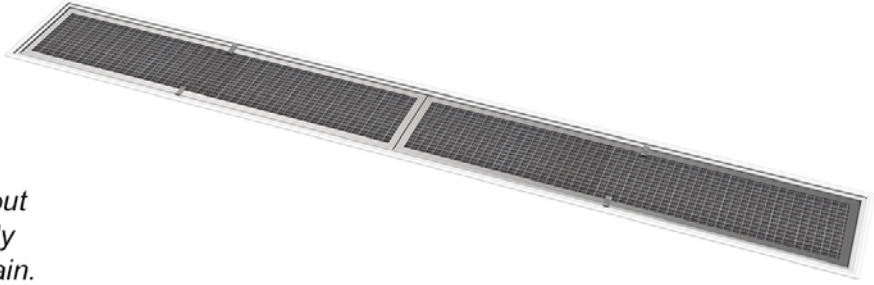

The clamps should be placed asymmetrically in the middle to make it easier to insert and remove the filter.

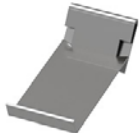
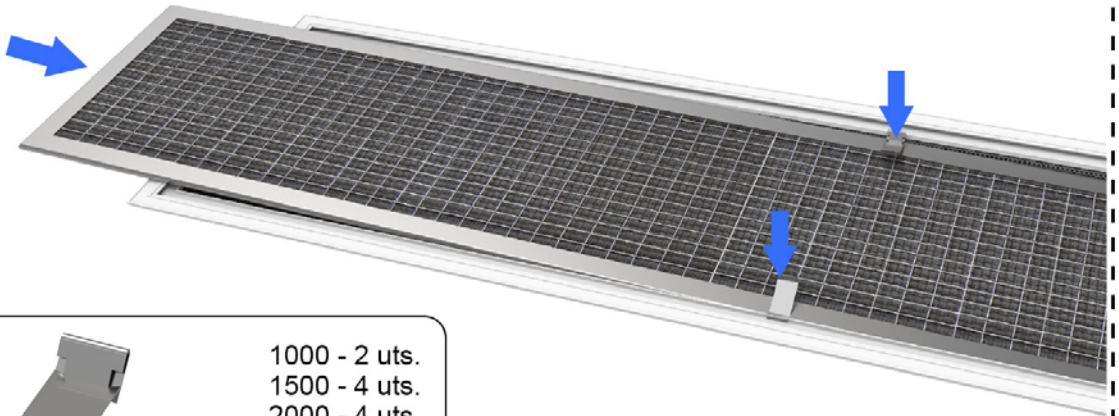

Clamp

1000 - 2 uts.
1500 - 4 uts.
2000 - 4 uts.
2500 - 6 uts.
3000 - 6 uts.

2 - Inlet grille fixing, inserting their pivots inside the air curtain clip holes.

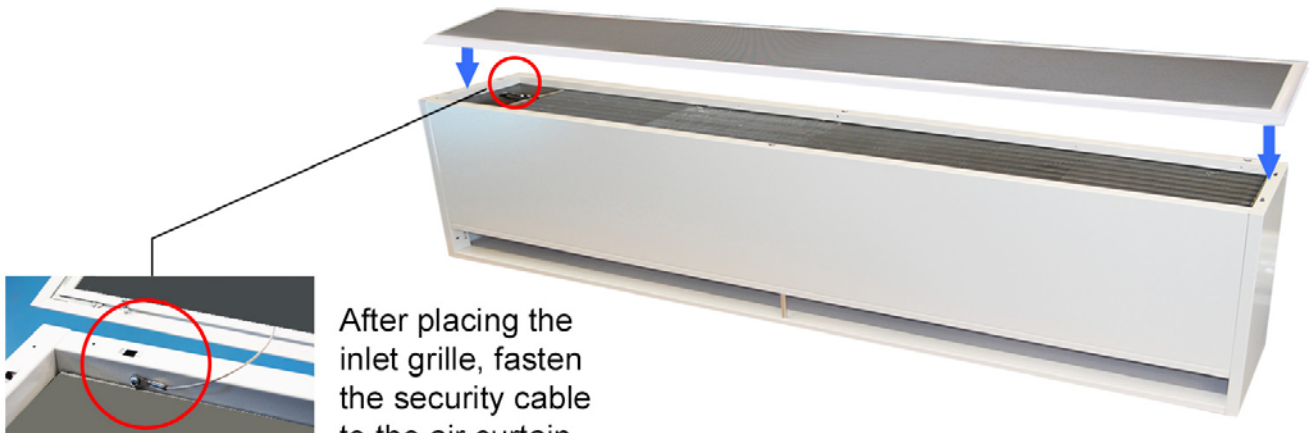

After placing the inlet grille, fasten the security cable to the air curtain

AIR CURTAIN WITH INLET PLENUM - Plenum and filter assembly process

1 - Assemble the plenum in the air curtain, using the indicated holes:



Use safety gloves



	1000 - 8 pcs.
	1500 - 10 pcs.
	2000 - 13 pcs.
DIN 7504N	2500 - 13 pcs.
Philips 3,5 x 9,5	3000 - 14 pcs.

2 - Place and fasten the filters to the air curtain, using clamps:



(Same clamps assembly sequence than "Standad Air Curtain")

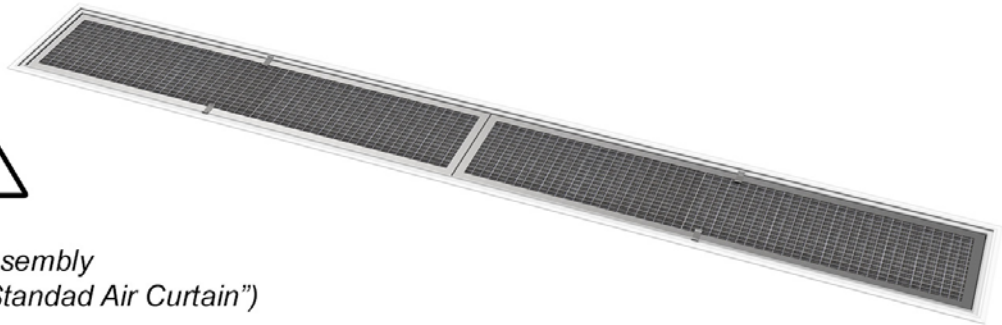

3 - Inlet grille fixing, inserting their pivots inside the air curtain clip holes.



After placing the inlet grille, fasten the security cable to the air curtain



In case of the **Zen** air curtain model, the filter is accessible from the top part of the curtain, through the suction area. To carry out the maintenance, it is not necessary to remove the screws that fix the guides that hold the filters. Follow the instructions below to disassemble the filters easily. It is advisable to carry out this maintenance periodically to achieve the best efficiency of the equipment.

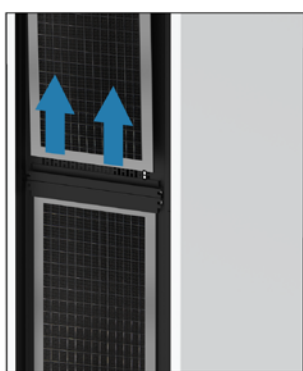
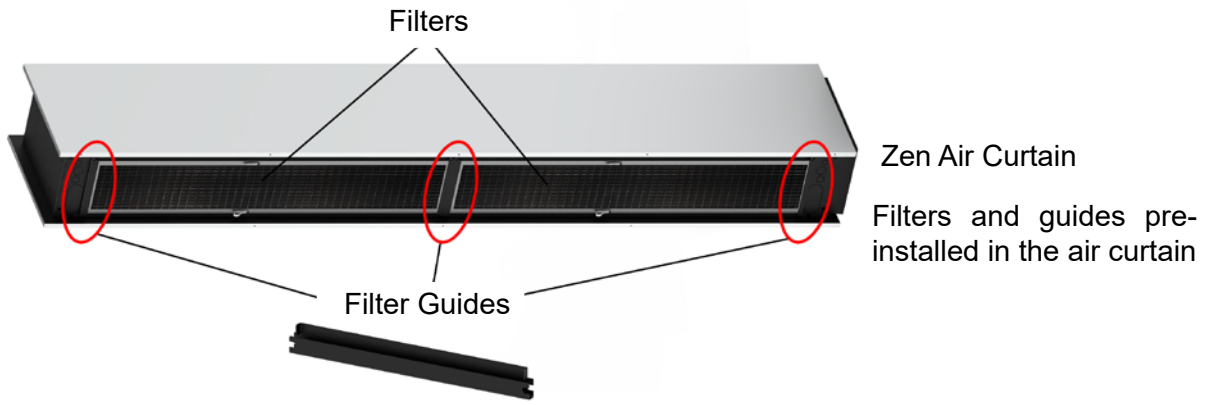

The filters can be removed without disassembling the guides. Simply push it to the side and lift it out of the guide. Clean the filter gently with a Hoover. Do the reverse process to put the filters back in place.

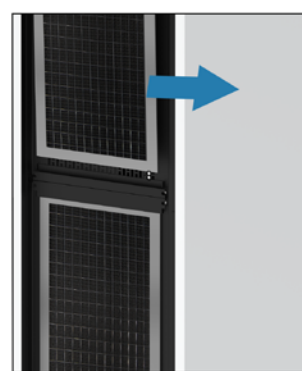

Suction grille cleaning

The suction grille prevents the entry of objects into the internal elements. It is highly recommended to check that the suction grille is free of any object that could prevent air from entering (plastic bags, paper, etc.). If the air curtain has a microperforated suction grille (it works as a prefilter and prevents dust from entering the internal elements), use a vacuum cleaner with a brush so as not to damage the microperforated grille. It is advisable to do it frequently (depending on the dirt generated) since performance is considerably reduced.

It is recommended to clean the suction grille monthly. In addition, it is important to make sure that the air curtain is off, otherwise the mixture between the dust and a damp cloth would form a paste of dirt that could damage the fan rotor when it sucks in the air or clog the water battery.

An annual cleaning of the discharge area must be carried out.

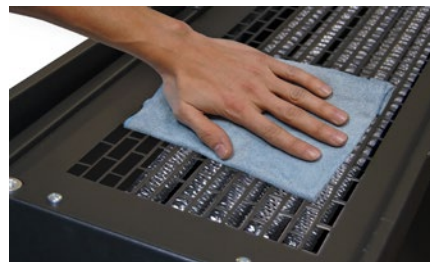

Exterior cleaning

Wipe the entire outer surface of the air curtain (except the suction grille) with a damp cloth to trap dust particles. In addition to the damp cloth, neutral soaps that do not contain acids or are caustic can be used.

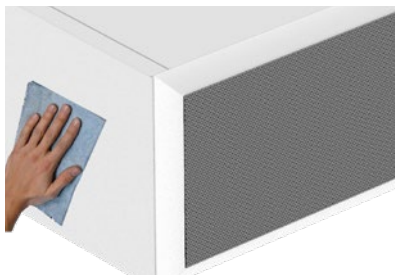

Interior cleaning

It is recommended to clean the inside of the unit with a vacuum cleaner at least once every 2 years. (*) It is recommended to clean the inside of the equipment frequently with the help of a vacuum cleaner, especially before the arrival of winter. (*)

(*) These periods are indicative depending on the conditions of each installation. In places with a high number of suspended particles, it is desirable to increase the frequency of interior cleaning.



Internal components visual inspection

Check that the regulation board has not suffered any damage and it is securely fastened to the equipment frame. Make sure that the board and internal wiring connectors are still well connected. Check that the motors do not move from their mountings and check that the turbines have no impediments to rotate freely (turn it by hand, first turn off the device).





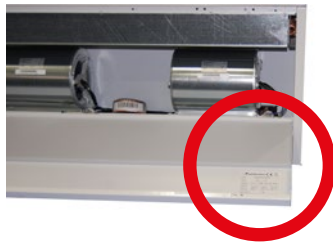

Consumption and auditory control checking

Write down the consumption value of the fans that appears on the product label (located on the inside of the service door). Close the door, give power supply to the air curtain and with the help of an ammeter, check that the electrical consumption of the air curtain at maximum speed is between 110% and 85% of the value indicated on the label. Check that all fans blow air. Keep the air curtain at full speed for a few minutes and listen for abnormal noises from the air curtain.



REPAIRS AND REPLACEMENTS

Assembly and electrical connection must be carried out exclusively by specialized professionals and in compliance with these instructions.
Before carrying out any repair, it is necessary to:

	<ul style="list-style-type: none"> • Notify staff and indicate that work is being done. • Disconnect the current and protect the circuit breaker.
	<ul style="list-style-type: none"> • Be sure there is no voltage in the unit.
	<ul style="list-style-type: none"> • Be sure the fans have stopped. • Use only original spare parts.
	<p>For manipulation safety, being it assembling, transport or maintenance duties it's a must to wear the correct individual protection equipment recommended. Those being gloves, insulating shoes, goggles and helmet.</p>



CODE	COMPONENT	COMPONENT REFERENCE	CURTAIN MODEL
AIRSEC99210	EC Centrifugal Fan	GDSG9 146X188R N46-A0 EC	ECM - ECG: All models
AIRSEC99299	Repair kit EC 5-speed DX tropicalised plate	PSE-05V-EC-T	ECM - ECG: All models
TERCCO33185	SLAVE DX 5-speed curtain controller for heat pump curtains	CS-5DX-NE	ECM - ECG: All models

Service door opening

Windbox: To open the service door, follow these steps:



1.- Insert a flat screwdriver between the casing and the grille and push the grill out. The grille is closed by pressure through pivots. It has a safety cable to avoid accidental falls.



2.- **OPTIONAL:** Remove the security screw of the service door.

3.- Insert a screwdriver and press close to the pivots to open the service door.

In case of an air curtain with **plenum or inlet/outlet kits**, the lever must be done from the side of the door where there is an oblong hole, to make it easier the entrance of a flat screwdriver.



Dam: Follow the same instructions as for the Windbox air curtain with plenum or inlet/outlet kits.

Recessed Windbox: To open the service door in Recessed Windbox models follow the next steps:

1.- With a screwdriver remove the security screws from the service door.

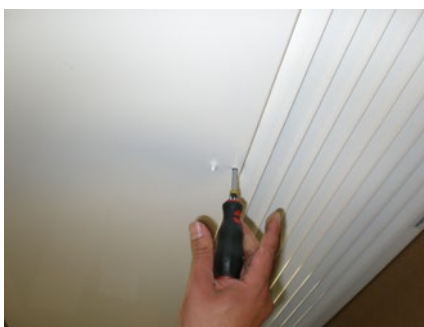

2.- Open the service door with both hands as indicated. The grille is closed by pressure clamps. The door is also closed by pressure through bollard. Both are pivoting. It's possible to open the big door first or open it with the help of the door with grille.

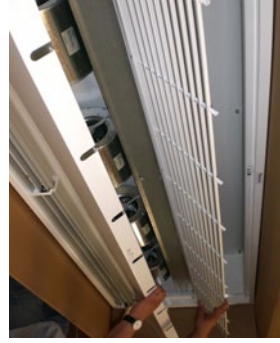

Recessed Dam: Remove the two security screws on both sides of the air curtain and open the suction grille with both hands.



Invisair / Rotowind: To open the service panel and access the insides of the air curtain, remove the screws from the service door and pull to the outside to disengage it from the security screw and finally be able to open the service door with both hands.



Smart: Remove the screws from the service door and open the panel with both hands.



Zen: Remove the security screws from the top part of the air curtain. Open the service door with both hands. If it's necessary, remove the security cables and extract the panel sliding it to the side of the air curtain.

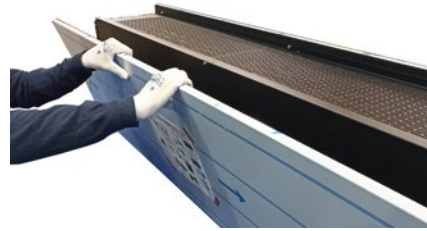

Rund: Remove the screws from the suction grille and open it using both hands.



Remove the screws that attach the battery casing. Remove the screws securing the service panel to the curtain cabinet.



Open the service panel with both hands to have access to the insides of the air curtain.



Fan replacement

Before replacing the fan, inform people that there is work in progress. Stop the air curtain through the controller and disconnect the main power supply. Check the unit has no tension and the fans have stopped. Identify and unplug the cables from the fan. Remove the screws that attach the fan to the structure and assemble the new one following the process in reverse order.

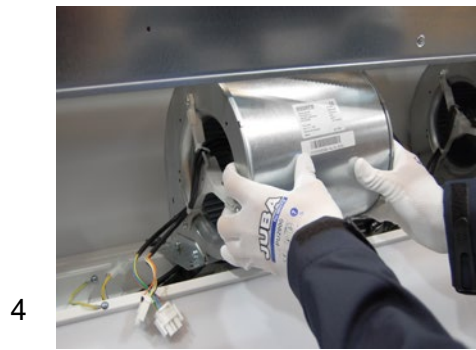
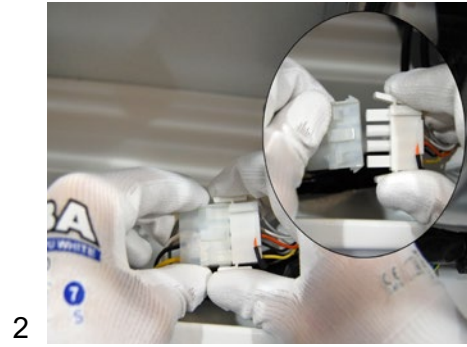

PCB and fuse replacement

Before changing the PCB or the fuse, inform people that there is work in progress. Stop the air curtain through the controller and disconnect the main power supply. Check the unit has no tension and the fans have stopped.

Change the PCB: open the service door and unscrew the PCB from inside the air curtain in order to do the necessary repairs to it.

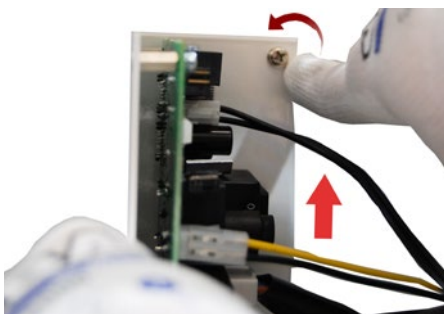

Change the fuse: open the service door and extract the fuse from the PCB by hand or with the help of a screwdriver pressing on the fuse cap and turning it counterclockwise. In some cases, it's recommended to unscrew the PCB to work better.

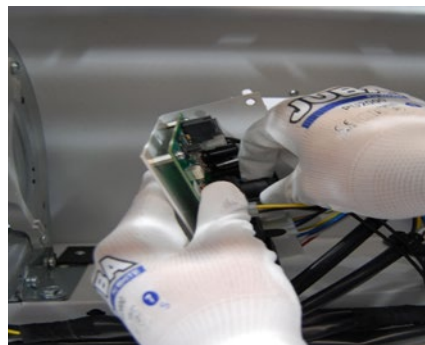

Recommendation: installation with silentblocks

To reduce the sound level and the vibrations of the air curtain, it is recommended to carry out an installation with silentblocks:

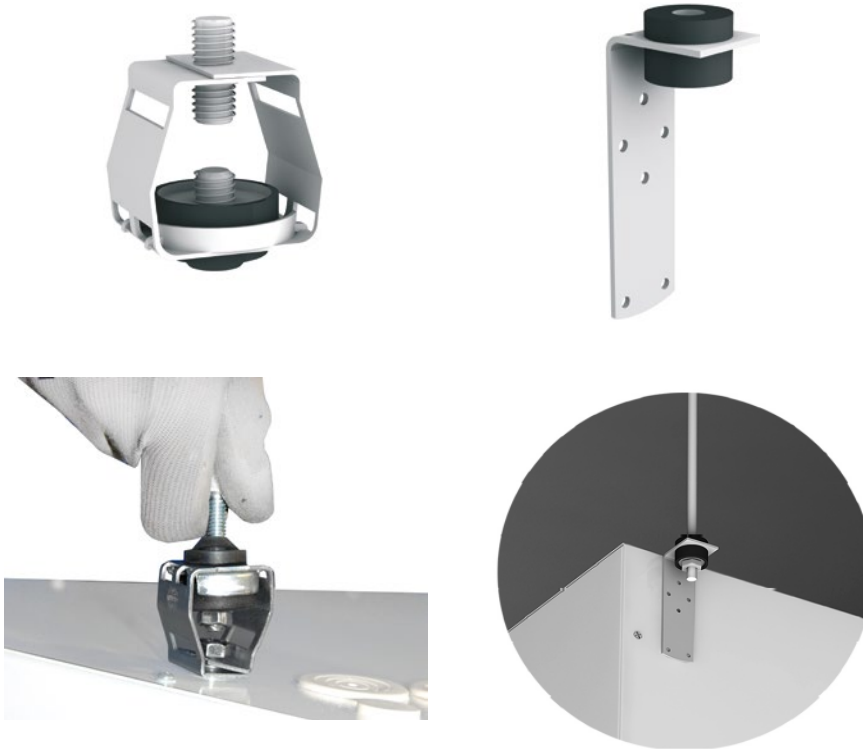

TROUBLESHOOTING

More than 95% of the claims occur **during the start-up** of the equipment and **are due to installation errors**. Reviewing the following points solves more than 90% of the incidents:

A) RJ45 cable manipulated: The cable connecting the Slave DX to the air curtain is an 8-way crossover telephone cable. **If manipulated (connector cut or removed) and spliced the wrong way round, the air curtain will not work properly** and may also damage the electronics. Simply re-splicing the connector correctly will solve the problem (check the connection diagram).

B) Incorrect telephone cable connection: The Slave DX must be connected to the “control” connector of the air curtain. If we connect slave air curtains we must connect and RJ45 cable from the “auxiliar” connector of the first air curtain to the “control” of the the second air curtain and so on.

C) Incorrect power supply. The power supply to the air curtain depends on the type of power available and the type of heating of the unit. Connect according to the wiring diagram.

Most commons problems and solutions		
Symptom	Problem	Solution
No LED lights up on the Slave DX.	¿Is the RJ45 telephone cable original, without joints or shortening?	Change the cable or reconnect it correctly.
	¿Does power supply reach the air curtain?	Check the power supply of the air curtain. Between L and N must be 230V.
	Check the fuse.	The fuse of the curtain’s electronic plate must be OK.
	No part of the curtain electronic plate should be damaged.	Check especially the area near the transformer.
Slave DX control indicates speed, but the curtain does not work.	¿The RJ45 cable between the Slave DX and the connector “control” of the curtain is original?	<ul style="list-style-type: none"> •The RJ45 cable is in bad state or has been tailor-made incorrectly. Check. • If it runs in parallel with power cables, it must be shielded. • It’s not inserted well in the female connector. • Has been damaged. • The cable has more than 10mts of length and it’s not braided and shielded. • The shield of the RJ45 cable has not been connected to earth.
	RJ45 wrong connected.	The cable is inserted in the connector “auxiliar” of the curtain instead in the connector “control”. Inside of the connector “control” must not have little objects (bits of cable, remains of work, etc.) because they avoid the connector from entering completely. The connector is not well inserted.

Most commons problems and solutions

Symptom	Problem	Solution
The heat pump does not work.	Mitsubishi's screen does not turn on.	Check the supply of the DX kit. Check the cable between the kit and the screen.
	The screen turns on, but the hot air (or cold air if configured) does not work.	The interior temperature is high (or too low, in cooling mode).
	There's an error message on the Mitsubishi's screen.	Consult Mitsubishi's manual.
	The condenser does not start.	Check the tension of the outdoor unit. Check the cable of the kit to the outdoor unit. The curtain should have tension. Check the fuse of the curtain. Go to the question if telephone cable is original.
The heat pump is working, but the performance is abnormally low.	In heating mode, the outlet temperature of the unit's refrigerant is of 85-100°C, but it reaches the curtain at a very low temperature.	The refrigerant tube is clogged, chamfered or lacks thermal insulation. A clean sweep must be made. It must be visually checked that there are no dents and the condition of the insulator.
	Some sensor is not placed on its right place or its thermal insulation is wrong fixed or inexistent.	Check the installation and the insulation of the temperature sensors.
	The air curtain is at more meters than allowed from the outdoor unit or no extra gas charge has been added.	Consult Mitsubishi's manual.
	The height or maximum distance of the outdoor unit from the indoor one has been exceeded.	The maximum height between units must not exceed that stipulated by Mitsubishi for your unit. The linear distance must not exceed the meters stipulated by Mitsubishi. One possible solution is to change the unit for a Mitsubishi VRF. Consult.
	The refrigerant circuit may leak.	Check.
	The external machine has a malfunction.	Consult the troubleshooting of the outdoor unit on the Mitsubishi's manual.
	In VRF, the power of the outdoor units has been exceeded (simultaneity).	Turn off some indoor units or install more outdoor units.

ACCESSORIES



Clever Control

Intelligent proactive regulation, advanced functions, automatic/manual working, door delay, timer, save energy program, multi equipment management, BMS Modbus connection, etc.



Condensate pump

Allows to drain the condensed water from the curtain when working in cool mode.

Supports, feet, vibration dampers, etc. depending on the model.

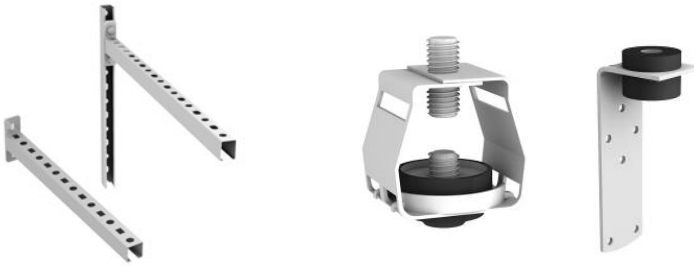

Door contact

RJ45 Cable 20m and 50m

Plenum and/or inlet/outlet kit (depending on the model)

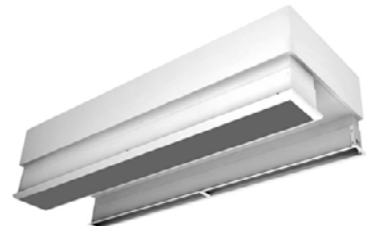

DECLARATION OF CONFORMITY



Declaration of conformity / Declaración de conformidad

Manufacturer **Motors i Ventiladors S.L. (AIRTECNICS)**
Fabricante **Conca de Barberà 6, Pol. Ind. Pla de la Bruguera**
08211 Castellar del Vallès (Barcelona) Spain

We declare, under our sole responsibility, that the product(s)
Declaramos, bajo nuestra única responsabilidad, que el/los producto(s)

Air Curtains
Cortinas de aire

with models
con los modelos

Air curtains DX / Cortinas de aire DX

is/are developed, designed and manufactured in accordance with the following directive(s)
ha(n) sido desarrollado(s), diseñado(s) y fabricado(s) de acuerdo con la(s) siguiente(s) directiva(s)

Low Voltage Directive 2014/35/UE
Directiva Baja Tensión 2014/35/UE

Electromagnetic Compatibility Directive 2014/30/UE
Directiva Compatibilidad Electromagnética 2014/30/UE

Restriction Certain Hazardous Substances Directive 2011/65/EU (RoHS)
Directiva Restricción Substancias Peligrosas 2011/65/EU

Eco-design Energy-related Products Directive 2009/125/EC
Directiva Diseño Ecológico Productos Con Energía 2009/125/CE

Remark: *The installer is responsible for making the whole heating system comply with the PED directive.*

Mención: *El instalador es el responsable de hacer que todo el sistema de calefacción cumpla con la directiva PED.*

applying the following harmonized standards in particular
aplicando las siguientes normas armonizadas en particular

LVD: EN 60335-1:2012 + AC:2014 + A11:2014 + A13:2017 + A14:2019 +
A2:2019 + A15:2019
EN 60335-2-30:2009 + A11:2012 + A1:2020 + A12:2020

EMC: EN 61000-3-11:2019
EN 61000-3-12:2011
EN 55014-1:2017 + A11:2020
EN 55014-2:2021

RoHS: EN 50581:2012

Date / Fecha
Name / Nombre
Position / Cargo

14/01/2022
Jordi Hierro
Technical Manager

AIRTECNICS EXPORT, S.L.
C/Conca de Barberà, 5 - Pla Bruguera
08211 CASTELLAR DEL VALLÈS
Tel. +34 93 714 36 36
CIF: ESB66276171

IDENTIFICATOR



Model <small>Modelo</small>	WINDBOX M 2000 P86		
Airflow <small>Caudal</small>	3320	m3/h	
Blowers <small>Ventiladores</small>	3,8 A	0,856 kW	230 V/50Hz
Heating <small>Calefacción</small>	Temperature <small>Temperatura</small>	Capacity <small>Capacidad</small>	Water Flow <small>Caudal Agua</small>
Water Coil <small>Bateria Agua</small>	80/60 °C	20,65 kW	900 l/h
Electric Heater <small>Bateria Eléctrica</small>	kW		
Serial Number <small>Número de Serie</small>	2022 01 21 / 113.864		

Each air curtain is identified by a unique serial number printed in a label located inside the door service. There is also indicated the model and their technical characteristics (flow, fans technical characteristics and power heating).

It is indispensable to have this number to facilitate possible replacements or technical information of the air curtain in question.



WINDBOX M 2000 P86 www.airtecnics.com

GUARANTEE

Your air curtain is guaranteed for a period of two years from the date of purchase. We will adjust, repair or replace at our discretion from our warehouse any defect, system failure or part found to be defective. The assembly cost out of our warehouse is at buyer expense. The products that, in our eyes, have been inadequately used, incorrectly manipulated, improperly installed, connected to different nominal tensions, modified, repaired by non-authorized workers or that have suffered damages during transport are totally excluded from the guarantee.

To validate the guarantee it should be correctly filled and enclosed with the invoice that vouches for the buying date. If it is manipulated, it will lose all validity.

It is the buyer's responsibility to take the necessary safety measures because in case of a failure or mistake in one of our products, no damages to third parties, sets or installations will occur.

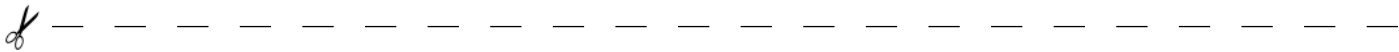

Guarantee draft

Air curtains data:

Model: Series number:

Invoice date:..... Invoice number:

Buyer data:

Name:

Address:

Country: Phone: Mail:.....

Seller data:

Name:

Address:

Country: Phone: Mail:.....

Buyer signature and stamp

Seller signature and stamp

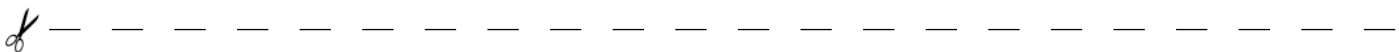

If you detect some error in this manual, we'll be pleased to receive your feedback, it helps us to improve even more. Airtècnics reserves the right to modify some of the specifications in this manual

Conca de Barberà, 6 - Pol. Ind. Pla de la Bruguera
E-08211 Castellar del Vallès (Barcelona) Spain
☎ + 34 93 715 99 88
airtecnicos@airtecnicos.com

www.airtecnicos.com