



Characteristics

Recessed Windbox air curtain specially conceived and designed for installation in false ceilings. It has a double function of disinfecting and purifying the air and surfaces, using Kleenfan and OH technologies which, thanks to the effect of photocatalysis and the generation of OH· hydroxyl radicals, eliminate viruses, bacteria, odours and contaminating gases, improving the quality of the air.



- Combines a double patented purification technology through the generation of hydroxyl radicals OH· and the effect of photocatalysis.
- Innovative OH active technology with efficient production of hydroxyl radicals, complies with the exposure limits against chemical agents adopted by the National Institute of Safety and Health (INSS), which purifies both air and surfaces through a chain reaction. Through Advanced Oxidation Processes (AOP) inactivates up to 99.9% of pathogenic microorganisms (viruses and bacteria), improves air quality (reducing volatile organic compounds and suspended particles) and eliminates odours.
- Includes one purificant cartridge with hydrogen peroxide solution to generate hydroxyl radicals.
- Kleenfan technology with photocatalytic purificant action fans. UV-A rays, from the long-life led, act on the titanium dioxide of the turbine generation Reactive Oxygen Species (ROS) than, through oxidation /reduction reactions, inactivate wide range of pathogenic microorganisms (viruses and bacteria). It mineralizes most of the pollutants present in urban areas produced by vehicles and industry (NOx, SOx, COx, formaldehydes, VOCs, etc.).
- Includes Advanced Clever Control with purification program operation 24h/day, 4 levels of air quality indicator and replacement alarm of hydrogen peroxide purificant cartridge (around 3 months duration, depending on conditions). Plug&Play, programmable, Intelligent, automatic, energy saving mode, Modbus RTU by PLC...
- Self-supporting casing construction made of galvanized steel plate, ready to be installed recessed in a false ceiling.
- Inlet grille (free of maintenance) made with aluminium profiles and blow-out nozzle, integrated in a single white frame colour RAL 9016. Other colours are available on request.
- Anodized aluminium outlet vanes, airfoil shaped, adjustable in both directions.
- EC Double-inlet centrifugal fans driven by an external rotor motor and low noise level, with very low consumption efficiency fans.
- "P" type with water heated coil. "E" type with electrical shielded elements, three stages with integrated regulation. "A" type without heating, air only. Optional expansion DX coil.

Specifications

50Hz

Unheated		
Model	Nominal Airflow (m³/h)	Recommended Installation Range (m)
RECM 1000 A OH+FC	1840	2,5-3,8
RECM 1500 A OH+FC	2760	2,5-3,8
RECM 2000 A OH+FC	3680	2,5-3,8
RECM 2500 A OH+FC	4600	2,5-3,8
RECG 1000 A OH+FC	2700	3-4,2
RECG 1500 A OH+FC	3600	3-4,2
RECG 2000 A OH+FC	5400	3-4,2
RECG 2500 A OH+FC	6300	3-4,2

Electrical Heating			
Model	Nominal Airflow (m³/h)	Electrical Heating Capacity 400Vx3 (kW)	Recommended Installation Range (m)
RECM 1000 E OH+FC	1840	3/6/9	2,5-3,8



Electrical Heating			
Model	Nominal Airflow (m³/h)	Electrical Heating Capacity 400Vx3 (kW)	Recommended Installation Range (m)
RECM 1500 E OH+FC	2760	4/8/12	2,5-3,8
RECM 2000 E OH+FC	3680	6/12/18	2,5-3,8
RECM 2500 E OH+FC	4600	6/12/18	2,5-3,8
RECG 1000 E OH+FC	2700	5/10/15	3-4,2
RECG 1500 E OH+FC	3600	7,5/15/22,5	3-4,2
RECG 2000 E OH+FC	5400	10/20/30	3-4,2
RECG 2500 E OH+FC	6300	10/20/30	3-4,2

Water Heating					
Model	Nominal Airflow (m³/h)	Recommended Installation Range (m)	Heating Capacity 80/60°C (kW)	Heating Capacity 60/40°C (kW)	Heating Capacity 50/40°C (kW)
RECM 1000 P86 OH+FC	1720	2,5-3,8	9.38	-	-
RECM 1500 P86 OH+FC	2580	2,5-3,8	14.58	-	-
RECM 2000 P86 OH+FC	3440	2,5-3,8	21.12	-	-
RECM 2500 P86 OH+FC	4300	2,5-3,8	27.53	-	-
RECG 1000 P86 OH+FC	2550	3-4,2	11.89	-	-
RECG 1500 P86 OH+FC	3400	3-4,2	17.29	-	-
RECG 2000 P86 OH+FC	5100	3-4,2	26.86	-	-
RECG 2500 P86 OH+FC	5950	3-4,2	33.63	-	-
RECM 1000 P64 OH+FC	1720	2,5-3,8	-	8.77	-
RECM 1500 P64 OH+FC	2580	2,5-3,8	-	14.02	-
RECM 2000 P64 OH+FC	3440	2,5-3,8	-	18.7	-
RECM 2500 P64 OH+FC	4300	2,5-3,8	-	23.33	-
RECG 1000 P64 OH+FC	2550	3-4,2	-	11.27	-
RECG 1500 P64 OH+FC	3400	3-4,2	-	16.77	-
RECG 2000 P64 OH+FC	5100	3-4,2	-	24.14	-
RECG 2500 P64 OH+FC	5950	3-4,2	-	28.84	-
RECM 1000 P54 OH+FC	1720	2,5-3,8	-	-	8.74
RECM 1500 P54 OH+FC	2580	2,5-3,8	-	-	14.71
RECM 2000 P54 OH+FC	3440	2,5-3,8	-	-	19.13
RECM 2500 P54 OH+FC	4300	2,5-3,8	-	-	24.95
RECG 1000 P54 OH+FC	2550	3-4,2	-	-	11.5
RECG 1500 P54 OH+FC	3400	3-4,2	-	-	17.86
RECG 2000 P54 OH+FC	5100	3-4,2	-	-	25.24
RECG 2500 P54 OH+FC	5950	3-4,2	-	-	31.38

60Hz

Unheated		
Model	Nominal Airflow (m³/h)	Recommended Installation Range (m)
RECM 1000 A OH+FC	1840	2,5-3,8
RECM 1500 A OH+FC	2760	2,5-3,8
RECM 2000 A OH+FC	3680	2,5-3,8
RECM 2500 A OH+FC	4600	2,5-3,8
RECG 1000 A OH+FC	2700	3-4,2
RECG 1500 A OH+FC	3600	3-4,2
RECG 2000 A OH+FC	5400	3-4,2
RECG 2500 A OH+FC	6300	3-4,2



Electrical Heating			
Model	Nominal Airflow (m³/h)	Electrical Heating Capacity 400Vx3 (kW)	Recommended Installation Range (m)
RECM 1000 E OH+FC	1840	3/6/9	2,5-3,8
RECM 1500 E OH+FC	2760	4/8/12	2,5-3,8
RECM 2000 E OH+FC	3680	6/12/18	2,5-3,8
RECM 2500 E OH+FC	4600	6/12/18	2,5-3,8
RECG 1000 E OH+FC	2700	5/10/15	3-4,2
RECG 1500 E OH+FC	3600	7,5/15/22,5	3-4,2
RECG 2000 E OH+FC	5400	10/20/30	3-4,2
RECG 2500 E OH+FC	6300	10/20/30	3-4,2

Water Heating					
Model	Nominal Airflow (m³/h)	Recommended Installation Range (m)	Heating Capacity 80/60°C (kW)	Heating Capacity 60/40°C (kW)	Heating Capacity 50/40°C (kW)
RECM 1000 P86 OH+FC	1720	2,5-3,8	9.38	-	-
RECM 1500 P86 OH+FC	2580	2,5-3,8	14.58	-	-
RECM 2000 P86 OH+FC	3440	2,5-3,8	21.12	-	-
RECM 2500 P86 OH+FC	4300	2,5-3,8	27.53	-	-
RECG 1000 P86 OH+FC	2550	3-4,2	11.89	-	-
RECG 1500 P86 OH+FC	3400	3-4,2	17.29	-	-
RECG 2000 P86 OH+FC	5100	3-4,2	26.86	-	-
RECG 2500 P86 OH+FC	5950	3-4,2	33.63	-	-
RECM 1000 P64 OH+FC	1720	2,5-3,8	-	8.77	-
RECM 1500 P64 OH+FC	2580	2,5-3,8	-	14.02	-
RECM 2000 P64 OH+FC	3440	2,5-3,8	-	18.7	-
RECM 2500 P64 OH+FC	4300	2,5-3,8	-	23.33	-
RECG 1000 P64 OH+FC	2550	3-4,2	-	11.27	-
RECG 1500 P64 OH+FC	3400	3-4,2	-	16.77	-
RECG 2000 P64 OH+FC	5100	3-4,2	-	24.14	-
RECG 2500 P64 OH+FC	5950	3-4,2	-	28.84	-
RECM 1000 P54 OH+FC	1720	2,5-3,8	-	-	8.74
RECM 1500 P54 OH+FC	2580	2,5-3,8	-	-	14.71
RECM 2000 P54 OH+FC	3440	2,5-3,8	-	-	19.13
RECM 2500 P54 OH+FC	4300	2,5-3,8	-	-	24.95
RECG 1000 P54 OH+FC	2550	3-4,2	-	-	11.5
RECG 1500 P54 OH+FC	3400	3-4,2	-	-	17.86
RECG 2000 P54 OH+FC	5100	3-4,2	-	-	25.24
RECG 2500 P54 OH+FC	5950	3-4,2	-	-	31.38



Dimensions

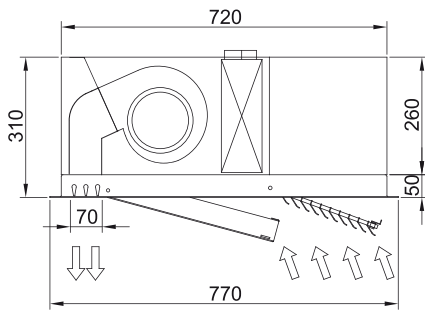
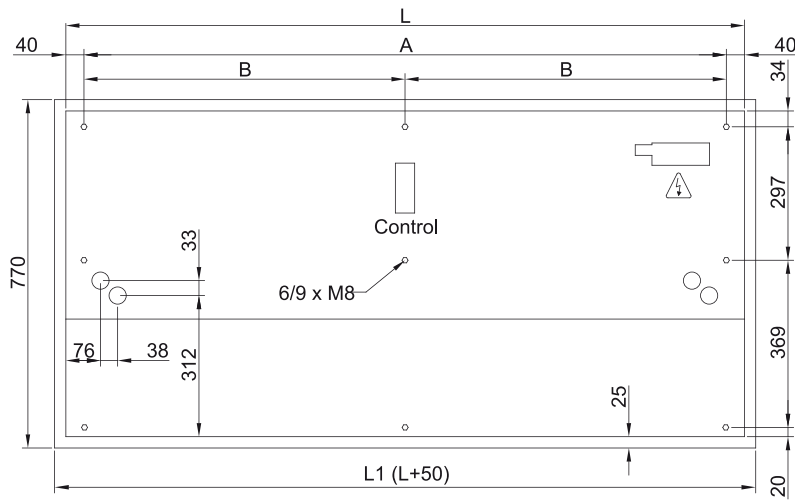

	L	L1	A	B
Recessed Windbox 1000	1000	1050	920	-
Recessed Windbox 1500	1500	1550	1420	710
Recessed Windbox 2000	2000	2050	1920	960
Recessed Windbox 2500	2500	2550	2420	1210