



Characteristics

RECESSED WINDBOX is a high pressure compact and robust air curtain from our standard range with a timeless and visually pleasing design. It is specially designed for recessed installation in false ceilings. It is a suitable air curtain for all types of commercial entrances.

Its energy saving heat pump compatible version achieves a reduction of up to 70% in consumption and CO2 emissions (in heating mode).

Includes only heating direct expansion coil with installed temperature sensors. Under request it can be modified to work in cooling and heating mode (not recommended) with optional condensate water pump. Internal prefilter included.

Advanced Plug&Play control. Includes: Advanced PRO control with LCD display and integrated thermostat, door contact, 7m RJ11 cable and remote control.

DX VRF
Ready to connect to SAMSUNG CAC outdoor heat pump unit (R410A). Requires SAMSUNG DX Interface KIT adapted for air curtain and programmable control.



- Energy saving heat pump air curtain: Up to 70% reduction in costs and CO2 emissions (heating mode).
- Self-supporting casing construction made of galvanized steel plate, ready to be installed recessed in a false ceiling.
- Inlet grille (free of maintenance) made with aluminium profiles and blow-out nozzle, integrated in a single white frame colour RAL 9016. Other colours are available on request. Internal prefilter included.
- Anodized aluminium outlet vanes, airfoil shaped, adjustable in both directions.
- Low noise double-inlet centrifugal fans with external rotor motor. 5-speed controller. EC models assembled with very low consumption efficiency fans.
- Includes only heating direct expansion coil with installed temperature sensors. Under request it can be modified to work in cooling and heating mode (not recommended) with optional condensate water pump.
- Advanced Plug&Play control. Includes: Advanced PRO control with integrated LCD screen, door contact, 7m RJ11 cable and remote control. With integrated functions: door delay (configurable); operation, alarm and maintenance warning signals; and multiple digital inputs that modify the curtain's operation.
- Includes protective varnish for the electronic board and control.
- DX VRF:
Ready to connect to SAMSUNG CAC outdoor heat pump unit (R410A). Requires SAMSUNG DX Interface KIT adapted for air curtain and programmable control, please consult.

Specifications

50Hz



Dimensions

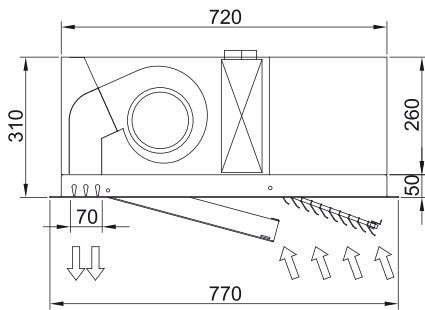
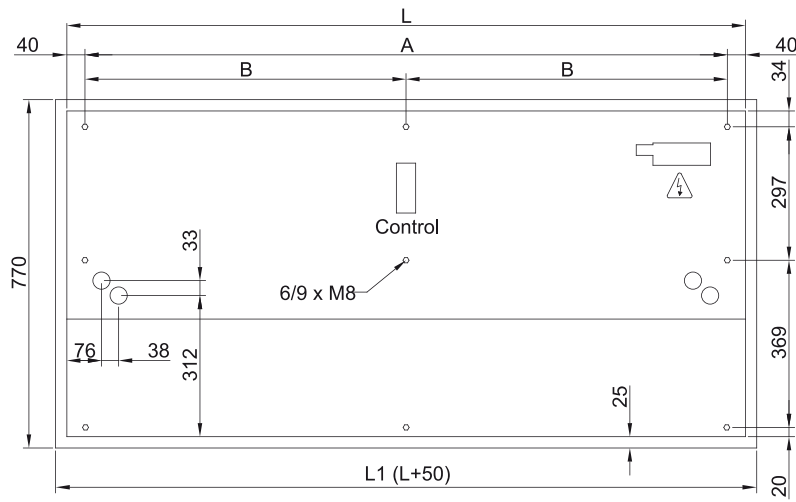

	L	L1	A	B
Recessed Windbox 1000	1000	1050	920	-
Recessed Windbox 1500	1500	1550	1420	710
Recessed Windbox 2000	2000	2050	1920	960
Recessed Windbox 2500	2500	2550	2420	1210