



Characteristics

WINDBOX air curtains range provide equipment suitable for all types of commercial entrances. A compact and robust galvanised steel air curtain from our standard range with a timeless design, ready for visible installation over the door and prepared for multiple false ceiling installation configurations.

Its energy saving heat pump compatible version achieves a reduction of up to 70% in consumption and CO2 emissions (in heating mode).

Includes only heating direct expansion coil with installed temperature sensors. Under request it can be modified to work in cooling and heating mode (not recommended) with optional condensate water pump. Internal prefilter included.

Advanced Plug&Play control. Includes: Advanced PRO control with LCD display and integrated thermostat, door contact, 7m RJ11 cable and remote control.

DX VRF
 Ready to connect to SAMSUNG CAC outdoor heat pump unit (R410A). Requires SAMSUNG DX Interface KIT adapted for air curtain and programmable control.

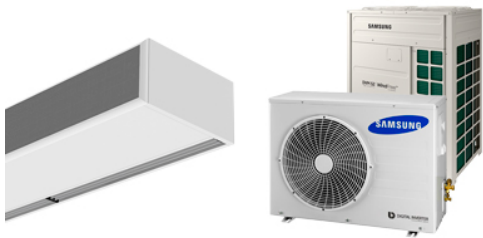

- Energy saving heat pump air curtain: Up to 70% reduction in costs and CO2 emissions (heating mode).
- Self-supporting casing construction made of galvanized steel plate, finished in structural epoxy-polyester painting white colour RAL9016 as standard. Other colours or stainless steel are available on request.
- Micro-perforated inlet grille with filter functions and easy service. Internal prefilter included.
- Anodized aluminium outlet vanes, airfoil shaped, adjustable from 0 to 15° each side.
- Low noise double-inlet centrifugal fans with external rotor motor. 5-speed controller. EC models assembled with very low consumption efficiency fans.
- Includes only heating direct expansion coil with installed temperature sensors. Under request it can be modified to work in cooling and heating mode (not recommended) with optional condensate water pump.
- Advanced Plug&Play control. Includes: Advanced PRO control with integrated LCD screen, door contact, 7m RJ11 cable and remote control. With integrated functions: door delay (configurable); operation, alarm and maintenance warning signals; and multiple digital inputs that modify the curtain's operation.
- Includes protective varnish for the electronic board and control.
- DX VRF:
 Ready to connect to SAMSUNG CAC outdoor heat pump unit (R410A). Requires SAMSUNG DX Interface KIT adapted for air curtain and programmable control, please consult.

Specifications

50Hz

60Hz

Dimensions

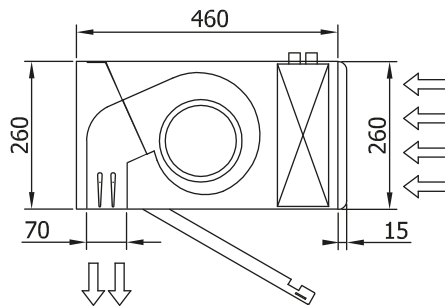
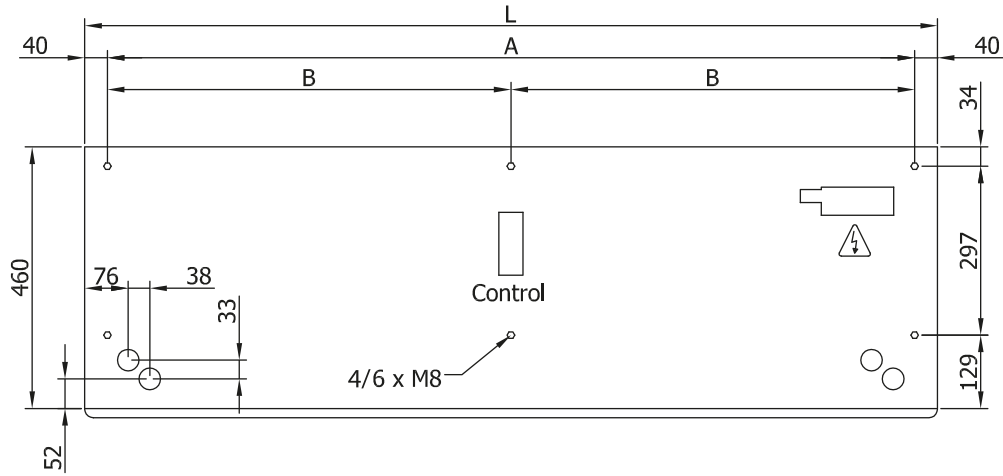

L	A	B
1000	920	-
1500	1420	710
2000	1920	960
2500	2420	1210
3000	2920	1460